

TM 9-2320-312-10

TECHNICAL MANUAL

OPERATOR'S MANUAL

FOR

TRUCK, TRACTOR, YARD TYPE:
46,662 GVWR, DED, 4 X 2, M878A2
(NSN 2320-01-452-5579)



Approved for public release; distribution is unlimited.

HEADQUARTERS, DEPARTMENT OF THE ARMY

DECEMBER 2003

WARNING SUMMARY

This warning summary contains general safety warnings and hazardous materials warnings that must be understood and applied during operation and maintenance of this equipment. Failure to observe these precautions could result in serious injury or death to personnel. Also included are explanations of safety and hazardous materials icons used within the technical manual.



BIOLOGICAL - abstract symbol bug shows that a material may contain bacteria or viruses that present a danger to life or health.



CHEMICAL - drops of liquid on hand shows that the material will cause burns or irritation to human skin or tissue.



EAR PROTECTION - Headphones over ears show that noise level will harm ears.



ELECTRICAL - electrical wire to arm with electricity symbol running through human body shows that shock hazard is present.



EYE PROTECTION - person with goggles shows that the material will injure the eyes.



FIRE - flame shows that a material may ignite and cause burns.

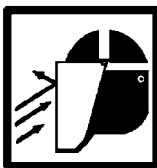

FLYING PARTICLES - arrows bouncing off face with face shield shows that particles flying through the air will harm face.



HEAVY OBJECT - human figure stooping over heavy object shows physical injury potential from improper lifting technique.



HEAVY PARTS - hand with heavy object on top shows that heavy parts can crush and harm.



HEAVY PARTS - heavy object on human figure shows that heavy parts present a danger to life or limb.



HOT AREA - hand over object radiating heat shows that part is hot and can burn.



RADIOACTIVE - identifies a material that emits radioactive energy and can injure human tissue or organs.



VAPOR - human figure in a cloud shows that material vapors present a danger to life or health.

FOR INFORMATION ON FIRST AID, REFER TO FM 4-25.11.



WARNING

CARBON MONOXIDE (EXHAUST GASES) CAN KILL!

- Carbon monoxide is a colorless, odorless, deadly poison which, when breathed, deprives the body of oxygen and causes suffocation. Exposure to air containing carbon monoxide produces symptoms of headache, dizziness, loss of muscular control, apparent drowsiness, and coma. Permanent brain damage or death can result from severe exposure.
 - Carbon monoxide occurs in exhaust fumes of internal combustion engines. Carbon monoxide can become dangerously concentrated under conditions of inadequate ventilation. The following precautions must be observed to ensure safety of personnel when engine of tractor is operated.
1. DO NOT operate tractor engine in enclosed areas without adequate ventilation.
 2. DO NOT idle tractor engine without adequate ventilation.
 3. DO NOT drive tractor with inspection plates or cover plates removed.
 4. BE ALERT for exhaust poisoning symptoms. They are:
 - Headache
 - Dizziness
 - Sleepiness
 - Loss of muscular control
 5. If you see another person with exhaust poisoning symptoms:
 - Remove person from area.
 - Expose to fresh air.
 - Keep person warm.
 - Do not permit physical exercise.
 - Administer cardiopulmonary resuscitation (CPR), if necessary.
 - Notify a medic.
 6. BE AWARE. The field protective mask for nuclear-biological-chemical (NBC) protection will not protect you from carbon monoxide poisoning.

The Best Defense Against Carbon Monoxide Poisoning Is Good Ventilation!



WARNING

BATTERIES



- To avoid injury, eye protection and acid-resistant gloves must be worn when working around batteries. Do not smoke, use open flame, make sparks or create other ignition sources around batteries. If a battery is giving off gases, it can explode and cause injury to personnel. Remove all jewelry such as rings, ID tags, watches, and bracelets. If jewelry or a tool contacts a battery terminal, a direct short will result in instant heating or electric shock, damage to equipment, and injury to personnel.
 - Sulfuric acid contained in batteries can cause serious burns. If battery corrosion or electrolyte makes contact with skin, eyes or clothing, take immediate action to stop the corrosive burning effects. Failure to follow these procedures may result in death or serious injury to personnel.
- a. **Eyes.** Flush with cold water for no less than 15 minutes and seek medical attention immediately.
 - b. **Skin.** Flush with large amounts of cold water until all acid is removed. Seek medical attention as required.
 - c. **Internal.** If corrosion or electrolyte is ingested, drink large amounts of water or milk. Follow with milk of magnesia, beaten egg or vegetable oil. Seek medical attention immediately.
 - d. **Clothing/Equipment.** Wash area with large amounts of cold water. Neutralize acid with baking soda or household ammonia.

WARNING

BRAKES

- When caging brakes, block wheels to keep tractor from moving when brakes are released. Failure to follow this warning may result in death or injury to personnel or damage to equipment.
- Brake chamber contains spring under great pressure. To prevent personnel injury, avoid working directly behind chamber. If caging bolt will not engage properly, spring may be broken.
- DO NOT remove clamp ring around spring brake chamber. It is under tension and can cause personnel injury if released.
- When spring brakes are actuated due to loss of air pressure, vehicle will stop quickly which could result in injury to personnel. Also, vehicle cannot be driven again until malfunction is repaired and enough air supply is present for operation of service brakes.



WARNING

CAB TILT SYSTEM

- Ensure that no part of body is under cab while tilting. Stand clear of front and rear of cab while it is being raised. Ensure that tools and supplies are removed from cab and that cab doors are securely closed before tilting cab. Failure to do so may result in serious injury or death to personnel.
- Always check that cab tilt safety prop is properly engaged before working under cab. Cab could fall and cause serious injury or death.
- Ensure cab latch fully engages after lowering cab. If cab latch is not engaged, cab could tilt while vehicle is in motion. Failure to follow this warning may result in injury or death to personnel.



WARNING
CAPACITOR(S)



- To avoid injury, eye protection, protective clothing, and gloves must be worn when working around capacitors. Capacitors contain an electrolyte that is a potassium hydroxide solution. Potassium hydroxide is highly corrosive and can cause serious burns. If capacitor case becomes cracked, leaking electrolyte can result in fumes that are hazardous to inhale. If electrolyte makes contact with skin, eyes or clothing, take immediate action to stop the corrosive burning effects. Failure to follow these procedures may result in death or serious injury to personnel.
 - a. **Eyes.** Flush with plenty of water for at least 15 minutes, occasionally lifting upper and lower eyelids. Seek medical attention immediately.
 - b. **Skin.** Wash with soap and water for at least 15 minutes, while removing contaminated clothing and shoes. Dispose of contaminated clothing in a manner that limits further exposure. Seek medical attention immediately.
 - c. **Ingestion.** Do NOT induce vomiting. Drink 2-4 cups of milk or water. Seek medical attention immediately.
 - d. **Inhalation.** Remove from exposure to fresh air immediately. If not breathing, give CPR (cardio-pulmonary resuscitation). If breathing is difficult, administer oxygen. Seek medical attention immediately.
- Remove all jewelry such as rings, ID tags, watches, and bracelets, when working around capacitors. If jewelry or a tool contacts a capacitor terminal, a direct short may result, causing instant heating and electric shock at the point of short circuit. Damage to equipment and injury to personnel could result.

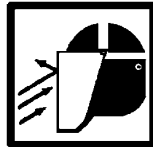

WARNING
COMPRESSED AIR

Compressed air used for cleaning purposes should never exceed 30 psi (207 kPa). Wear protective clothing (goggles/shield, gloves, etc.) and use caution to avoid injury to personnel.



WARNING
COOLANT HANDLING

Wear protective gloves when handling coolants. If exposed to coolant, promptly wash exposed skin and change coolant-soaked clothing. Failure to follow this warning may result in injury to personnel.



WARNING

DRY CLEANING SOLVENT



Dry cleaning solvent MIL-PRF-680 Type III is an environmentally compliant and low toxic material. However, it may be irritating to the eyes and skin. The use of protective gloves and goggles is suggested. Use in well-ventilated areas. Keep away from open flames and other sources of ignition.



WARNING



ETHER AUTOMATIC COLD START SYSTEM

Ether fuel is extremely flammable and toxic. DO NOT smoke and make sure you are in a well-ventilated area away from heat, open flames or sparks. Wear eye protection. Avoid contact with skin and eyes and avoid breathing ether fumes. If fluid enters or fumes irritate the eyes, wash immediately with large quantities of clean water for 15 minutes. Seek medical attention immediately if ether is inhaled or causes eye irritation. Failure to follow this warning may cause death or serious injury to personnel.



WARNING

FIRE EXTINGUISHER

Discharging large quantities of dry chemical fire extinguisher in cab may result in temporary breathing difficulty during and immediately after the discharge event. Discharge fire extinguisher from outside the cab. Ventilate cab thoroughly prior to reentry.



WARNING

FUEL HANDLING

- DO NOT smoke or permit any open flame in area of tractor while you are servicing fuel system. Be sure hose nozzle is grounded against filler tube during refueling to prevent static electricity. Failure to follow this warning may result in injury to personnel or equipment damage.
- DO NOT perform fuel system checks, inspections or maintenance while smoking or near fire, flames or sparks. Fuel may ignite, causing damage to vehicle and injury or death to personnel.
- Wear fuel-resistant gloves when handling fuels and promptly wash exposed skin and change fuel-soaked clothing.
- If equipped with arctic heater, be sure to turn heater off during refueling.



WARNING

HAZARDOUS WASTE DISPOSAL

When servicing this vehicle, performing maintenance, or disposing of materials such as engine coolant, transmission fluid, lubricants, battery acids or batteries, consult your unit/local hazardous waste disposal center or safety office for local regulatory guidance. If further information is needed, please contact The Army Environmental Hotline at 1-800-872-3845.



WARNING

HEARING PROTECTION

Hearing protection is required when operating this vehicle or when working in close proximity to vehicle when it is running. Failure to wear hearing protection may result in hearing loss.



WARNING

HYDRAULIC FLUID HANDLING

Wear protective gloves when handling hydraulic fluids. If exposed to hydraulic fluid, promptly wash exposed skin and change hydraulic fluid-soaked clothing. Failure to follow this warning may result in injury to personnel.



WARNING

LUBRICATING OIL HANDLING

Wear protective gloves when handling oils. If exposed to lubricating oil, promptly wash exposed skin and change oil-soaked clothing. Failure to follow this warning may result in injury to personnel.



WARNING
NBC EXPOSURE



- If NBC exposure is suspected, personnel wearing protective equipment must handle all air cleaner media. Consult your NBC Officer or NBC NCO for appropriate handling or disposal procedures.
- NBC contaminated filters must be handled using adequate precautions (FM 21-40) and must be disposed of by trained personnel.



To order this NBC decal use:

National Stock Number (NSN) - 7690-01-114-3702

Part Number (PN) - 12296626

Commercial and Government Entity Code (CAGEC) - 19207



WARNING
PRESSURIZED COOLING SYSTEM



- DO NOT service cooling system unless engine has cooled to at least 120°F (50°C) as indicated on coolant temperature gauge. This is a pressurized cooling system and escaping steam or hot coolant will cause serious burns.
- Wear effective eye, glove, and skin protection when handling coolants. Failure to do so may cause injury.

WARNING

RO/RO PROCEDURES

- Safe RO/RO operation depends on strict adherence to RO/RO regulations. Failure to do so may result in injury or death to personnel or damage to equipment.
- Use 1st gear ONLY and exercise extreme caution when driving up or down ramp. Operator must follow instructions from ground guides at all times. Proceed slowly and raise and lower fifth wheel as required so that trailer landing gear and under ride bar at rear of trailer do not contact ramp. Failure to follow this warning may result in an accident, causing damage to equipment or injury or death to personnel.
- If tractor and fully-loaded trailer combination is stopped while negotiating crest of ramp, then engine is accelerated to resume forward movement, front end of tractor may lift off ground. To prevent this, do NOT accelerate engine suddenly. Accelerate engine slowly. Failure to follow this warning may cause loss of vehicle control and injury or death to personnel.



WARNING
SLAVE STARTING

- When slave starting tractor, use NATO slave cable that DOES NOT have loose or missing insulation.
- DO NOT proceed if suitable cable is not available.
- DO NOT use civilian-type jumper cables.

WARNING
TIRE CHANGING

- Whenever wheel nuts require tightening or a wheel has been removed and replaced, wheel nuts must be tightened to the required torque. Failure to follow this warning may result in serious injury to personnel or damage to equipment.
- To avoid serious injury or death, NEVER attempt to inflate a tire that has been run flat or seriously under inflated. Notify Unit Maintenance to break down tire and wheel assembly for inspection.

WARNING
TOWING

Brakes will be released when air is applied to a disabled vehicle. DO NOT connect air lines to a disabled vehicle without first blocking wheels and connecting tow bar between vehicles. Failure to follow this warning could result in death or injury to personnel and damage to equipment.

WARNING
TRACTOR OPERATION

- This vehicle has been designed to operate safely and efficiently within the limits specified in this TM. Operation beyond these limits is prohibited in accordance with AR 70-1.
- The M878A2 Yard Tractor has a solid mount rear axle suspension and handles differently than a tractor with a sprung suspension. When operating without a trailer, this difference is even more noticeable. Operators must become familiar with the handling of the yard tractor, during training and initial operations, to avoid the potential hazard of vehicle instability and loss of control. Failure to do so may result in serious injury or death to personnel or damage to equipment.
- BE ALERT for personnel in the area while operating tractor. Always check to ensure area is clear of personnel and obstructions before moving. Failure to follow this warning may result in serious injury or death to personnel.
- The M878A2 Yard Tractor, without a trailer, is capable of making turns tighter than 90 degrees. When towing a trailer, attempting turns tighter than 90 degrees will cause interference between tractor and semitrailer. The point of interference is directly related to the position of the fifth wheel. The higher the fifth wheel, the more the turning radius is reduced. Failure to follow this warning could result in injury to personnel or damage to equipment.
- Use of seat belt while operating vehicle is mandatory. Fasten belt BEFORE driving. Trying to fasten belt while driving creates a hazardous condition. Failure to follow this warning may result in death or injury to personnel.
- DO NOT allow riders on the tractor. Failure to follow this warning may result in serious injury or death to personnel.

WARNING

TRACTOR OPERATION - CONTINUED

- Use caution when coupling or uncoupling from trailer. BE ALERT for personnel in area. Ensure that hands, arms, and body are clear of potential pinch points. Failure to follow this warning may result in injury or death to personnel.
- DO NOT exceed 15 mph (24 kph) when towing a trailer. Operating at speeds in excess of 15 mph (24 kph) may lead to loss of vehicle control, resulting in injury or death to personnel.
- Operating tractor with an underinflated or defective tire may lead to tire failure and loss of steering control. Injury to personnel or damage to equipment may result.
- If vehicle is left with engine running, vehicle can move suddenly causing serious injury or death to personnel or damage to equipment.
- Use extreme caution when raising or lowering fifth wheel, especially when tractor/trailer combination is moving. Raise or lower fifth wheel only enough to achieve adequate clearance for trailer's landing gear and under ride bar. Failure to follow this warning may cause vehicle to roll over, resulting in injury or death to personnel.
- Never tow a trailer above the minimum height required for landing gear to clear the ground. Lifting fifth wheel and trailer drastically increases the center of gravity of the trailer and increases the chance of a rollover. The higher the fifth wheel is raised, the slower the yard tractor should be driven.

WARNING

WORK SAFETY



- Use caution when lifting or handling wheel and tire assembly. It is heavy and could cause injury if improperly lifted or it falls on you.



- Hydraulic jack is intended only for lifting tractor, not for supporting vehicle to perform maintenance. DO NOT get under tractor after its raised unless it is properly supported with blocks or jack-stands. Failure to observe this warning may result in death or injury to personnel.
- Failure to completely turn ON or OFF air shutoff valves will cause loss of brakes on trailer or tractor.



- Lifting cables, chains, hooks, and slings used for lifting tractor must be in good condition and of suitable capacity. Failure to follow this warning may result in injury or death to personnel and damage to equipment.



- Improper use of lifting equipment and improper attachment of cables to vehicle can result in serious personnel injury and equipment damage. Observe all standard rules of safety.

OPERATOR'S MANUAL

FOR

**TRUCK, TRACTOR, YARD TYPE:
 46,662 GVWR, DED, 4 X 2, M878A2
 (NSN 2320-01-452-5579)**

TM 9-2320-312-10, dated 17 December 2003, is changed as follows:

1. File this change sheet in front of the publication for reference purposes.
2. New or changed material is indicated by a vertical bar adjacent to the material and/or by change designations at the bottom of the affected page.
3. Remove old pages and insert new pages as indicated below:

Remove Pages

c through j
A/(B Blank)
 0001 00-1 and 0001 00-2
 0002 00-1 and 0002 00-2
 0002 00-5 through 0002 00-10
 0003 00-1 through 0003 00-4
 0003 00-7 and 0003 00-8
 0004 00-3 through 0004 00-6
 0004 00-19 through 0004 00-22
 0005 00-1 through 0005 00-4
 0005 00-7 through 0005 00-10
 0005 00-15 and 0005 00-16
 0005 00-19 through 0005 00-24
 0006 00-5 and 0006 00-6
 0007 00-1 and 0007 00-2
 0007 00-11 and 0007 00-12
 0007 00-17 and 0007 00-18
 0007 00-21 and 0007 00-22
 0009 00-1 and 0009 00-2
 0010 00-3 and 0010 00-4
 0011 00-1 through 0011 00-5/(0011 00-6 Blank)

 0012 00-1 through 0012 00-6
 0012 00-17 and 0012 00-34
 0013 00-1 and 0013 00-2
 0014 00-1 and 0014 00-2
 0016 00-1 and 0016 00-2
 0017 00-1 through 0017 00-4
 0018 00-1 and 0018 00-2
 0019 00-1 and 0019 00-2

Insert Pages

c through j
A and B
 0001 00-1 and 0001 00-2
 0002 00-1 and 0002 00-2
 0002 00-5 through 0002 00-10
 0003 00-1 through 0003 00-4
 0003 00-7 and 0003 00-8
 0004 00-3 through 0004 00-6
 0004 00-19 through 0004 00-22
 0005 00-1 through 0005 00-4
 0005 00-7 through 0005 00-10
 0005 00-15 and 0005 00-16
 0005 00-19 through 0005 00-24
 0006 00-5 and 0006 00-6
 0007 00-1 and 0007 00-2
 0007 00-11 and 0007 00-12
 0007 00-17 and 0007 00-18
 0007 00-21 and 0007 00-22
 0009 00-1 and 0009 00-2
 0010 00-3 and 0010 00-4
 0011 00-1 through 0011 00-7/(0011
 00-8 Blank)
 0012 00-1 through 0012 00-6
 0012 00-17 and 0012 00-34
 0013 00-1 and 0013 00-2
 0014 00-1 and 0014 00-2
 0016 00-1 and 0016 00-2
 0017 00-1 through 0017 00-4
 0018 00-1 and 0018 00-2
 0019 00-1 and 0019 00-2

Approved for public release; distribution is unlimited.

By Order of the Secretary of the Army:

PETER J. SCHOOMAKER
General, United States Army
Chief of Staff

Official:



SANDRA R. RILEY

Administrative Assistant to the
Secretary of the Army

0510802

DISTRIBUTION: To be distributed in accordance with the initial distribution requirements for IDN: 381128, requirements for TM 9-2320-312-10.

LIST OF EFFECTIVE PAGES/WORK PACKAGES

Dates of issue for original manual and change pages are:

Original 17 December 2003
 Change 1 2 September 2005

TOTAL NUMBER OF PAGES FOR FRONT AND REAR MATTER IS 34 AND TOTAL NUMBER OF WORK PACKAGES IS 19 CONSISTING OF THE FOLLOWING:

Page/WP No.	*Change No.
Cover/(Back Blank)	0
a and b	0
c through h	1
i	0
j	1
A and B	1
i through iv	0
0001 00-1 and 0001 00-2	1
0002 00-1	1
0002 00-2 through 0002 00-4	0
0002 00-5 and 0002 00-6	0
0002 00-7 through 0002 00-10	1
0003 00-1 through 0003 00-3	1
0003 00-4 through 0003 00-7	0
0003 00-8	1
0003 00-9/(0003 00-10 Blank)	0
0004 00-1 through 0004 00-3	0
0004 00-4 and 0004 00-5	1
0004 00-6 through 0004 00-18	0
0004 00-19	1
0004 00-20 and 0004 00-21	0
0004 00-22	1
0004 00-23/(0004 00-24 Blank)	0
0005 00-1	0
0005 00-2 and 0005 00-3	1
0005 00-4 through 0005 00-7	0
0005 00-8 through 0005 00-10	1
0005 00-11 through 0005 00-15	0
0005 00-16	1
0005 00-17 and 0005 00-18	0
0005 00-19 through 0005 00-22	1
0005 00-23	0
0005 00-24	1
0005 00-25/(0005 00-26 Blank)	0
0006 00-1 through 0006 00-5	0
0006 00-6	1
0006 00-7 through 0006 00-11/(0006 00-12 Blank)	0
0007 00-1 and 0007 00-2	1
0007 00-3 through 0007 00-10	0
0007 00-11 and 0007 00-12	1

TM 9-2320-312-10

0007 00-13 through 0007 00-17	0
0007 00-18	1
0007 00-19 and 0007 00-20	0
0007 00-21	1
0007 00-22	0
0008 00-1/(0008 00-2 Blank)	0
0009 00-1	1
0009 00-2	0
0010 00-1 and 0010 00-2	0
0010 00-3	1
0010 00-4 through 0010 00-7/(0010 00-8 Blank)	0
0011 00-1	1
0011 00-2	0
0011 00-3 through 0011 00-7/(0011 00-8 Blank)	1
0012 00-1 and 0012 00-2	1
0012 00-3	0
0012 00-4 and 0012 00-5	1
0012 00-6 through 0012 00-16	0
0012 00-17	1
0012 00-18 and 0012 00-19	0
0012 00-20 and 0012 00-21	1
0012 00-22 and 0012 00-23	0
0012 00-24 through 0012 00-33	1
0012 00-34	0
0013 00-1	1
0013 00-2 through 0013 00-3/(0013 00-4 Blank)	0
0014 00-1	1
0014 00-2 through 0014 00-6	0
0015 00-1 through 0015 00-3/(0015 00-4 Blank)	0
0016 00-1	1
0016 00-2	0
0017 00-1	0
0017 00-2 through 0017 00-4	1
0018 00-1	0
0018 00-2	1
0019 00-1	0
0019 00-2	1
0019 00-3/(0019 00-4 Blank)	0
Index-1 through Index-5/(Index-6 Blank)	0
Authentication Page	0
DA Form 2028	0
Back Cover	0

* Zero in this column indicates an original page or work package.

OPERATOR'S MANUAL

FOR

TRUCK, TRACTOR, YARD TYPE:
46,662 GVWR, DED, 4 X 2, M878A2
(NSN 2320-01-452-5579)

REPORTING ERRORS AND RECOMMENDING IMPROVEMENTS

You can help improve this publication. If you find any mistakes or if you know of a way to improve the procedures, please let us know. Submit your DA Form 2028 (*Recommended Changes to Equipment Technical Publications*), through the Internet, on the Army Electronic Product Support (AEPS) website. The Internet address is <http://aeprs.ria.army.mil>. If you need a password, scroll down and click on "ACCESS REQUEST FORM". The DA Form 2028 is located in the ONLINE FORMS PROCESSING section of the AEPS. Fill out the form and click on SUBMIT. Using this form on the AEPS will enable us to respond quicker to your comments and better manage the DA Form 2028 program. You may also mail, fax or e-mail your letter, DA Form 2028 direct to: AMSTA-LC-CI/TECH PUBS, TACOM-RI, 1 Rock Island Arsenal, Rock Island, IL 61299-7630. The e-mail address is: TACOM-TECH-PUBS@ria.army.mil. The fax number is DSN 793-0726 or Commercial (309) 782-0726.

DISTRIBUTION STATEMENT A - Approved for public release; distribution is unlimited.

Table of Contents

	Page Number
Warning Summary	a
How to Use This Manual	iii
CHAPTER 1 INTRODUCTORY INFORMATION WITH THEORY OF OPERATION	
WP 0001 00 General Information	0001 00-1
WP 0002 00 Equipment Description and Data.	0002 00-1
WP 0003 00 Theory Of Operation	0003 00-1
CHAPTER 2 OPERATING INSTRUCTIONS	
WP 0004 00 Description and Use Of Operator's Controls and Indicators.	0004 00-1
WP 0005 00 Operation Under Usual Conditions	0005 00-1
WP 0006 00 Operation Under Unusual Conditions	0006 00-1
WP 0007 00 Stowage and Decal, Data Plate, and Stencil Guide	0007 00-1
CHAPTER 3 OPERATOR TROUBLESHOOTING	
WP 0008 00 Troubleshooting Instructions	0008 00-1
WP 0009 00 Troubleshooting Symptom Index	0009 00-1
WP 0010 00 Troubleshooting Procedures	0010 00-1

Table of Contents - Continued

**Page
Number**

CHAPTER 4 OPERATOR MAINTENANCE INSTRUCTIONS

WP 0011 00	Preventive Maintenance Checks and Services (PMCS) Introduction	0011 00-1
WP 0012 00	Preventive Maintenance Checks and Services (PMCS)	0012 00-1
WP 0013 00	Refueling and Fuel System Priming	0013 00-1
WP 0014 00	Wheel and Tire Assembly Replacement	0014 00-1
WP 0015 00	Engine Air Cleaner Service	0015 00-1

CHAPTER 5 SUPPORTING INFORMATION

WP 0016 00	References	0016 00-1
WP 0017 00	Components of End Item (COEI) and Basic Issue Items (BII) Lists	0017 00-1
WP 0018 00	Additional Authorization List (AAL)	0018 00-1
WP 0019 00	Expendable and Durable Items List	0019 00-1
	Index	Index-1

HOW TO USE THIS MANUAL

NOTE

If at any time you are unsure how to use this manual or you cannot locate the information you need, notify your supervisor.

INTRODUCTION

1. This manual is designed to help you operate the M878A2 Yard Tractor and perform operator troubleshooting and maintenance on the equipment.
2. This manual is written in work package format:
 - a. Chapters divide the manual into major categories of information (e.g., *Introductory Information with Theory of Operation, Operating Instructions, Operator Troubleshooting, Operator Maintenance Instructions, and Supporting Information*).
 - b. Each Chapter is divided into work packages, which are identified by a 6-digit number (e.g. 0001 00, 0002 00, etc.) located on the upper right-hand corner of each page. The work package page number (e.g. 0001 00-1, 0001 00-2, etc.) is located centered at the bottom of each page.
 - c. If a Change Package is issued to this manual, added work packages use the 5th and 6th digits of their number to indicate new material. For instance, work packages inserted between WP 0001 00 and WP 0002 00 are numbered WP 0001 01, WP 0001 02, etc.
3. Scan through this manual to become familiar with its organization and contents before attempting to operate or maintain the equipment.

CONTENTS OF THIS MANUAL

1. A *Warning Summary* is located at the beginning of this manual. Become familiar with these warnings before operating or performing operator troubleshooting or maintenance on the vehicle.
2. A *Table of Contents*, located in the front of the manual, lists all chapters and work packages in the publication.
 - a. The Table of Contents also provides *Reporting Errors and Recommending Improvements* information and DA Form 2028 addresses, for the submittal of corrections to this manual.
 - b. If you cannot find what you are looking for in the Table of Contents, refer to the alphabetical *Index* at the back of the manual.
3. Chapter 1, *Introductory Information with Theory of Information*, provides general information on the manual and the equipment.
4. Chapter 2, *Operating Instructions*, explains and illustrates all operator controls and indicators and contains a *Stowage and Decal, Data Plate, and Stencil Guide*. It also describes how to perform all operating procedures for the yard tractor: *Operation Under Usual Conditions* and *Operation Under Unusual Conditions*.
5. Chapter 3 covers all *Operator Troubleshooting*. WP 0009 00 contains a *Troubleshooting Symptom Index*. If the M878A2 malfunctions, this index should always be consulted to locate the appropriate troubleshooting procedure.
6. Chapter 4 deals with *Operator Maintenance*: Major areas covered are *Preventive Maintenance Checks and Services (PMCS)* and operator level maintenance tasks.
7. Chapter 5 includes *Supporting Information: References, Components of End Item (COEI) and Basic Issue Items (BII) Lists, Additional Authorization List (AAL), and Expendable and Durable Items List*.

FEATURES OF THIS MANUAL

1. WARNINGS, CAUTIONS, NOTES, subject headings, and other important information are highlighted in **BOLD** print as a visual aid.

WARNING

A WARNING indicates a hazard which may result in death or serious injury.

CAUTION

A CAUTION is a reminder of safety practices or directs attention to usage practices that may result in damage to equipment.

NOTE

A NOTE is a statement containing information that will make the procedures easier to perform.

2. Statements and words of particular interest may be printed in CAPITAL LETTERS to create emphasis.
3. Within a procedural step, reference may be made to another work package in this manual or to another manual. These references indicate where you should look for more complete information.
 - a. If you are told: "Refuel vehicle (WP 0013 00)", go to work package 0013 00 in this manual for instructions on refueling.
 - b. If you are told: "For preparation for storage or shipment procedures, refer to TM 9-2320-312-24", go to TM 9-2320-312-24, which is listed in the *References* work package, for complete information. Use the *Table of Contents* or alphabetical *Index* in TM 9-2320-312-24 to find the procedures.
4. Illustrations are placed after, and as close to, the procedural steps to which they apply. Callouts placed on the art are text or numbers.
5. Numbers located at lower right corner of art (e.g. 376-001; 376-002, etc.) are art control numbers and are used for tracking purposes. Disregard these numbers.
6. Dashed leader lines used in illustrations indicate that called out items are not visible in the view depicted (i.e. they are located within the structure).
7. Technical instructions include metric units as well as standard units. For your reference, a *Metric Conversion Chart* is located on the inside back cover of the manual.

CHAPTER 1
INTRODUCTORY INFORMATION WITH
THEORY OF OPERATION

GENERAL INFORMATION

0001 00

SCOPE

1. **Type of Manual.** This manual is for use in operating and performing operator troubleshooting and maintenance on the M878A2 Yard Tractor.
2. **Equipment Name and Model Number.** Truck, Tractor, Yard Type: 46,662 GVWR, DED, 4 X 2, M878A2.
3. **Purpose of Equipment.** The M878A2 is a 4 X 2 tractor used to move (“spot”) trailers within a terminal yard environment. It is also used in roll-on/roll-off (RO/RO) marine operations. Use of this vehicle on a public road or highway is NOT authorized.

MAINTENANCE FORMS, RECORDS, AND REPORTS

Department of the Army forms and procedures used for equipment maintenance will be those prescribed by DA Pam 738-750, *Functional Users Manual for The Army Maintenance Management System (TAMMS)*, as contained in the Maintenance Management Update.

REPORTING EQUIPMENT IMPROVEMENT RECOMMENDATIONS (EIRs)

If your tractor needs improvement, let us know. Send us an EIR. You, the user, are the only one who can tell us what you don't like about your equipment. Let us know why you don't like the design or performance. Put it on an SF Form 368 (*Product Quality Deficiency Report*). Mail it to us at: Commander, U.S. Army Tank-automotive and Armaments Command, ATTN: AMSTA-LC-CIP-WT, Rock Island, Illinois 61299-7630. We'll send you a reply.

HAND RECEIPT MANUALS

This manual has a companion document with a TM number followed by “-HR” (which stands for Hand Receipt). TM 9-2320-312-10-HR consists of preprinted hand receipts that list end item related equipment (i.e., COEI, BII, and AAL) that must be accounted for. As an aid to property accountability, additional HR manuals may be requisitioned through normal publication channels.

CORROSION PREVENTION AND CONTROL (CPC)

1. Corrosion Prevention and Control (CPC) of Army materiel is a continuing concern. It is important that any corrosion problems with this item be reported so that the problem can be corrected and improvements can be made to prevent the problem in future items.
2. While corrosion is typically associated with rusting of metals, it can also include deterioration of other materials, such as rubber and plastic. Unusual cracking, softening, swelling, or breaking of these materials may be a corrosion problem.
3. If a corrosion problem is identified, it can be reported using SF Form 368 (*Product Quality Deficiency Report*). Use of key words such as “corrosion,” “rust,” “deterioration,” or “cracking” will ensure that the information is identified as a CPC problem. The form should be submitted to the address specified in DA Pam 738-750.

DESTRUCTION OF ARMY MATERIEL TO PREVENT ENEMY USE

For destruction of Army materiel to prevent enemy use, refer to TM 750-244-6.

PREPARATION FOR STORAGE OR SHIPMENT

For preparation for storage or shipment procedures, refer to TM 9-2320-312-24-1.

WARRANTY INFORMATION

The M878A2 Yard Tractor is warranted by Crane Carrier Company, Inc. in accordance with TB 9-2320-312-14. Warranty starts on the date found in block 23, DA Form 2408-9, *Equipment Control Record*. Report all defects in material or workmanship to your supervisor, who will take appropriate action.

NOMENCLATURE CROSS-REFERENCE LIST

COMMON NAME	OFFICIAL NOMENCLATURE
Dipstick	Oil Level Gauge
Engine Coolant	Antifreeze, Ethylene Glycol Mixture
Gladhand	Quick Disconnect Coupling

LIST OF ABBREVIATIONS

NOTE

Refer to ASME Y14.38-1999 for standard abbreviations.

ABBREVIATION	DEFINITION
AAL	Additional Authorization List
BII	Basic Issue Items
C	Centigrade or Celsius
CCC	Crane Carrier Company
cfm	Cubic Feet per Minute
cm	Centimeter
COEI	Components of End Item
ECM	Electronic Control Module
ECU	Electronic Control Unit
F	Fahrenheit
GVWR	Gross Vehicle Weight Rating
HEUI	Hydraulic Electronic Unit Injector
IAP	Injection Actuation Pressure
kg	Kilogram
km	Kilometer
kPa	Kilopascal
kph	Kilometers per Hour
L	Liter
lb-ft	Pound Foot
LCD	Liquid Crystal Display
LED	Light-Emitting Diode
lph	Liters per Hour
mm	Millimeter
Nm	Newton Meter
PMCS	Preventive Maintenance Checks and Services
RO/RO	Roll-On/Roll-Off

END OF WORK PACKAGE

EQUIPMENT CHARACTERISTICS, CAPABILITIES, AND FEATURES1. **Characteristics.**

- a. The M878A2 Yard Tractor moves (“spots”) trailers in a terminal yard environment and in roll-on/roll-off (RO/RO) marine operations. Use of this vehicle on a public road or highway is NOT authorized.
- b. The M878A2 has a Gross Vehicle Weight Rating (GVWR) of 46,662 lb (21,185 kg).
- c. A hydraulically-controlled fifth wheel can be raised or lowered 31 in (79 cm), has a 70,000 lb (31,780 kg) vertical load capacity, and is compatible with a two-inch kingpin.
- d. A cab-controlled, air-operated latching cylinder unlocks fifth wheel coupler jaws from inside the cab.

2. **Capabilities and Features.**

- a. The M878A2 has a wheelbase of 122.00 in (309.88 cm) and an overall length of 198.64 in (504.55 cm).
- b. The maximum speed of the M878A2 is 22.9 mph (36.9 kph). Maximum allowable speed while towing is 15 mph (24 kph).
- c. The M878A2 is equipped with an instrument panel-mounted speedometer and tachometer that register vehicle forward speed and engine speed.
- d. The M878A2 has the following capabilities and features:
 - (1) Caterpillar 7.2L, electronically-controlled, turbocharged, 275 horsepower diesel engine;
 - (2) MD3560P Allison transmission with five (5) forward speeds, neutral, and reverse;
 - (3) Spicer 1710 propshaft;
 - (4) Eaton E-1460I front steering axle;
 - (5) Dana D90-14-2S single rear axle with dual wheels;
 - (6) front and rear air-activated s-cam brakes; rear axle spring-loaded parking brakes;
 - (7) Sheppard power steering gear;
 - (8) air conditioning system;
 - (9) backup lights and alarm;
 - (10) 45-degree cab tilt system;
 - (11) cab sliding rear door; and
 - (12) KBI 40kJ Ultra Capacitor starting system.
- e. A fire extinguisher and an M16 rifle mount are located behind the driver’s seat inside the cab.
- f. An auxiliary arctic heater (WP 0018 00) is available for installation if tractor is to operate in temperatures below -25°F (-32°C).
- g. If installation of an auxiliary radio is desired, wiring is available behind access panel located inside cab above sun visor.

LOCATION AND DESCRIPTION OF MAJOR COMPONENTS

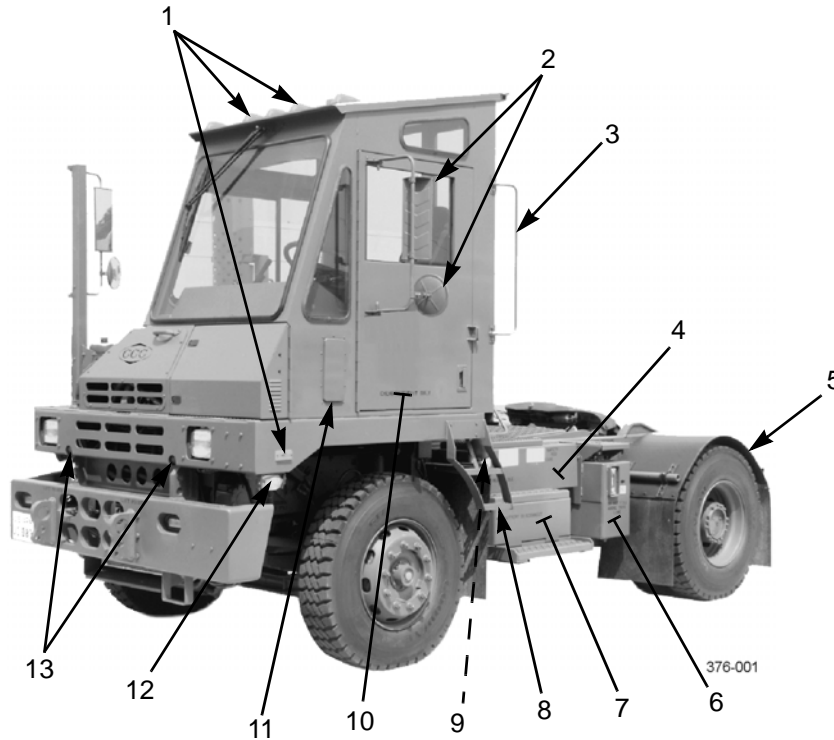

KEY	COMPONENT	DESCRIPTION
1	Marker Clearance Lights	Indicates outline of tractor.
2	Side Mirror and Spotter Mirror	Provide driver with a view to the rear of both sides of tractor and trailer, if towing.
3	Grabhandles	Provide a handhold for personnel climbing on tractor.
4	Cab Tilt Controls	Includes pump, pump controls, and safety prop release cable used to operate cab tilt system.
5	Fender	Prevents water and debris from spraying.
6	Hydraulic Reservoir	Stores hydraulic fluid for operation of power steering system and fifth wheel lift. Contains sight gauge to determine level of fluid in reservoir.
7	Battery Box and Steps	Box holds vehicle batteries, capacitor(s) and 25A ignition system circuit breaker. Steps provide access to rear platform and cab.
8	Steps	Use only in an emergency to exit cab through side door.
9	Slave Receptacle	Receptacle for NATO slave cable to slave start tractor.
10	Side Door	To be used only in an emergency. Use rear sliding door under normal circumstances.
11	Cab Side Vent	Provides ventilation inside cab. Opens and closes from inside cab.
12	Auxiliary Lights	Assist visibility when turning, during night or low light operating conditions.
13	Cab Pivots	Front cab pivots allow for forward tilting of cab.

LOCATION AND DESCRIPTION OF MAJOR COMPONENTS - CONTINUED

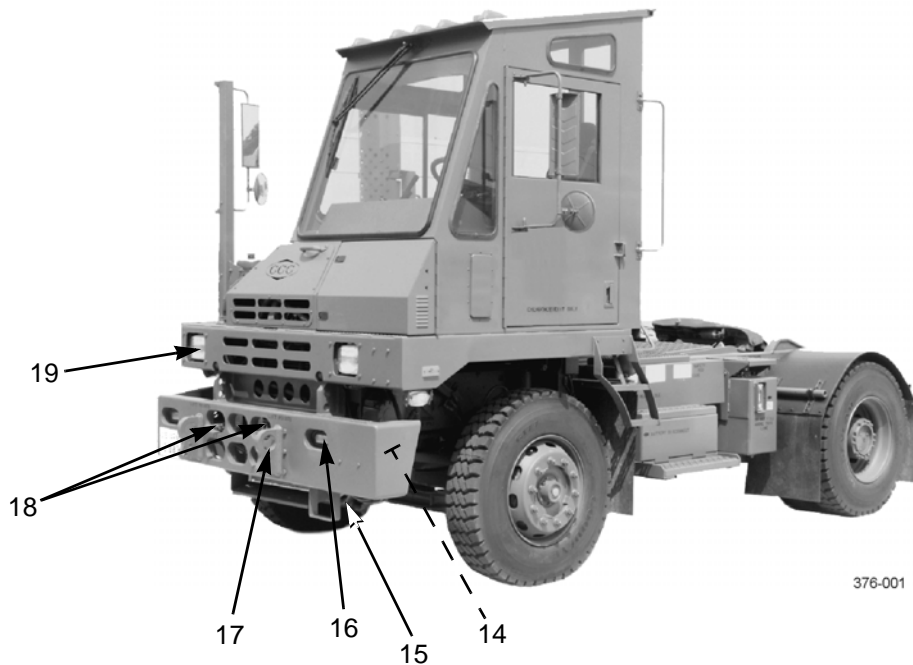

KEY	COMPONENT	DESCRIPTION
14	Windshield Washer Reservoir and Pump	Reservoir and pump supplies windshield washer fluid to windshield.
15	Tiedown Points	Used to tie tractor down when being shipped.
16	Turn Signals	When turned on, flash to indicate direction tractor is turning.
17	Lift and Tow Points	Provide attachment point for lifting and towing devices. Topmost eyes are for lifting; middle and bottommost eyes are for towing tractor.
18	Front Gladhands	Provide service and emergency air connections when tractor is towed from the front.
19	Headlights	Include high and low beam.

LOCATION AND DESCRIPTION OF MAJOR COMPONENTS - CONTINUED

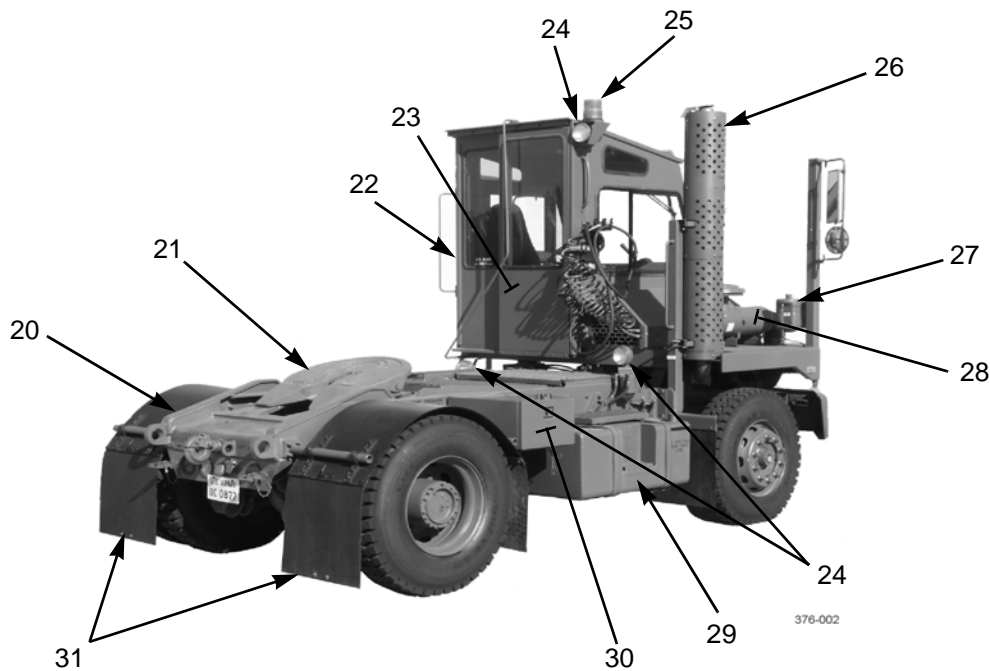

KEY	COMPONENT	DESCRIPTION
20	Ramp	Sloped surface serves as an approach to fifth wheel and facilitates trailer coupling to tractor.
21	Fifth Wheel	Adjustable-height coupling device for trailers with two-inch kingpins. Adjusts from a lowered height of 48 in (122 cm) to a fully raised height of 80 in (203 cm), as measured from top of fifth wheel plate to the ground.
22	Cab	Provides weatherproof enclosure for driver and driver controls.
23	Rear Door	Slides open to allow driver access into cab.
24	Floodlights	Illuminate area to rear of cab, specifically the fifth wheel/kingpin coupling. When floodlight switch is turned to REV, all floodlights also serve as backup lights, when tractor is in R (Reverse).
25	Strobe Warning Light	Flashes to alert other vehicles of presence of tractor.
26	Exhaust Muffler	Deadens noise of engine exhaust.
27	Coolant Overflow Bottle	Contains cooling system overflow. Provides means for operator to visually check coolant level and add coolant to system.
28	Engine Air Cleaner	Filters incoming air to engine intake manifold.
29	Fuel Tank and Steps	Stores fuel supply for vehicle. Steps mounted to tank provide access to cab and rear platform.
30	Stowage Compartment	Provide stowage for BII items and other items.
31	Mudflaps	Prevent water and debris from spraying. Mudflaps may be hooked up out of the way to prevent their damage, when negotiating steep ramps during RO/RO operations.

LOCATION AND DESCRIPTION OF MAJOR COMPONENTS - CONTINUED

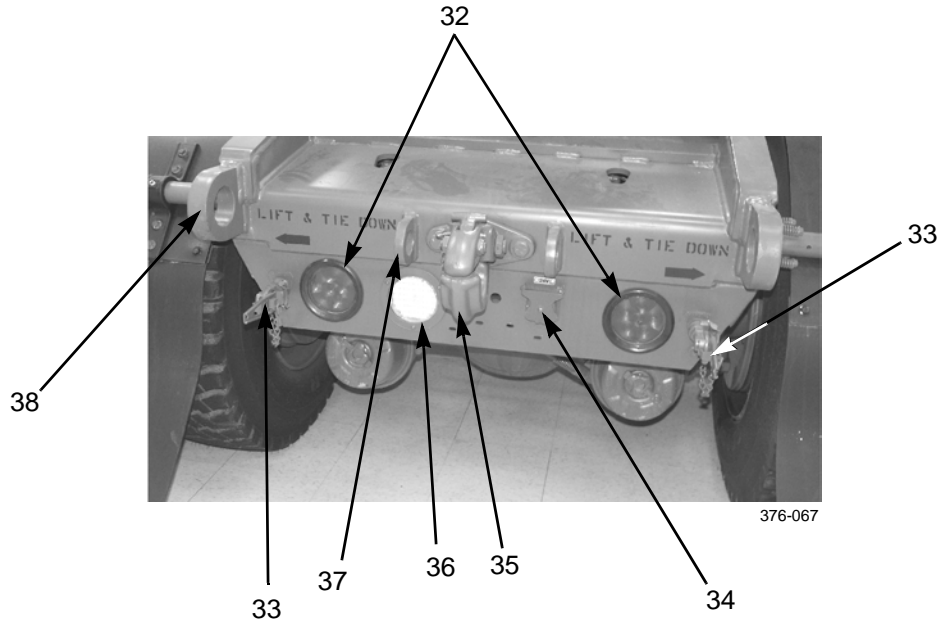

KEY	COMPONENT	DESCRIPTION
32	Taillights	Contain tail, stop, and turn signal lights.
33	Rear Gladhands	Provide service (blue) and emergency (red) air line connections to trailers with lunettes and airbrake systems. Emergency gladhand is also used when a yard tractor tire requires inflation.
34	24V Receptacle	Used when towing military trailers with lunettes.
35	Pintle Hook	Coupling device for trailers with lunettes.
36	Backup Light	Indicates tractor is in reverse gear. Backup alarm will also sound.
37	Safety Chain Stowage Eyes	Allow attachment of safety chains to rear of tractor, when towing trailers with lunettes.
38	Lift and Tiedown Points	Serve as both lift points and tiedown points.

LOCATION AND DESCRIPTION OF MAJOR COMPONENTS - CONTINUED

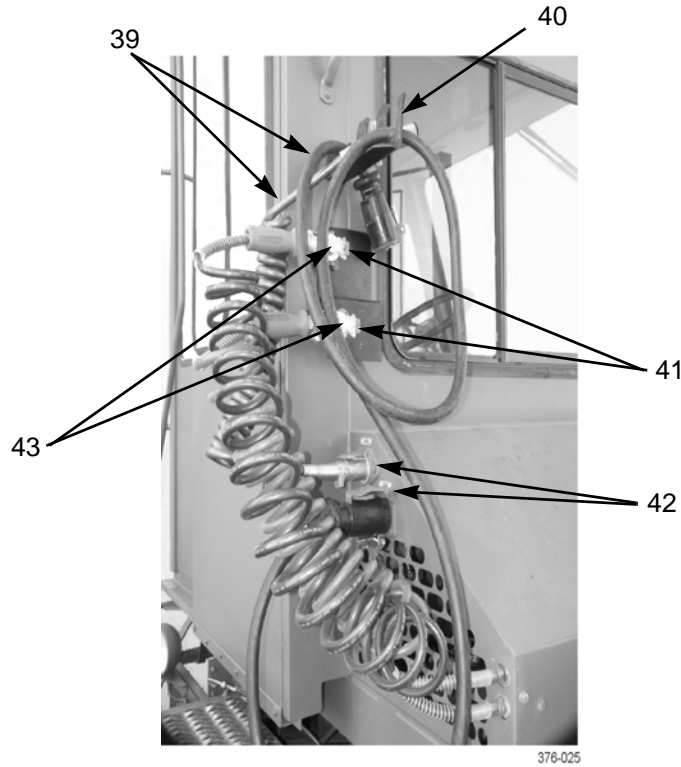

KEY	COMPONENT	DESCRIPTION
39	Intervehicular Electrical Cables	Provide electrical connection to 12-volt (commercial) or 24-volt (military) trailers.
40	Intervehicular Electrical Cable Stowage Bracket	Provides stowage for 12V and 24V electrical cable connectors, when not in use.
41	Dummy Couplings	Provide stowage of trailer air line gladhands.
42	Intervehicular Receptacles	Includes 12-volt and 24-volt electrical receptacles.
43	Intervehicular Gladhands	Provide service (blue) and emergency (red) air line connections to trailers with kingpins.

EQUIPMENT DESCRIPTION AND DATA - CONTINUED

0002 00

EQUIPMENT DATA

Dimensions:

Standard (Metric)

Length (Overall).....	198.64 in (504.55 cm)
Height (Overall).....	124.05 in (315.09 cm)
Width (Overall):	
Front	96.50 in (245.11 cm)
Rear	98.00 in (248.92 cm)
Wheelbase	122.00 in (309.88 cm)
Ground Clearance:	
Front	9.75 in (24.77 cm)
Rear	9.50 in (24.13 cm)
Angle of Approach.....	21.5 degrees
Angle of Departure.....	61 degrees

Weights:

GVWR	46,662 lb (21,185 kg)
------------	-----------------------

Capacities:

Engine Oil	24-27 qt (22.7-25.5 L)
Cooling System	27.5 qt (26.0 L)
Radiator	4.7 gal (17.8 L)
Coolant Recovery Bottle	1.5 gal (5.7 L)
Fuel Tank	50 gal (189.3 L)
Transmission	26 qt (25 L)
Rear Axle (Hub Wheel Ends and Differential)	41 pt (19.4 L)
Hydraulic Reservoir	12 gal (45.2 L)
Hydraulic System (Steering and Fifth Wheel Lift)	15 gal (56.8 L)
Cab Tilt Pump	2 qt (1.9 L)

Engine:

Manufacturer	Caterpillar
Type	Diesel, turbocharged
Model	3126E
Cylinders	6, in-line
Horsepower	275 hp @ 2400 rpm
Displacement	7.2 L (442 in ³)
Oil Filter Type	Full flow, replaceable element
Air Compressor (cfm)	15.0 cfm
Weight (Dry) (With Standard Accessories)	1295 lb (588 kg)
Cold Start Aids.....	Air inlet manifold heater and automatic ether injection

Fuel System:

Type	Hydraulic Electronic Unit Injector (HEUI)
Fuel Filters	Primary fuel filter with fuel/water separator
.....	Secondary fuel filter with hand priming pump

EQUIPMENT DESCRIPTION AND DATA - CONTINUED

0002 00

EQUIPMENT DATA - CONTINUED

Standard (Metric)

Air Cleaner:

Manufacturer	Donaldson
Type	dry element
Quantity	1

Cooling System:

Radiator Working Pressure	7 psi (48 kPa)
---------------------------------	----------------

Electrical System:

Type	12V negative ground
Alternator	Niehoff, 100 amps, dual voltage 12V/24V
Starter	Leece Neville, 24V DC
Batteries:	
Quantity	2 or 4 (if equipped with auxiliary arctic heater)
Cables	Dual Path
Capacitor(s):	
Quantity	1 or 2 (if equipped with auxiliary arctic heater)
Storage Capacity	40kJ; 40 kJ and 120 kJ (if equipped with auxiliary arctic heater)

Transmission:

Manufacturer	Allison
Model	MD 3560P
Type	Automatic, 5-speed forward, neutral, reverse
Shift Selector	Power shift
Filter, Transmission-Mounted	Two, internal, bolt-on cover
Weight (Dry)	575 lb (261 kg)

Front Axle:

Manufacturer	Eaton
Type	E-1460I, left-hand steer, I-beam
Rated Capacity	16,500 lb (7,484 kg)

Rear Axle:

Manufacturer	Dana
Type	D90-14-2S, double reduction planetary
Rated Capacity	70,000 lb (31,751 kg)

Brake System:

Actuation	Air-mechanical
Pressure Range	60-120 psi (414-827 kPa)
Airbrake Chambers	2 per axle

EQUIPMENT DESCRIPTION AND DATA - CONTINUED

0002 00

EQUIPMENT DATA - CONTINUED

Standard (Metric)

Slack Adjusters:	
Front	Automatic
Rear	Manual
Brakeshoes	16.5 in
Parking Brake, Rear Axle	Spring-loaded

Wheels:

Size	22.5 x 8.25, 10 holes
------------	-----------------------

Tires:

Manufacturer	Goodyear
Type	Tubeless, radial
Size	11R22.5, 14 Ply
Load Range	H
Inflation	120 psi (827 kPa)

Steering System:

Power Steering Gear Manufacturer	R.H. Shepperd Co., Inc.
Capacity	14,000 lb (6,350 kg)
Hydraulic Pump	Coupling driven (off engine) 14 gpm priority flow
Steering Wheel	Padded deluxe 18 in diameter, 2-spoke
Steering Column Style	Fixed

Suspension:

Front	4 x 50 in 9-leaf springs, flat leaf, with shock absorbers
Rear	CCC/solid mount

Towing Attachments:

Fifth Wheel:	
Manufacturer	Holland Hitch Co.
Model	FW3500-03344
Fifth Wheel Lift:	
Capacity (Vertical Load)	70,000 lb (31,751 kg)
Lift Height	31 in (79 cm)
PTO Type	Muncie, 10-bolt with 7/8-13T spline
Hydraulic Pump Manufacturer/Part Number	Tyrone/HP16-180C-2NS
Hydraulic Pump Type	3.5 cu in/rev, 3200 psi rated pressure
Hydraulic Lift Cylinder Manufacturer	Cal-West Machining Inc.
Hydraulic Lift Cylinder Type	2-stage, double acting, power up/down
Pintle Hook:	
Manufacturer	Holland Hitch Co., P/N PH760
Maximum Towing Load	40,000 lb (18,143 kg)
Tow Loops (Front, Bumper Integrated)	2
Tow Eyes (Rear, Frame Integrated)	2

EQUIPMENT DESCRIPTION AND DATA - CONTINUED

0002 00

EQUIPMENT DATA - CONTINUED

Standard (Metric)

Cab

■	Style	1-passenger, half-cab, 45-degree tilt
	Construction	Welded steel Galvanneal

Accessories:

Floodlights	Three, illuminate fifth wheel/rear of vehicle
Mirrors	2: 6 in x 16 in, west coast style
.....	2: parabolic
Sliding Rear Door	Back of cab

END OF WORK PACKAGE

INTRODUCTION

1. The M878A2 Yard Tractor consists of the following functional systems:
 - a. drive train;
 - b. fuel system;
 - c. exhaust system;
 - d. cooling system;
 - e. electrical system;
 - f. air system;
 - g. brake system;
 - h. steering system;
 - i. fifth wheel system;
 - j. air conditioning system;
 - k. cab tilt system; and
 - l. optional auxiliary arctic heater system (Refer to *Additional Authorization List*, WP 0018 00).
2. This work package explains how the components and systems of the M878A2 work together. A functional description is provided for each major system.

DRIVE TRAIN

1. The drive train of the M878A2 consists of a Caterpillar 7.2L electronic engine and an Allison MD 3560P transmission, connected to a Spicer 1710 propshaft and Dana D90-14-2S double reduction planetary rear axle.
2. The engine is diesel-fueled and turbocharged, with six in-line cylinders. It generates 275 horsepower at a governed speed of 2400 rpm. Coupled with the Allison automatic transmission, it provides power to handle all requirements of the yard tractor's mission, to include pulling up steep ramps with heavy loads in roll-on/roll-off (RO/RO) naval operations.
3. The engine is equipped with an air inlet manifold heater which assists in cold-weather starting. Heater turns on when sum of coolant temperature and air inlet temperature is less than 109°F (25°C). Heater shuts off when sum of temperatures exceeds 127°F (35°C).
4. An automatic ether cold start system assists in cold-weather starting below 32°F (0°C).
5. The transmission is a torque converter-type with five (5) forward speeds, a N (Neutral), and one R (Reverse) speed. A power take-off, mounted on the transmission, and a hydraulic pump provide hydraulic pressure to operate the hydraulic system for the fifth wheel lift.

FUEL SYSTEM

1. The fuel system uses a Hydraulic Electronic Unit Injector (HEUI) at each cylinder to deliver high-pressure fuel into the combustion chamber. The engine Electronic Control Module (ECM) controls the HEUI fuel system. The HEUI fuel system cannot be mechanically adjusted.
2. Fuel for combustion is supplied by the low-pressure fuel system. The low-pressure fuel system also supplies excess fuel flow to cool the HEUI injectors and to remove air from the system. Components of the low-pressure system are:
 - a. fuel tank with a capacity of 50 gal (189.3 L);
 - b. primary and secondary fuel filters;
 - c. fuel transfer pump; and
 - d. fuel pressure regulator—controls fuel flow back to the fuel tank.

FUEL SYSTEM - CONTINUED

3. The high-pressure fuel system consists of the following:
 - a. HEUI injectors at each cylinder;
 - b. hydraulic pump—pressurizes a portion of the engine lubricating oil to the injection actuation pressure that is required in order to power the HEUI injectors;
 - c. Injection Actuation Pressure (IAP) control valve—a high-precision valve that controls actuation pressure; and
 - d. IAP sensor—monitors actuation pressure and communicates this information to the engine ECM.
4. The 40-micron primary fuel filter also serves as a fuel/water separator. A hand priming pump is mounted to the secondary fuel filter.

EXHAUST SYSTEM

The exhaust system removes exhaust gases from the engine through the exhaust manifold. The gasses flow into exhaust pipes and a muffler to the atmosphere above and to the right side of the cab.

COOLING SYSTEM

1. The cooling system consists of a circulating pump, a standard modulating water temperature regulator (thermostat), a transmission oil cooler, charge air cooler, radiator, and an air-actuated engine fan clutch.
2. The cooling system cools the engine by circulating ethylene glycol-based coolant through the engine and radiator. Coolant is also directed to cool the engine air compressor.

ELECTRICAL SYSTEM

1. The electrical system consists of two 12-volt batteries, 40kJ capacitor and capacitor relay, 100-amp alternator, and voltage regulator that supply power to the engine 24-volt starter and trailer receptacle connectors. Vehicles equipped with arctic heater use four 12-volt batteries and 40kJ and 120kJ capacitors.
2. The KAPower capacitor is an electrical storage device installed in parallel with your vehicle batteries. The capacitor is used, in conjunction with the batteries, to start the engine. Like the batteries, it derives its power from the vehicle charging system and discharges this power when needed to crank the engine.
3. In the event of low or discharged batteries, the vehicle can be started with the isolated available power of the capacitor, by using the emergency start switch.

BATTERIES

CAPACITOR RELAY

EMERGENCY START SWITCH

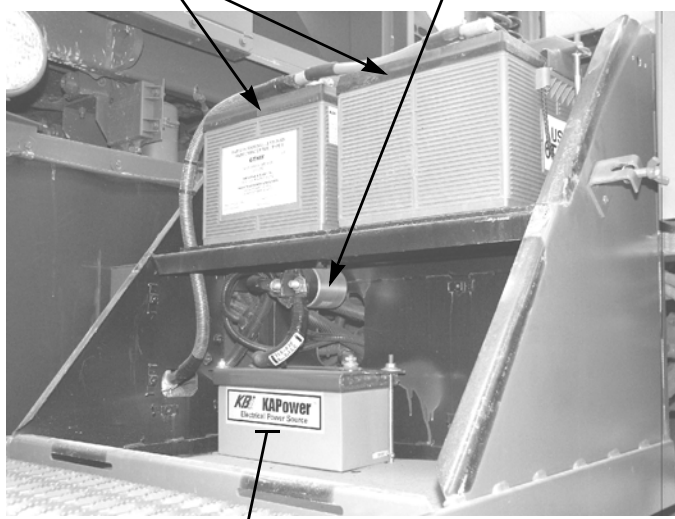

CAPACITOR

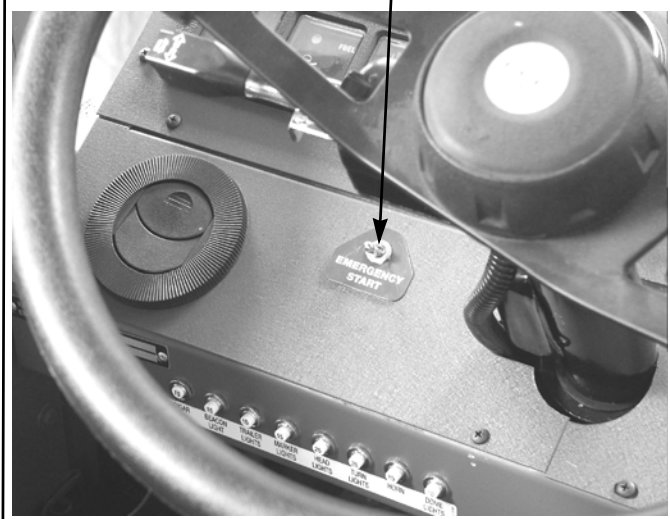

4. The yard tractor is equipped with commercial 12-volt lights to include the following: headlights, marker clearance lights, beacon warning light, floodlights, taillights, and backup light.

AIR SYSTEM

1. The air system supplies clean, dry compressed air to operate the tractor airbrake system and to control miscellaneous air-operated components (fifth wheel unlock and driver's seat). The system consists of an engine-mounted air compressor with governor, air dryer, three air reservoirs with pull-cord drain valves, and air lines and fittings.
2. A dual air pressure gauge on the instrument panel monitors air pressure in both primary and secondary air reservoirs.

BRAKE SYSTEM

1. The M878A2 is equipped with a standard dual airbrake system. Compressed air, generated by the engine-mounted air compressor, is stored in three air reservoirs and distributed, upon demand from the floor-mounted brake pedal, through air lines and valves to airbrake chambers at each wheel.
2. The airbrake system features the following:
 - a. floor-mounted brake pedal (two joined pedals) to operate the tractor (and trailer) brakes;
 - b. manually-operated parking brake control valve to apply and release the tractor parking brakes;
 - c. manually-operated trailer brake control valve to apply and release the trailer service brakes independently of the tractor brakes; and
 - d. manually-operated trailer air supply control valve to apply and release the trailer parking brakes.
3. The mechanical components of the brake system are automatically-adjusting slack adjusters on front axle, manual slack adjusters on rear axle, s-cam camshafts, and 16.5 in brakeshoes.

STEERING SYSTEM

1. The power steering system consists of a engine-mounted hydraulic pump, hydraulic reservoir, power steering gear, and hydraulic hoses. The hydraulic pump provides the power-assist for the steering system.
2. Steering linkage from the steering gear connects to the left side of the Eaton E-1460I front steer axle.

FIFTH WHEEL SYSTEM

1. The M878A2 fifth wheel can be hydraulically raised 31 in (79 cm), using a control lever on the instrument panel. This feature allows for the following:
 - a. adjustment of fifth wheel height to differing trailer coupling heights;
 - b. moving ("spotting") trailers without having to raise their landing gear; and
 - c. negotiating steep ramps during RO/RO procedures.

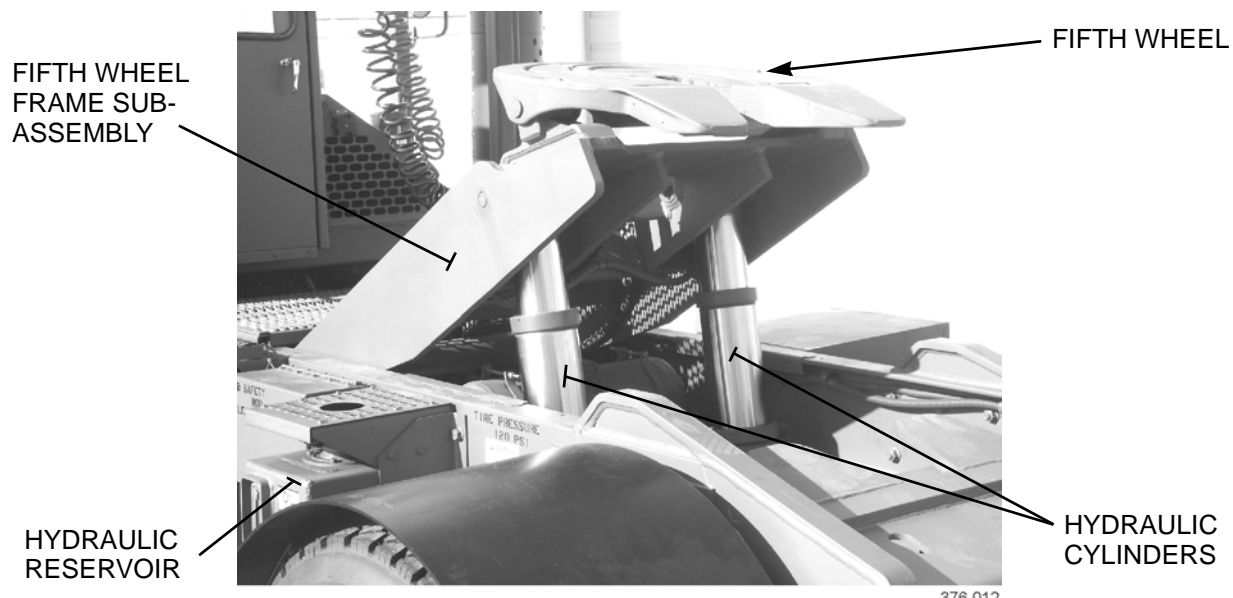

FIFTH WHEEL SYSTEM - CONTINUED

2. The fifth wheel hydraulic system consists of:
 - a. hydraulic pump mounted to transmission-driven PTO;
 - b. hydraulic reservoir (same as for the steering system);
 - c. two hydraulic cylinders mounted between vehicle frame and fifth wheel frame sub-assembly; and
 - d. instrument panel-mounted control valve and lever to raise and lower the fifth wheel from inside the cab.



3. The fifth wheel/kingpin coupling is unlocked from inside the cab using an air-operated control lever on the instrument panel.
4. A load sensing gauge on the instrument panel indicates kingpin weight of trailer on fifth wheel.

AIR CONDITIONING SYSTEM

1. The air conditioning system consists of a belt-driven compressor, condenser, evaporator coil, and receiver-drier.
2. The system utilizes the cab heater, controls, and ductwork to direct cool air throughout the cab interior.

CAB TILT SYSTEM

1. The cab is mounted on the frame with two pivots at the cab front corners and a latch at the left rear corner. The cab may be hydraulically tilted to a maximum of 45° forward to access under the cab for maintenance.
2. The cab tilt pump and controls are located on the left side of the vehicle, directly behind the battery box. Hydraulic fluid from the pump operates a hydraulic cylinder mounted between left side of the cab subframe and the vehicle frame.
3. In the event there is no electrical power to operate the pump, the cab can be manually tilted using a jack handle to operate the pump. When not in use, the handle is stowed inside the cab, behind the driver's seat.

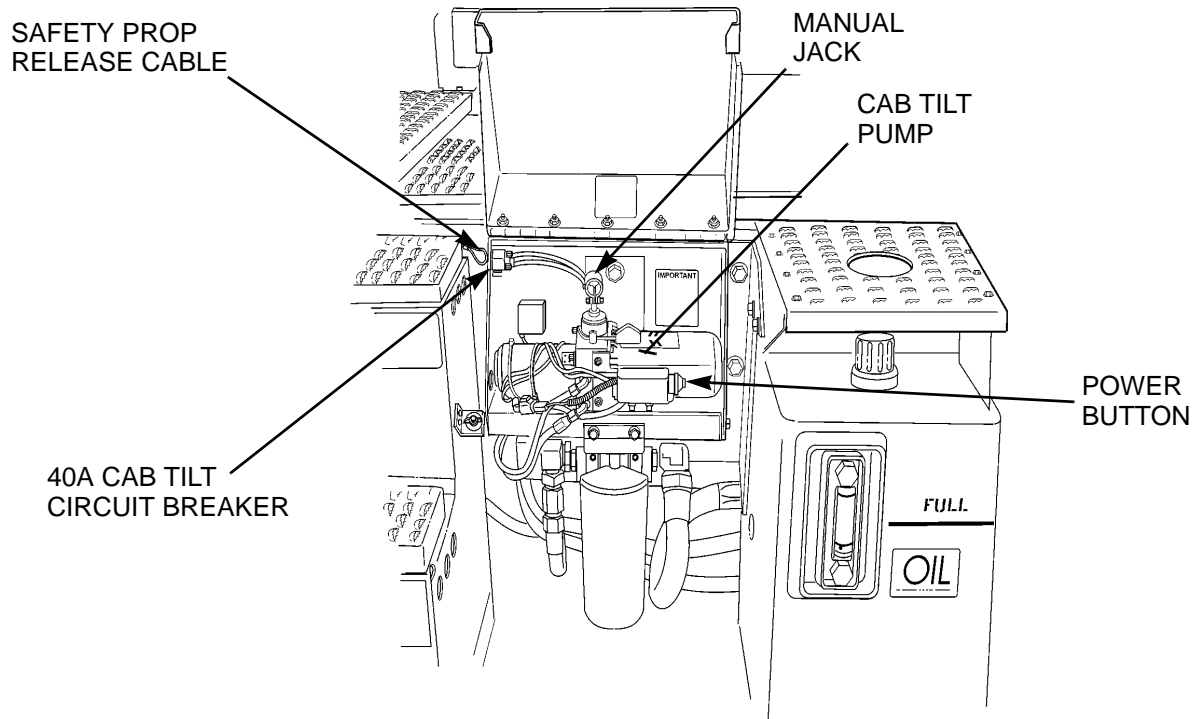

CAB TILT SYSTEM - CONTINUED

4. The safety prop supports the cab when the safety prop latching pin engages notch in prop. When lowering the cab, the safety prop release cable must be pulled so that the safety prop pin will disengage from notch.

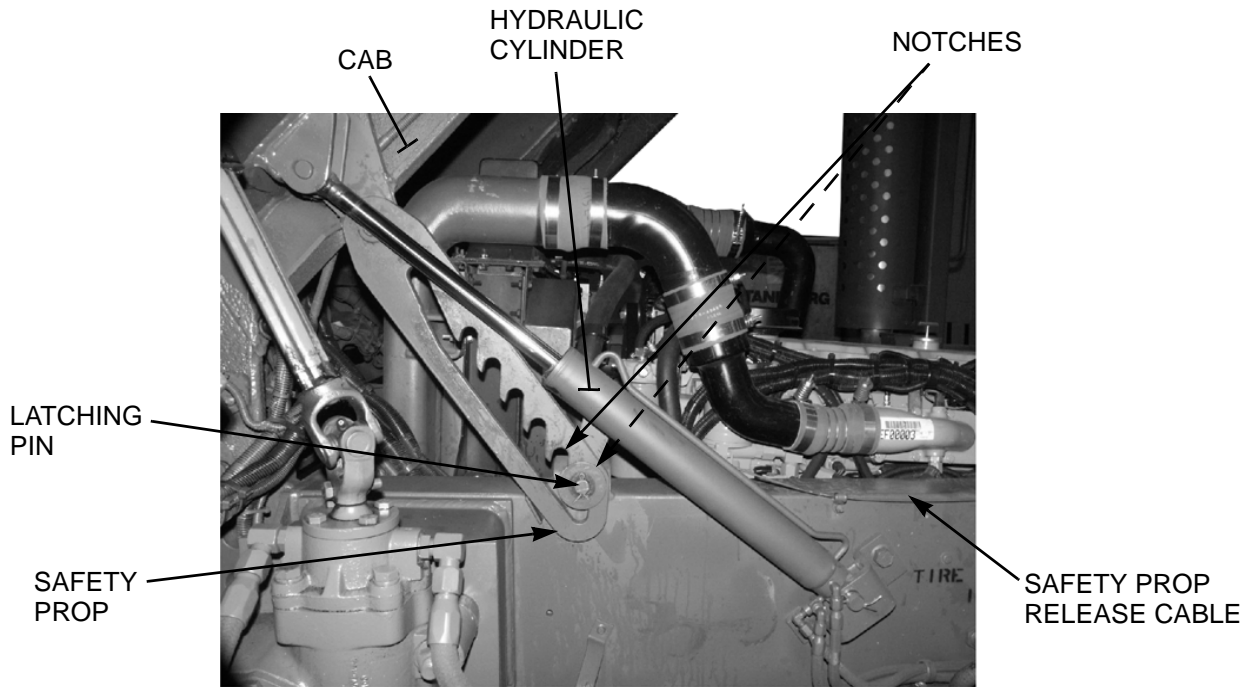

376-022

CAB TILT SYSTEM - CONTINUED

5. The cab is held in the down position by a spring-applied, hydraulically-released latch, at the left-rear corner of the cab.

HYDRAULIC PRESSURE
RELEASES LATCH

LATCH



LOCK
INDICATOR -
PLUNGER IN =
LATCHED

CAB LOWERED

376-021

AUXILIARY ARCTIC HEATER SYSTEM (IF EQUIPPED)

1. The auxiliary arctic heater system is available for installation on vehicles that will operate in temperatures below -25°F (-32°C). The system consists of the following major components:
 - a. coolant heater;
 - b. Thermal Liner® 15 transmission fluid warmer;
 - c. 120 kJ capacitor; and
 - d. two extra batteries.
2. The coolant heater is mounted on the right frame rail at front of tractor. It is connected to the cooling system, electrical system, and fuel system of the vehicle. It functions to preheat the engine block. The heater pumps coolant from the engine, heats it, then returns it to the engine. A temperature regulating switch in the unit regulates the coolant temperature between a low of 154°F (68°C) and a high of 185°F (85°C), by automatically recycling the heater.
3. The Thermal Liner® 15 fluid warmer is installed in-line between the coolant heater and the transmission; it serves to heat transmission oil.

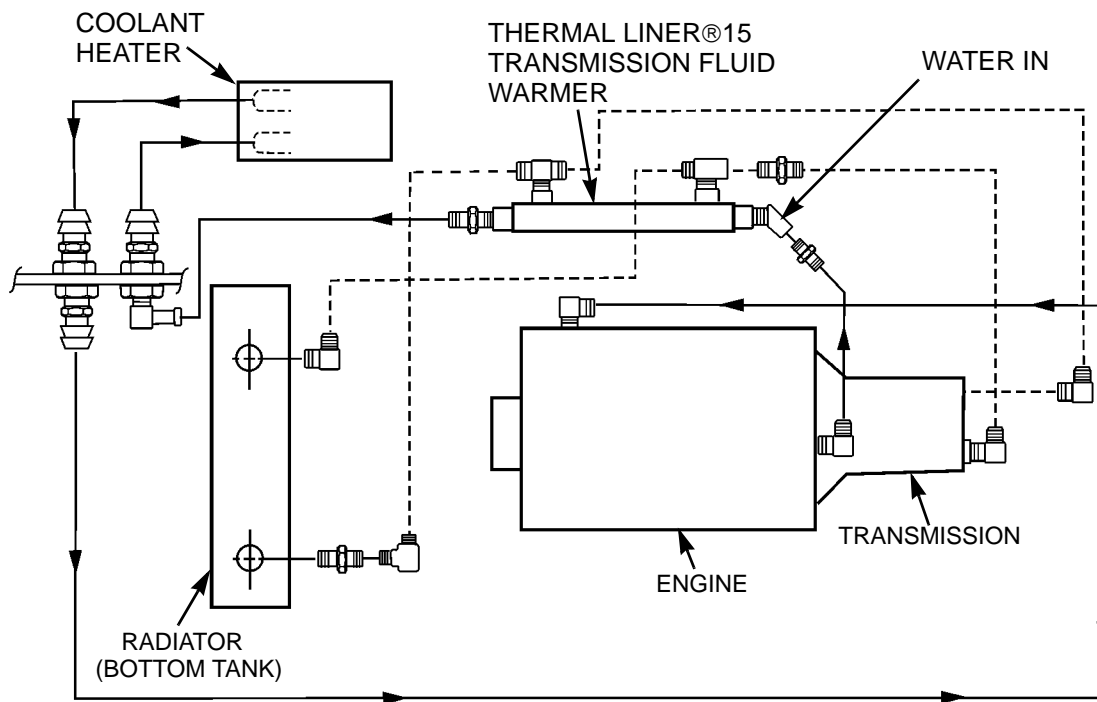

———— = COOLANT

----- = TRANSMISSION FLUID

376-037

4. A 7-day timer, mounted under the left side of the instrument panel, operates the auxiliary arctic heater system and connects to the diagnostic circuit of the coolant heater to allow for troubleshooting capability.
 - a. The timer allows for pre-selection of turn-on time, up to seven (7) days in advance, as well as an option for run times up to 120 minutes before turning off automatically.
 - b. There is also an on/off switch for manual operation.

AUXILIARY ARCTIC HEATER SYSTEM (IF EQUIPPED) - CONTINUED

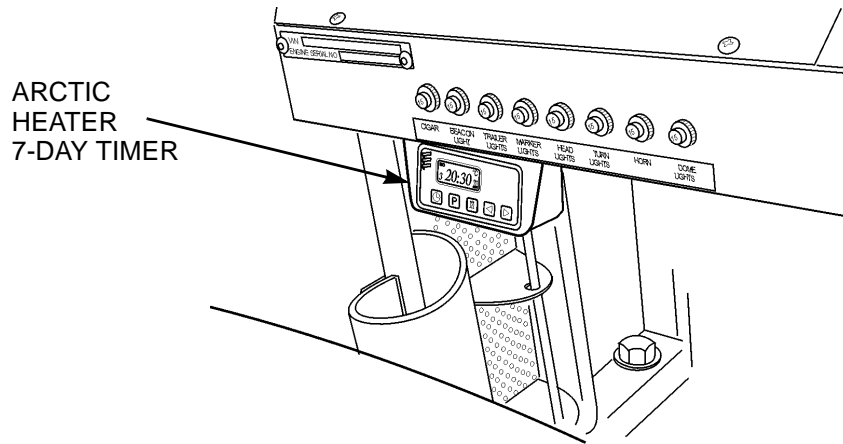

376-013

END OF WORK PACKAGE

CHAPTER 2
OPERATING INSTRUCTIONS

GENERAL

Do not attempt to operate the M878A2 Yard Tractor until becoming familiar with the location and function of all operator controls and indicators. This work package describes all operator controls and indicators.

INSTRUMENT PANEL

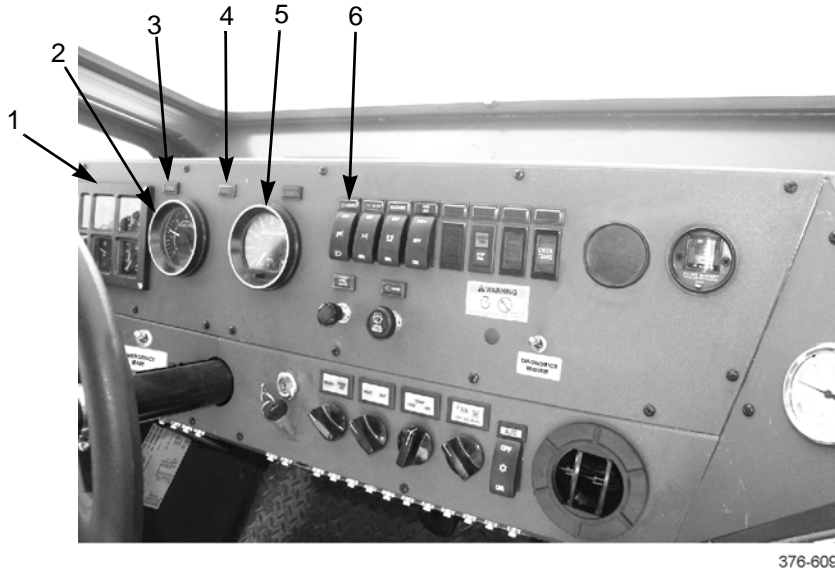

376-609

KEY	CONTROL OR INDICATOR	FUNCTION
1	Instrument and Warning Light Cluster	Contains selected gauges and warning lights that are crucial to safe operation. Refer to <i>Instrument and Warning Light Cluster</i> on page 0004 00-06 for more information.
2	Tachometer/Hourmeter	Tachometer indicates speed of engine in rpm. Hourmeter indicates total hours of engine operation.
3	Turn Signal Indicators	Left/right green light flashes whenever turn signals are flashing. Both lights flash when hazard warning flasher is on.
4	High Beam Indicator	Blue light comes on when high beam headlights are on.
5	Speedometer/Odometer	Speedometer indicates vehicle forward speed. Odometer indicates total distance traveled. Includes a trip meter that may be reset.
6	Headlight Switch	Three-position rocker switch controls parking lights and headlights. OFF is all the way forward. Middle position is for parking lights and all the way back position controls headlights.

INSTRUMENT PANEL - CONTINUED

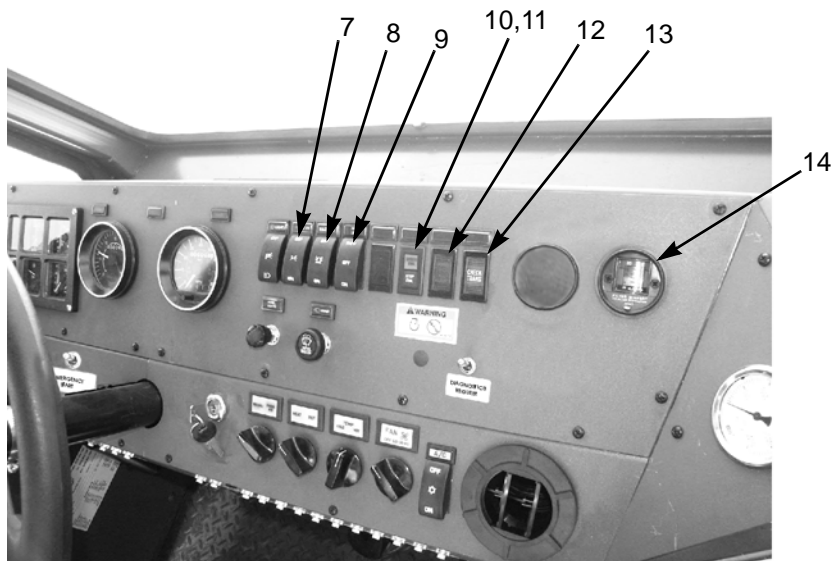

376-609

KEY	CONTROL OR INDICATOR	FUNCTION
7	Marker Clearance and Auxiliary Light Switch	ON/OFF rocker switch turns marker clearance lights and auxiliary lights on and off.
8	Hazard Light Switch	ON/OFF rocker switch controls beacon warning light.
9	Floodlight Switch	Three-position rocker switch controls floodlights on cab. REV position turns floodlights on when yard tractor is in reverse. Middle position is OFF. ON position turns floodlights on.
10	Check Engine (CHK ENG.) Light	Amber light indicates engine malfunction. Vehicle mission may be completed. Light also flashes troubleshooting flash codes when maintenance personnel activate this function.
11	Stop Engine (STOP ENG.) Light	Red light indicates vehicle must be stopped immediately due to engine malfunction.
12	Engine Preheat (ENG PREHEAT) Light	Amber light comes on when air inlet manifold heater is on.
13	CHECK TRANS Light	Amber light indicates transmission Electronic Control Unit (ECU) has signaled a troubleshooting diagnostic code.
14	Air Cleaner Restriction Indicator and Reset Button	Gauge indicates air cleaner airflow is adequate if yellow band is in green zone on gauge. If restricted, yellow band will rise to red area on gauge. After air cleaner is serviced, press yellow reset button at bottom of gauge before resuming operation.

INSTRUMENT PANEL - CONTINUED

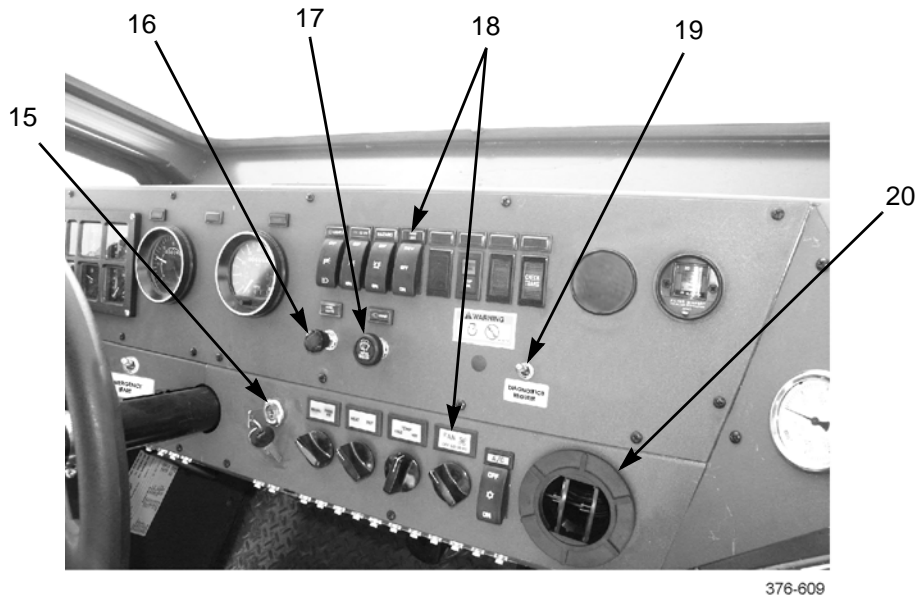

KEY	CONTROL OR INDICATOR	FUNCTION
15	Ignition Switch	Four-position keyed switch. Positions are OFF and (clockwise) ON and START. Counterclockwise position (ACC) is not used.
16	Panel Light Switch	Operates only with headlight switch on. Turn knob one stop clockwise to turn panel lights on to maximum intensity. Continue to turn clockwise to decrease intensity. All the way counterclockwise turns panel lights off.
17	Windshield Wiper and Washer Control	Turn wiper on by turning knob clockwise to desired speed. First stop is normal speed. Second stop is high speed. Shut off by turning knob counterclockwise. To use washer, turn wiper on normal speed and push in on knob to spray washer fluid. Fluid will continue to spray as long as knob is pushed in.
18	Panel Lights	Identify switches when operating in low light conditions or at night.
19	Engine Diagnostic Switch (DIAGNOSTICS REQUEST)	Maintenance personnel activate switch when performing troubleshooting, in order to access flash codes.
20	Heater/Air Conditioner Air Outlets	Vent air into cab from heater/air conditioner. Louvered openings are adjustable.

INSTRUMENT PANEL - CONTINUED

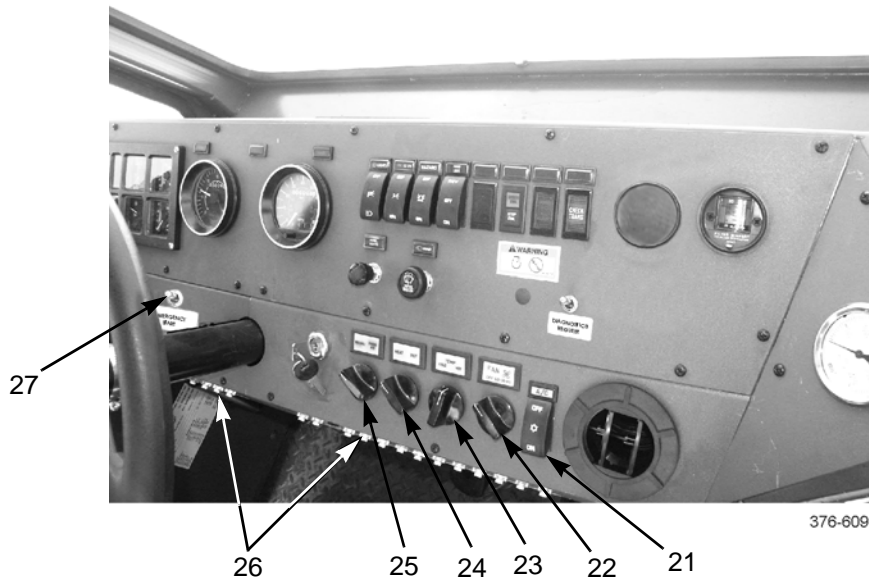

KEY	CONTROL OR INDICATOR	FUNCTION
21	Air Conditioner (AC) Switch	ON/OFF rocker switch turns air conditioner on and off.
22	Heater/AC Fan Switch	Rotary switch adjusts three-speed fan. Rotate clockwise to increase fan speed, counterclockwise to decrease. Positions on switch are OFF, LO, M, and HI.
23	Heater Temperature Control	Adjusts heater output temperature. Rotate knob clockwise to increase temperature (HOT), counterclockwise to decrease (COLD).
24	Defroster/Heater Control	Rotate knob to select HEAT or DEF (defrost) mode.
25	Fresh/Recirculate Air Control	Allows choice of FRESH (outside) AIR or RECIRC. (recirculated) air to be used with AC and HEAT modes.
26	Circuit Breakers	Protect various electrical circuits from overload. If a component does not operate, push associated circuit breaker to reset.
27	Emergency Start Switch	Spring-loaded toggle switch used to start engine using capacitor power, when batteries are low or discharged. If engine will not crank, turn ignition switch to ON, hold emergency start switch in up (ON) position, then start engine.

INSTRUMENT PANEL - CONTINUED

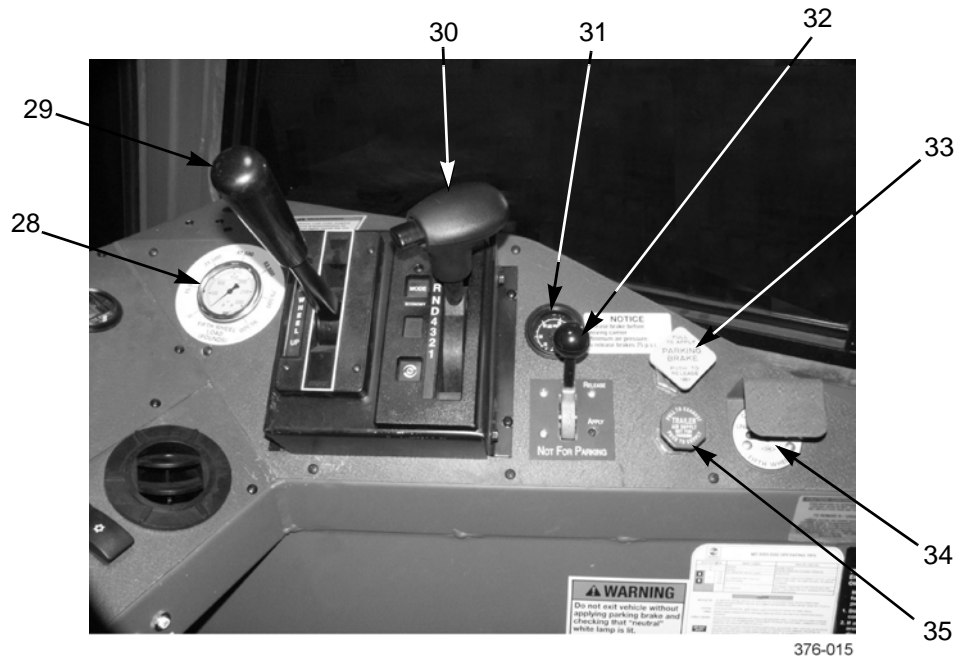

376-015

KEY	CONTROL OR INDICATOR	FUNCTION
28	Load Sensing Gauge	Indicates kingpin weight of trailer on fifth wheel. Weight must not exceed 70,000 lb (31,751 kg) vertical load capacity.
29	Fifth Wheel Lift Control	With engine running and transmission in any range, move lever to UP position to raise fifth wheel, to DN position to lower fifth wheel.
30	Transmission Range Selector Lever	Lever shifts automatic transmission. Positions are R (Reverse), N (Neutral), D (Drive), and specific drive gear ranges: 4; 3; 2; and 1. R (Reverse) also activates backup lights, floodlights, and a backup alarm. Refer to <i>Transmission Range Selector Lever</i> on page 0004 00-15 for more information.
31	Air Pressure Gauge	Two-needle (green and orange) gauge indicates air pressure in primary and secondary brake systems. Pressure should range between 85-130 psi (586-896 kPa). If pressure is below 65 psi (448 kPa), warning buzzer sounds and warning light comes on.
32	Trailer Brake Control Valve	Applies trailer service brakes without applying tractor service brakes. Pull lever down to apply trailer brakes. Push lever up to release trailer brakes. DO NOT use lever as a trailer parking brake.
33	Parking Brake Control	Yellow diamond-shaped knob operates tractor parking brake valve. Pull out to apply parking brake, push in to release.
34	Fifth Wheel Lock Control	Move lever left to unlock fifth wheel coupler jaws. Lever automatically returns to right (lock) position when released.
35	Trailer Air Supply Control	Red octagonal-shaped knob supplies air to trailer air reservoirs. Push in to charge trailer air supply and release trailer parking (spring) brakes. Pull out to shut off air supply and apply trailer parking (spring) brakes.

INSTRUMENT AND WARNING LIGHT CLUSTER

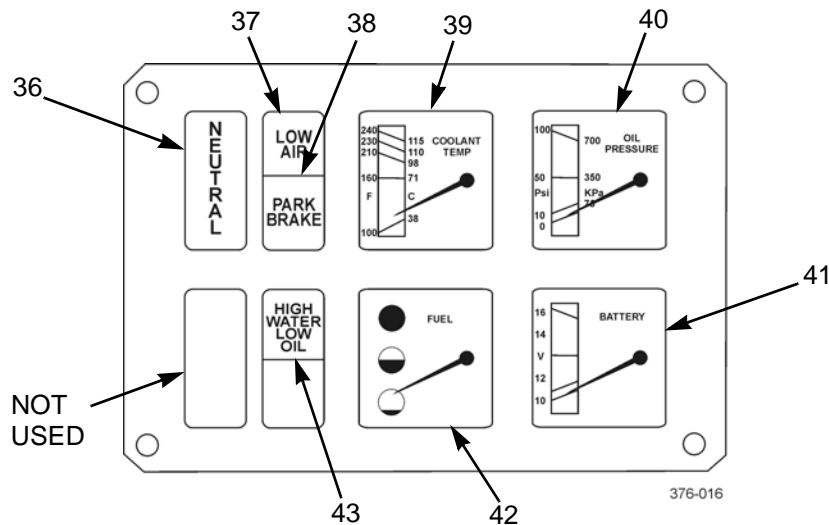

KEY	CONTROL OR INDICATOR	FUNCTION
36	Transmission Neutral Indicator Light	Light (NEUTRAL) is on when transmission is in neutral.
37	Low Air Warning Light	Warning light (LOW AIR) comes on when air pressure in one or both airbrake system reservoirs drops below 65 psi (448 kPa). Warning light comes on at engine startup and remains on until a minimum of 65 psi (448 kPa) in airbrake system is reached.
38	Parking Brake Indicator Light	Light (PARK BRAKE) comes on when parking brake is activated.
39	Coolant Temperature Gauge	Normal safe operating range is in green area on gauge. Typical temperature range is 190-215°F (88-102°C). Higher temperatures may occur intermittently under certain conditions.
40	Engine Oil Pressure Gauge	Typical oil pressure at rated speed is 35-70 psi (240-480 kPa). If oil pressure drops below 5 psi (35 kPa), HIGH WATER LOW OIL warning light and alarm will come on.
41	Voltmeter	Indicates rate of battery charge or discharge in volts: <ul style="list-style-type: none"> • Pointer in GREEN area on gauge shows normal battery condition (13.5-14.0V). • Pointer in upper (RED) area indicates overcharge condition. In no instance should voltmeter register above 14.5-15.0V. • Pointer in lower (YELLOW or RED) area indicates undercharge condition. If battery is discharged to any extent, voltage may read as low as 12.0-13.0V. When voltmeter shows either an undercharged or overcharged condition for an extended period, notify maintenance personnel.

INSTRUMENT AND WARNING LIGHT CLUSTER - CONTINUED

KEY	CONTROL OR INDICATOR	FUNCTION
42	Fuel Gauge	Gauge shows approximate level of fuel in tank. Gauge is divided into segments: empty (red), ½ full (orange), and full (green).
43	High Water Temperature/Low Oil Pressure Warning Light	Light (HIGH WATER LOW OIL) comes on and alarm sounds when coolant temperature exceeds 230°F (110°C) or engine oil pressure drops below 5 psi (35 kPa). Shut down engine immediately. Check oil and coolant levels and add as required. Contact Unit Maintenance if oil and coolant levels are OK. Light and alarm come on for a few seconds at engine startup, then turn off.

STEERING WHEEL AND COLUMN-MOUNTED CONTROLS

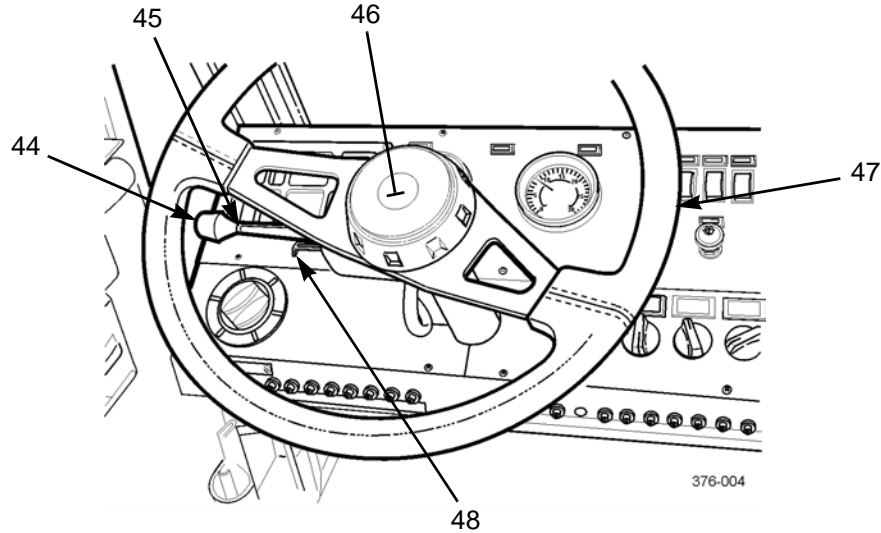

KEY	CONTROL OR INDICATOR	FUNCTION
44	Headlight Dimmer Switch	Press button on end of turn signal lever to turn on headlight high beams. Press button again for low beams.
45	Turn Signal Lever	Move lever forward for right turn signal; rearward for left turn signal.
46	Horn	Push to sound horn.
47	Steering Wheel	Turn clockwise to steer vehicle right; counterclockwise to steer left.
48	Hazard Flasher Switch	With turn signal in center (off) position, pull out on switch until it locks into position. To turn off flashers, move turn signal lever either forward or rearward, then to center (off) position.

CAB FLOOR-MOUNTED CONTROLS

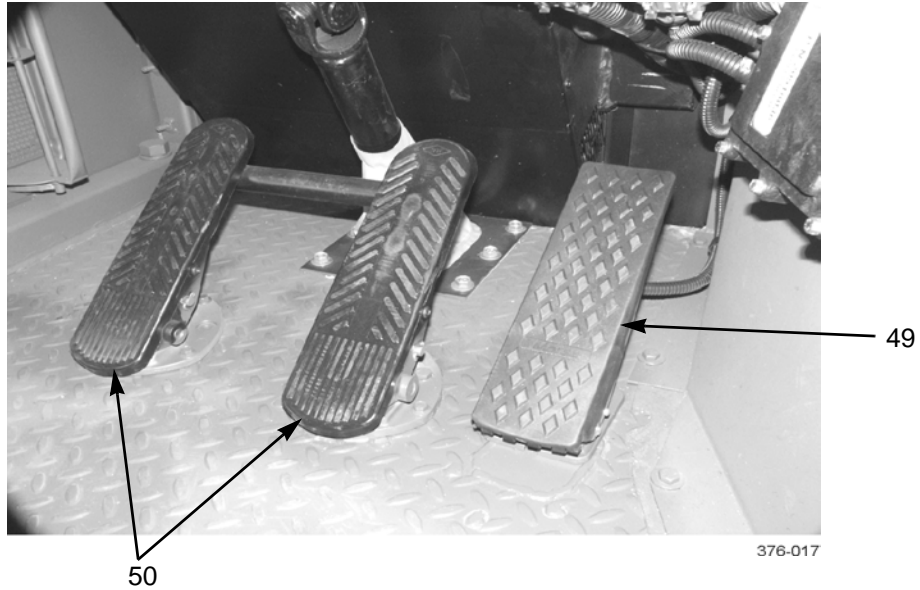

KEY	CONTROL OR INDICATOR	FUNCTION
49	Throttle Position Sensor (Accelerator Pedal)	Electronic throttle controls engine speed. Depress pedal to increase engine speed. Release pedal to decrease speed.
50	Brake Pedals	Depress either pedal to apply service brakes on tractor and on trailer (if coupled). Release pedal to release brakes.

SEAT AND SEAT BELT CONTROLS

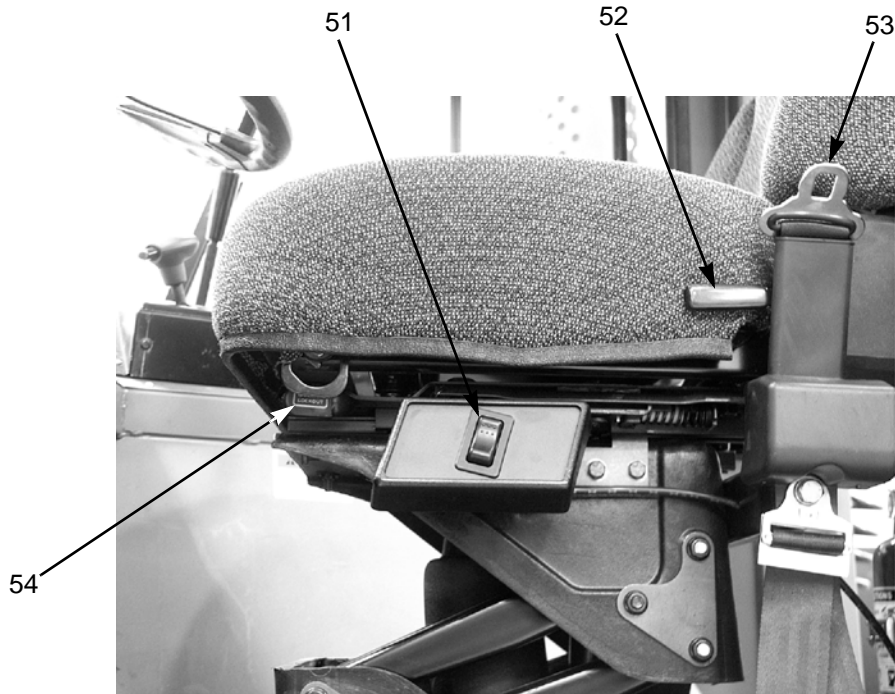

376-005

KEY	CONTROL OR INDICATOR	FUNCTION
51	Height Adjustment Lever	To raise seat, depress top of toggle switch. To lower seat, depress bottom of toggle switch.
52	Seatback Angle Adjustment Lever	Lean slightly forward to remove pressure from seat, then pull up on lever to adjust seatback to any position within adjustment range. Release lever to lock adjustment in place.
53	Seat Belt	Lap belt must be used whenever tractor is in motion. Retractor is on left side of seat, buckle on right side.
54	Fore and Aft Position (ISOLATOR LOCKOUT) Lever	Hold lever to left while adjusting seat position. Release lever when adjusted position is reached. Push lever firmly inward to lock seat position.

SEAT AND SEAT BELT CONTROLS - CONTINUED



376-006

KEY	CONTROL OR INDICATOR	FUNCTION
55	Lumbar Adjustment Lever	Depress lever to increase lumbar support. Raise lever to decrease lumbar support.

CAB TILT SYSTEM CONTROLS

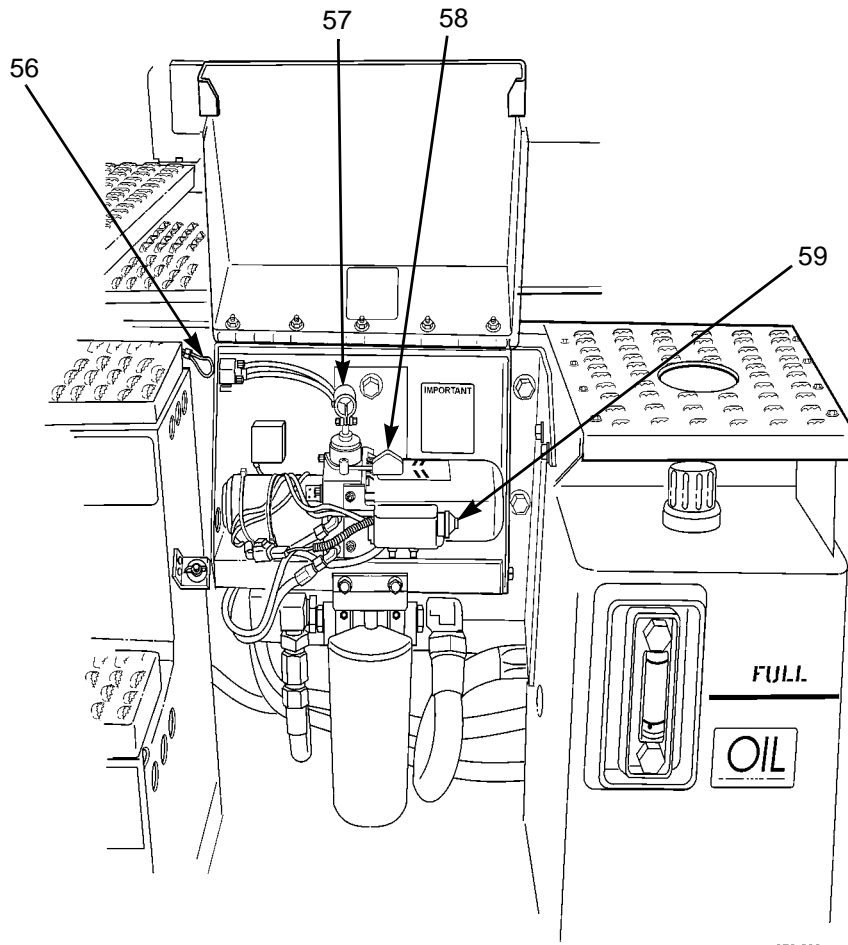

376-003

KEY	CONTROL OR INDICATOR	FUNCTION
56	Safety Prop Release Cable	Pull on cable to disengage cab tilt safety prop.
57	Pump Manual Jack	Allows manual functioning of cab tilt pump. Handle to operate jack is stowed inside cab behind driver's seat.
58	Cab Tilt Lever	Controls raising and lowering of cab. Turn lever toward front of vehicle to lower cab. Turn lever toward rear of vehicle to tilt cab.
59	Pump Power Button	Press button to activate pump.

CAB TILT SYSTEM CONTROLS - CONTINUED



60
 PLUNGER IN =
 LATCHED

376-021

UNDER CAB—LEFT-REAR CORNER

KEY	CONTROL OR INDICATOR	FUNCTION
60	Cab Latch Lock Indicator	When plunger is in, cab is latched. When plunger is out, cab is unlatched.

FIFTH WHEEL CONTROLS

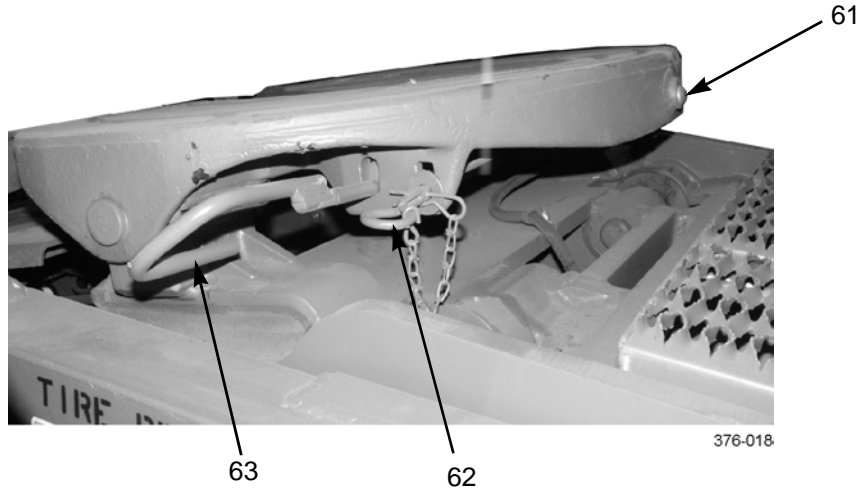

KEY	CONTROL OR INDICATOR	FUNCTION
61	Yoke Shaft	When extended as shown, indicates fifth wheel coupler jaws are open. When retracted, indicates jaws are locked closed and coupling with trailer is secure.
62	Manual Secondary Lock Handle	Manually locks fifth wheel jaws. To engage (lock), remove hairpin clip from handle and allow secondary lock to pivot closed. Reinstall clip. To disengage (unlock), remove hairpin clip and pull handle outward. While holding handle out, reinstall clip.
63	Release Arm	Manually unlocks fifth wheel jaws in case of failure of fifth wheel lock control on instrument panel inside cab. With manual secondary lock handle disengaged, pull out on release arm until fifth wheel jaws lock in open position and release arm stays out.

TRANSMISSION RANGE SELECTOR LEVER

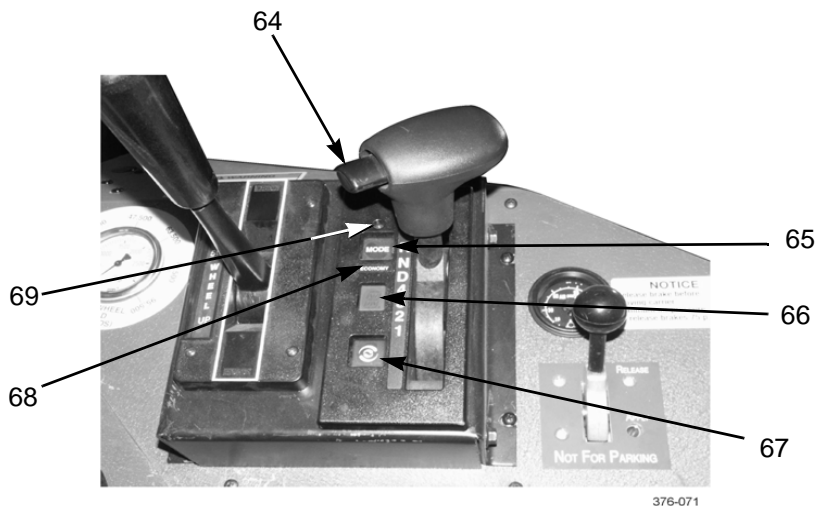

KEY	CONTROL OR INDICATOR	FUNCTION
64	Hold Override Button	Press button to shift between R (Reverse), N (Neutral), and D (Drive). Release button once selector position is reached. Range selector lever may be moved freely between D (Drive) and numbered forward ranges without pressing button.
65	Mode Button	Allows access to view more than one logged diagnostic code (2nd through 5th code positions).
66	Digital Display	During normal mode, displays transmission range selected by range selector lever. When D (Drive) is selected, display shows highest forward range attainable for shift schedule in use. Display also indicates abnormal operation: <ul style="list-style-type: none"> • When display is blank, there is no power to the selector. • When display is flashing, a transmission malfunction has occurred; CHECK TRANS light will also be on. • When display mode/diagnostic button and mode button are pressed, digital display flashes up to five error code positions.
67	Display Mode/Diagnostic Button	Allows access to troubleshooting diagnostic code information. Press once to obtain diagnostic code information. Press again to return digital display to normal mode.
68	Mode ID	Indicates which position diagnostic code is being viewed on digital display.
69	Mode Indicator LED	Red light comes on when mode button is pressed.

ADDITIONAL CONTROLS AND INDICATORS



376-021

KEY	CONTROL OR INDICATOR	FUNCTION
70	Ether Control Relay Indicator Light	Red LED indicates low fluid in automatic ether injection system cylinder.
71	Fuel Priming Pump Plunger	Allows fuel system priming in the event engine fails to start. Rotate counterclockwise to open pump. Operate plunger until a strong pressure is felt. Tighten securely all the way clockwise after use.

ADDITIONAL CONTROLS AND INDICATORS - CONTINUED

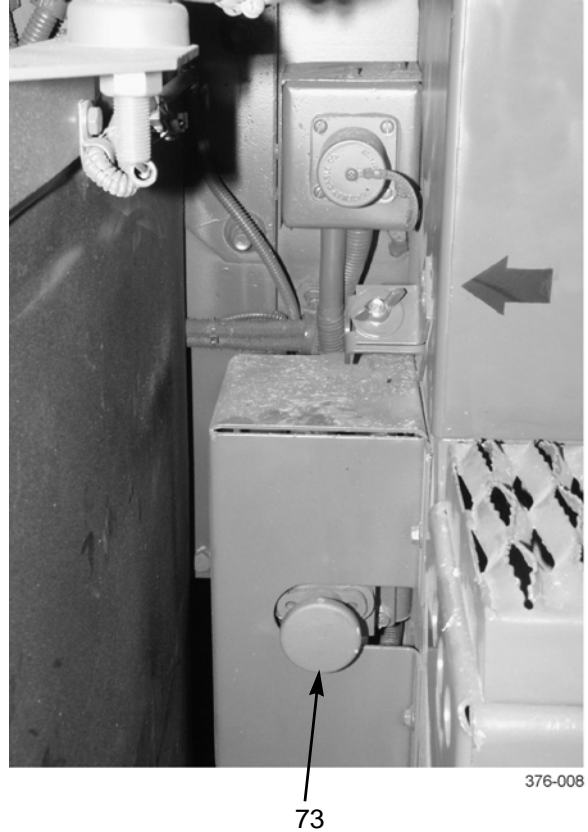
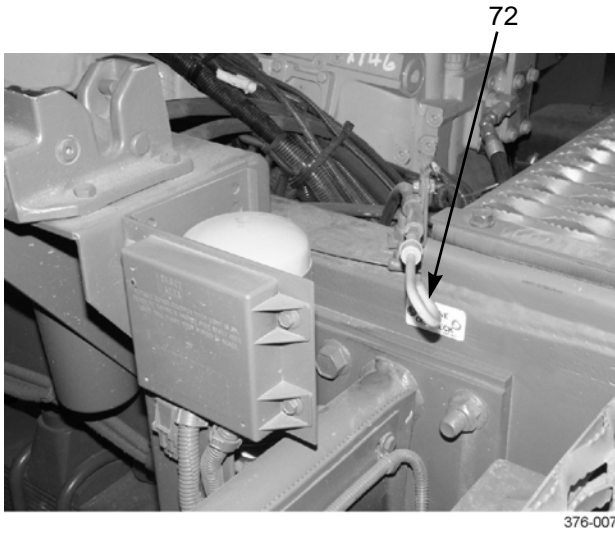

KEY	CONTROL OR INDICATOR	FUNCTION
72	Engine Oil Level Gauge	Indicates level of engine oil in engine crankcase. Level should be within cross-hatched area (OPERATING RANGE) on dipstick.
73	Battery Disconnect Switch	Cuts off battery power from all vehicle electrical systems. Push in for ON. Pull out for OFF. Normally, leave switch in ON position. Place in OFF position under the following circumstances: <ul style="list-style-type: none"> • in the event of an accident or other emergency, to prevent fire • for long-term (over 30 days) storage • to perform electrical system maintenance

ADDITIONAL CONTROLS AND INDICATORS - CONTINUED

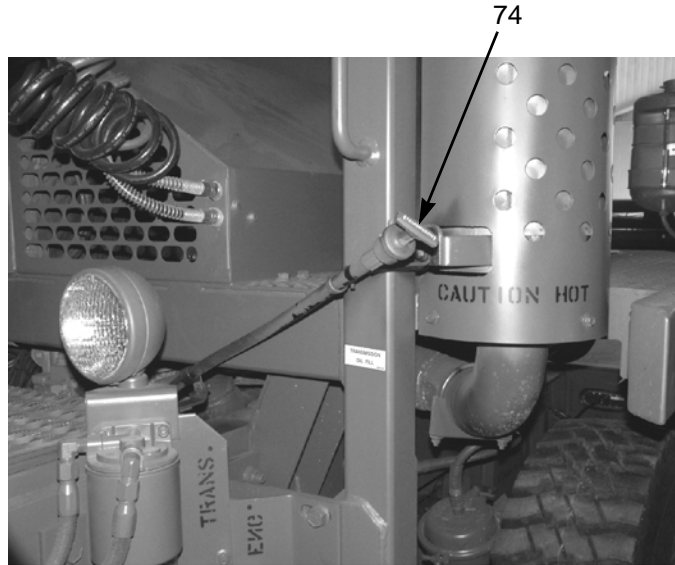

376-650

KEY	CONTROL OR INDICATOR	FUNCTION
74	Transmission Oil Level Gauge	Indicates level of transmission fluid in transmission. If transmission is cold, level on dipstick should be between COLD ADD and COLD FULL lines. If warmed up, level should be between HOT ADD and HOT FULL lines on dipstick.

ADDITIONAL CONTROLS AND INDICATORS - CONTINUED

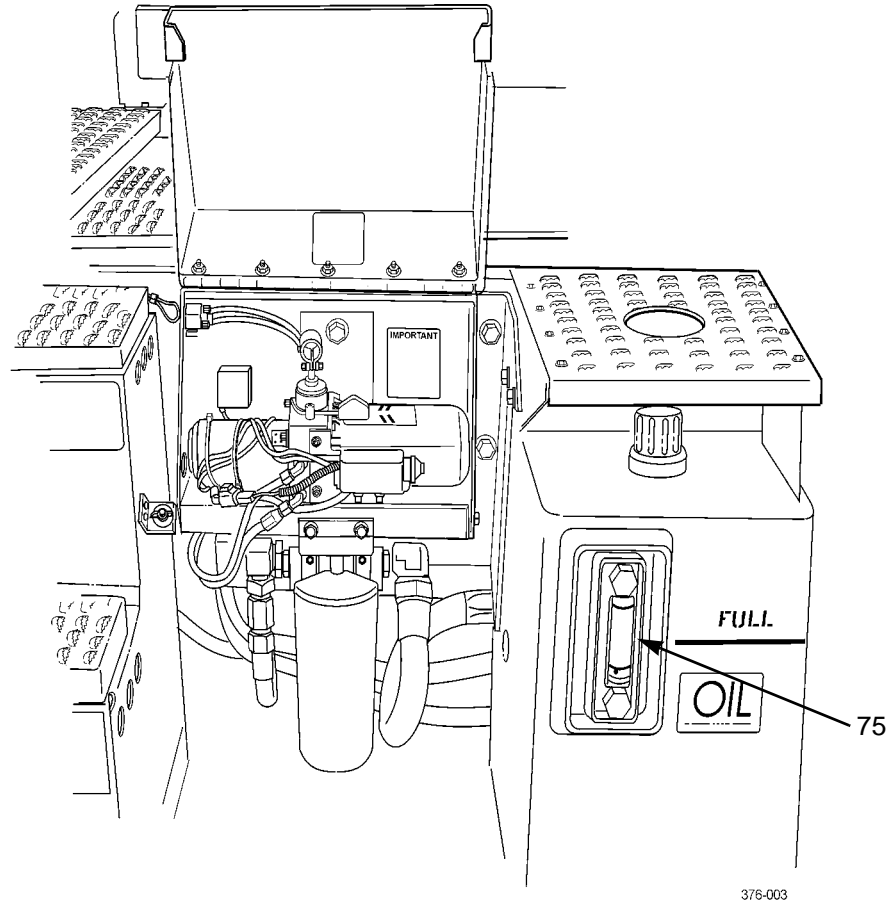

376-003

KEY	CONTROL OR INDICATOR	FUNCTION
75	Hydraulic Reservoir Sight Gauge	Indicates level of hydraulic fluid in reservoir. With fifth wheel fully lowered, level of fluid should be level with FULL line stenciled on reservoir DO NOT fill above this line.

ADDITIONAL CONTROLS AND INDICATORS - CONTINUED

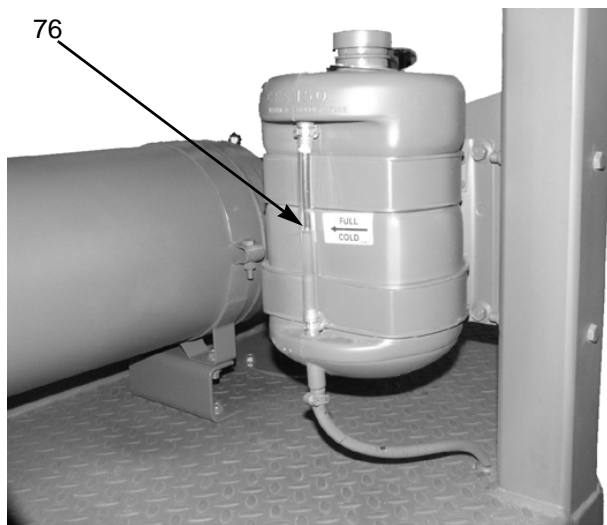

376-026

KEY	CONTROL OR INDICATOR	FUNCTION
76	Coolant Overflow Bottle Sight Glass	Indicates level of coolant in cooling system. With engine cold, level of coolant should be at FULL COLD mark on sight glass.

ADDITIONAL CONTROLS AND INDICATORS - CONTINUED

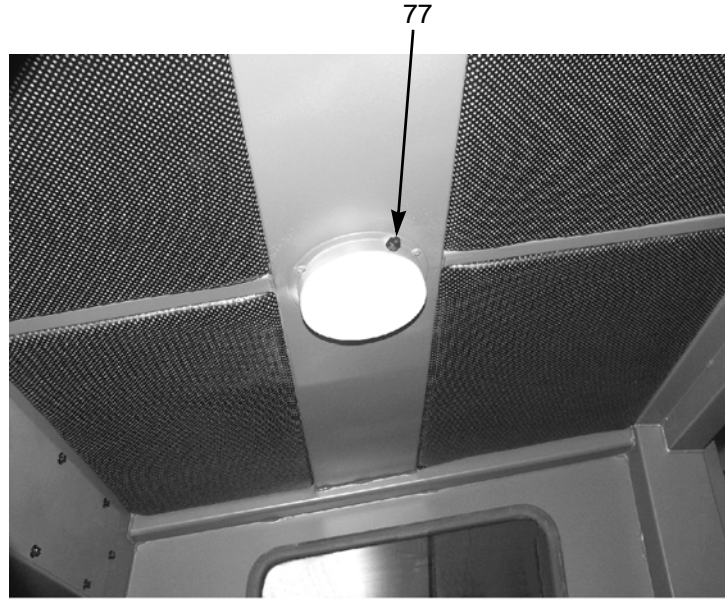

376-05C

KEY	CONTROL OR INDICATOR	FUNCTION
77	Domelight Switch	Press to turn on domelight. Press again to turn light off.

ADDITIONAL CONTROLS AND INDICATORS - CONTINUED

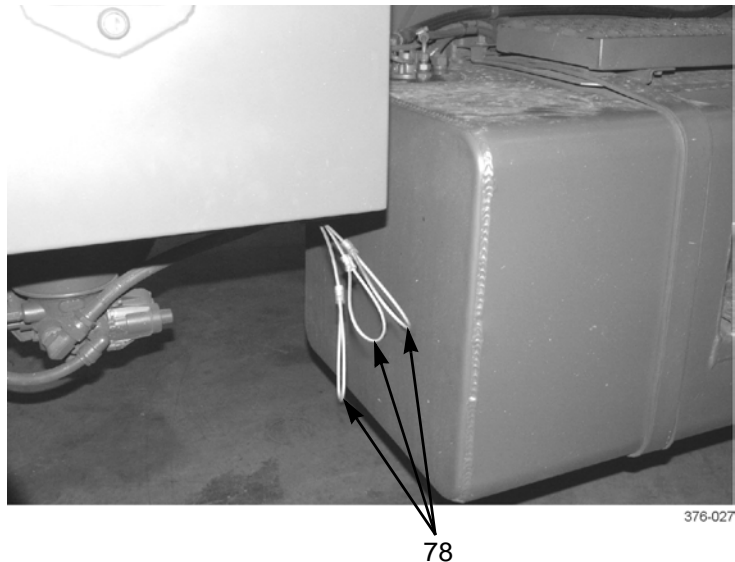

KEY	CONTROL OR INDICATOR	FUNCTION
78	Air Reservoir Drain Cable Pulls	Pull each cable to drain air and condensation from each of three air reservoirs.

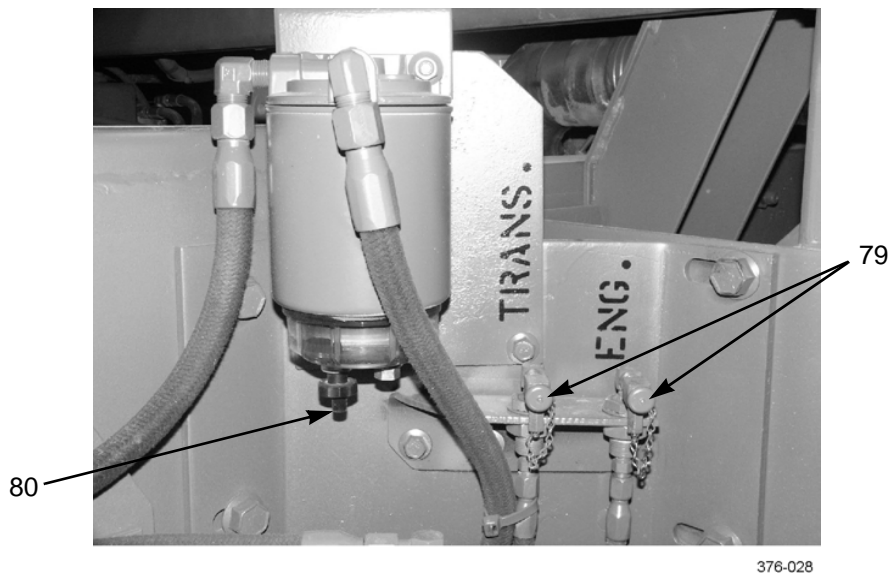

KEY	CONTROL OR INDICATOR	FUNCTION
79	Oil Sampling Valves	Used by Unit Maintenance to obtain engine and transmission samples for AOAP.
80	Fuel/Water Separator Drain Knob	If water or sediment is visible, turn knob clockwise to drain all water from sediment bowl. Turn knob counterclockwise to close.

ADDITIONAL CONTROLS AND INDICATORS - CONTINUED

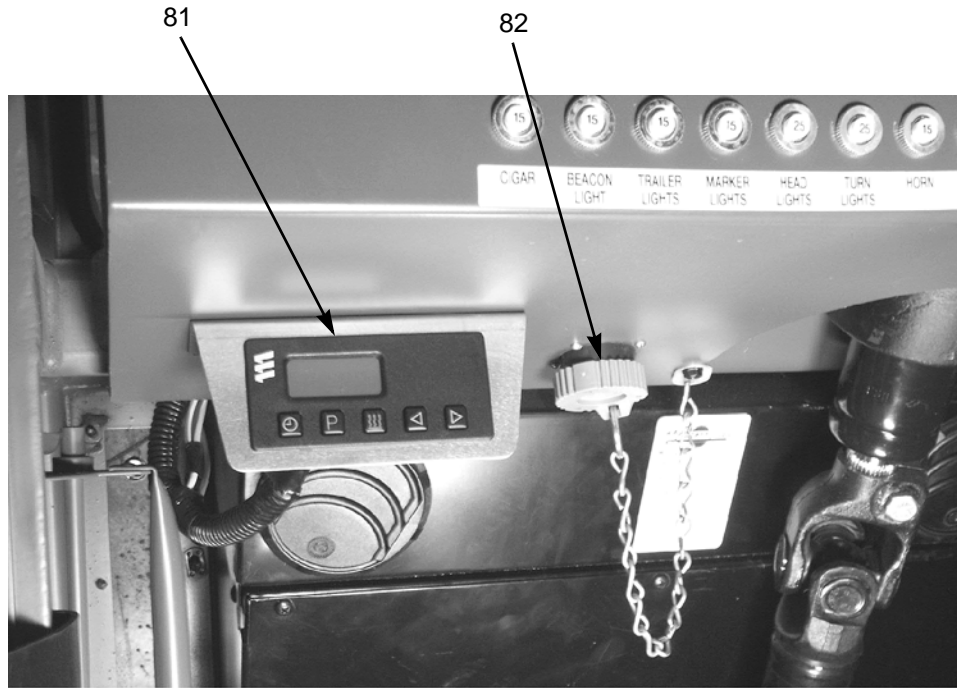

376-032

KEY	CONTROL OR INDICATOR	FUNCTION
81	Arctic Heater 7-Day Timer (If Equipped)	Controls operation of arctic heater and allows for system diagnostics. Refer to <i>Operate in Extreme Cold</i> (WP 0006 00) for a complete description.
82	Diagnostic Connector	Allows connection of diagnostic equipment to troubleshoot the tractor.

END OF WORK PACKAGE

GENERAL**WARNING**

- The standards and laws governing motor vehicles operated on public roads require emission, brake, lighting, and restraint systems that are different from the equipment on this vehicle. This vehicle is NOT designed for use on a public road or highway. Operation on a road or highway may increase the risk of injury or collision and may violate state or federal laws.
- Hearing protection is required when operating this vehicle. Failure to wear hearing protection may result in hearing loss.
- The M878A2 Yard Tractor has a solid mount rear axle suspension and handles differently than a tractor with a sprung suspension. When operating without a trailer, this difference is even more noticeable. Operators must become familiar with the handling of the yard tractor, during training and initial operations, to avoid the potential hazard of vehicle instability and loss of control. Failure to do so may result in serious injury or death to personnel or damage to equipment.

This work package contains instructions for safely operating the M878A2 Yard Tractor under usual conditions. Unusual conditions are defined and described in WP 0006 00.

INITIAL ADJUSTMENTS, DAILY CHECKS, AND SELF-TESTS**NOTE**

Cab side door is to be used for entry or exit from cab only in an emergency. For greatest ease of entry, use steps at battery box to enter cab through the cab rear sliding door.

1. Perform *Before* operation Preventive Maintenance Checks and Services (PMCS) (WP 0012 00).
2. Occupy and adjust seat.
3. Adjust side mirrors and spotter mirrors as needed.

WARNING

Cab side door serves as an emergency exit. It must be unlocked when tractor is operated. Failure to follow this warning may cause serious injury or death to personnel.

4. Close all cab doors. Ensure side door is not locked.

WARNING

Use of seat belts while operating vehicle is mandatory. Fasten belt BEFORE driving. Trying to fasten seat belt while driving creates a hazardous condition. Failure to follow this warning may result in death or injury to personnel.

5. Fasten seat belt.

START ENGINE**NOTE**

- Follow this procedure to start engine at any temperature above -25°F (-32°C). As required, air inlet manifold heater and automatic ether cold start system will function automatically to facilitate cold weather starting.
 - When starting engine in temperatures below -25°F (-32°C), operate arctic heater to preheat engine block (WP 0006 00), then proceed with this procedure.
 - Refer to WP 0004 00 for the location of instrument panel controls and indicators.
1. Ensure parking brake is applied.
 2. Ensure all accessories are off.
 3. Ensure transmission is in N (Neutral).
 4. Insert key into ignition and turn key clockwise to first stop (ON).
 - a. On instrument and warning light cluster, LOW AIR and PARK BRAKE warning lights and LOW AIR warning buzzer will come on. Transmission neutral indicator (NEUTRAL) will also come on. Note that LOW AIR light and buzzer will not come on if air system pressure is above 65 psi (448 kPa).

NOTE

CHK ENG. light will come on and remain on while engine is started. Light will turn off after engine is started and proper oil pressure is achieved. If light fails to come on, DO NOT start engine; notify your supervisor.

- b. On instrument panel, CHK ENG. light, ENG PREHEAT light, and CHECK TRANS light will come on.

NOTE

Air inlet manifold heater system operation is automatic. It is capable of delivering heat for 30 seconds prior to start-up and during cranking of engine. After engine has started, system is capable of delivering heat constantly for seven minutes, or system can cycle heat for 13 minutes. During heating cycle, heat is on for ten seconds and off for ten seconds.

- c. ENG PREHEAT light will remain on for a minimum of two seconds, then turn off, regardless of coolant and air inlet manifold temperatures. If ENG PREHEAT light remains on more than two seconds, wait approximately 30 seconds for light to turn off before cranking engine.

CAUTION

- DO NOT operate starter motor for more than 30 seconds at a time. After 30 seconds, allow starter motor to cool for at least two minutes before attempting to start engine again. Excessive heating of starter motor may result in damage or early starter failure.
- After engine is started, all warning lights should go out in approximately 15 seconds. If warning lights do not go out, shut down engine and investigate cause. Failure to follow this caution may damage engine.
- Engine MUST have adequate oil pressure within 15 seconds after starting. DO NOT leave engine on if high water temperature/low oil pressure (HIGH WATER LOW OIL) light and alarm remain on or oil pressure is not indicated on gauge after 15 seconds. Damage to engine will result.
- If CHK ENG. light fails to turn off after engine has started, shut down engine immediately and notify your supervisor.

START ENGINE - CONTINUED**NOTE**

If engine is not cranking, attempt to start engine by using emergency start switch and capacitor power: Turn ignition switch to ON, hold emergency start switch in up (ON) position, then start engine.

5. Turn and hold ignition switch all the way clockwise and crank engine until it starts or 30 seconds has elapsed. When engine starts, release ignition switch.
 - a. High water temperature/low oil pressure (HIGH WATER LOW OIL) light and alarm, CHK ENG. light, and CHECK TRANS light should go off.
 - b. ENG PREHEAT light will turn back on if engine ECM determines further air intake heating is required.
 - c. STOP ENG. light will come on momentarily, then turn off.
6. If engine does not start, turn ignition off and allow starter motor to cool for two minutes.
7. Repeat steps 4 and 5.

NOTE

- After engine has started, air inlet manifold heater may continue to operate in a continuous and/or intermittent mode. Air inlet heater will turn off when sum of coolant and air inlet temperatures exceeds 127°F (53°C).
 - Due to electrical design of yard tractor, engine may be running without alternator charging the batteries. If volt-meter indicates batteries are not charging, shut down engine and slave start tractor (WP 0006 00).
8. Allow engine to run at low idle (700-750 rpm) to warm engine up to normal operating temperature. In cold weather operating mode, engine ECM will automatically increase engine speed to 1000 rpm to facilitate warm-up.
 9. When pressure in air reservoirs has reached 65 psi (448 kPa), LOW AIR light and warning buzzer will turn off. It is now safe to operate tractor.

OPERATE TRANSMISSION**NOTE**

Refer to WP 0004 00 for a complete description of the transmission range selector.

1. **Transmission Ranges.**
 - a. R (Reverse) is used to back up the vehicle. Vehicle must be brought to a complete stop before shifting from a forward range to R or vice versa. Backup alarm will sound when vehicle is in reverse.
 - b. N (Neutral) is the normal transmission position when vehicle is not in use. Use N to start engine, when idling engine, and for parking.
 - c. When placed in D (Drive), the transmission starts out in 1st gear and automatically progresses to the highest (5th) gear. During slowdown, the transmission automatically downshifts.
 - d. To select a specific forward gear, move transmission range selector lever to 4, 3, 2 or 1 position. The greater the need for engine power or engine braking power, the lower the gear selection should be.
 - (1) Use 4th, 3rd or 2nd gears when road, load or grade conditions make it preferable to use lower gears.
 - (2) Use 1st gear to pull through mud, snow or when going up steep grades or up ramps in RO/RO operations. This gear selection also offers maximum engine braking power for downhill grades or ramps.
 - (3) When conditions improve, return vehicle to D (Drive).

OPERATE TRANSMISSION - CONTINUED**2. Operate Transmission.**

- a. Depress service brake pedal and hold.
- b. Release parking brake.
- c. Release trailer brakes, if towing.
- d. Depress hold override button on side of transmission range selector lever and move lever to desired range. Range selected will display on digital display.
- e. Release brake pedal and begin to move vehicle.
- f. As required, select a specific forward gear using transmission range selector lever.

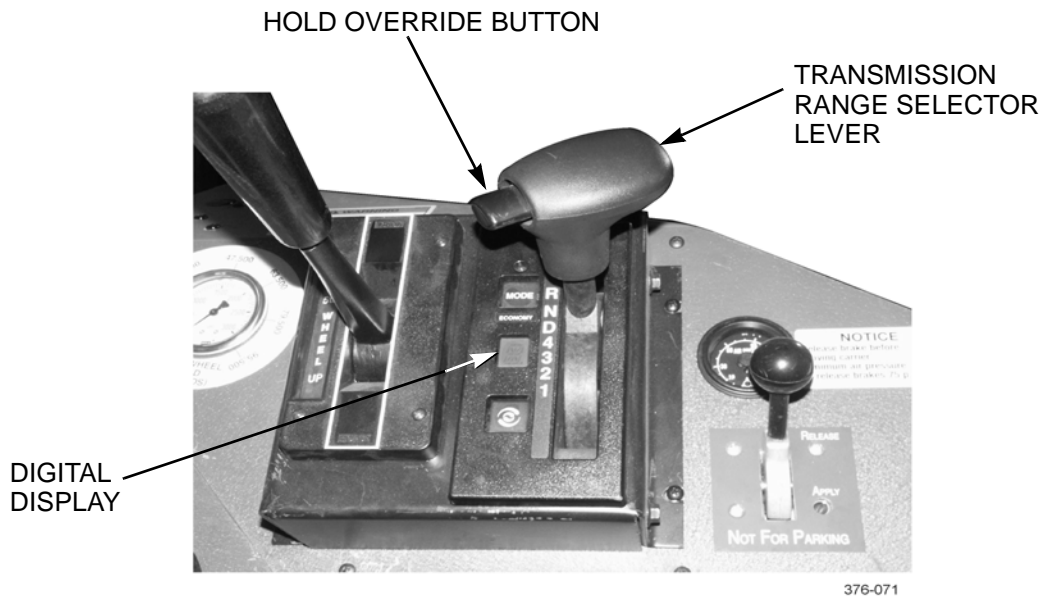
**DRIVING TIPS****WARNING**

- BE ALERT for personnel in area while operating tractor. Always check to ensure area is clear of personnel and obstructions before moving out. Failure to follow this warning may result in serious injury or death to personnel.
- DO NOT allow riders on tractor. Failure to follow this warning may result in serious injury or death to personnel.

NOTE

Refer to *Roll-On/Roll-Off (RO/RO) Procedures* at end of this work package for RO/RO operating instructions.

1. **Check Gauges and Indicators Frequently.** If gauge or indicator shows an abnormal reading or warning light or alarm comes on, bring vehicle to a safe stop, shut down engine, and investigate cause.
2. **Avoid Over Steering.** Become familiar with steering characteristics of vehicle before attempting maneuvers in limited space.

DRIVING TIPS - CONTINUED3. **Avoid Hard Braking.**

- a. Become familiar with the braking characteristics of the tractor with and without a load.
- b. Stop vehicle by applying long even pressure to service brakes. Do not pump brakes.

4. **Drive Efficiently and Economically.**

- a. Drive at safe speeds and avoid sudden stops.
- b. When driving with a load and/or up a ramp, select proper gear to minimize amount of shifting. When pulling out with a load, press accelerator pedal as required to maintain speed.

5. **Drive Safely.****WARNING**

NEVER operate fifth wheel lock control or allow anything to touch it while tractor is in motion. Failure to follow this warning may result in injury or death to personnel.

- a. When moving around yard, turn on appropriate vehicle lights to indicate your presence to others in the area.
 - b. Use a ground guide whenever possible, when backing up tractor and trailer combination.
 - c. Be sure to keep windshields, side windows, and rear door windows clean. Ensure side and spotter mirrors are properly adjusted.
6. **Parking Vehicle.**
- a. Come to a complete stop.
 - b. Depress hold override button on side of transmission range selector lever and place transmission in N (Neutral).
 - c. Pull out on tractor parking brake control (yellow diamond-shaped knob). Be sure that parking brake indicator light on instrument panel comes on.
 - d. If coupled, apply trailer brakes by pulling out on trailer air supply control (red octagonal-shaped knob).

WARNING

If vehicle is left with engine running, vehicle can move suddenly, resulting in serious injury or death to personnel or damage to equipment.

- e. If you must leave vehicle with engine running, block wheels.
7. **Trailer Towing.**

WARNING

Never tow a trailer above the minimum height required for landing gear to clear the ground. Lifting fifth wheel and trailer drastically increases the center of gravity of the trailer and increases the chance of a roll-over. The higher the fifth wheel is raised, the slower the yard tractor should be driven.

- a. Adjust fifth wheel to proper travel height (Refer to *Couple to Trailer*).
- b. When turning or operating in areas of low clearance, always keep in mind the size and tracking characteristics of the trailer being towed.
- c. Keep transmission in a gear range that will provide enough pull.

WARNING

DO NOT exceed 15 mph (24 kph) when towing a trailer. Operating at speeds in excess of 15 mph (24 kph) may lead to loss of vehicle control, resulting in injury or death to personnel.

- d. Go slow enough to be able to stop safely.

DRIVING**NOTE**

Refer to WP 0004 00 for the location of instrument panel controls and indicators.

1. Perform initial adjustments, daily checks, and self-tests.
2. Start engine and allow it to reach operating temperature.
3. Turn on appropriate vehicle lights, as needed.
4. With engine at idle, apply service brakes.
5. Select transmission direction or gear range.
6. Release parking brakes.
7. Depress accelerator pedal and move out gradually.
8. Check gauges and indicators frequently while operating vehicle.

SHUT DOWN ENGINE**CAUTION**

Shutting down engine immediately after operating under a load can result in overheating and accelerated wear of engine components. DO NOT shut down without idling engine for appropriate time period.

NOTE

Refer to WP 0004 00 for the location of instrument panel controls and indicators.

1. With service brakes applied, place transmission in N (Neutral).
2. Apply parking brakes.
3. Allow engine to idle for an appropriate time period:
 - a. If engine has been operating under low loads, idle for 30 seconds before stopping.
 - b. If engine has been operating at high rpm and/or high loads, idle for 3 to 5 minutes.
4. Turn off all accessories.
5. Turn ignition switch counterclockwise to OFF position.
6. Perform *After* operation PMCS (WP 0012 00).

OPERATE FIFTH WHEEL LIFT**WARNING**

- Never tow a trailer above the minimum height required for landing gear to clear the ground. Lifting fifth wheel and trailer drastically increases the center of gravity of the trailer and increases the chance of a rollover. The higher the fifth wheel is raised, the slower the yard tractor should be driven.
- Use extreme caution when raising or lowering fifth wheel, especially when tractor/trailer combination is moving. Raise or lower fifth wheel only enough to achieve adequate clearance for trailer's landing gear and under ride bar. Failure to follow this warning may cause vehicle to roll over, resulting in injury or death to personnel.

OPERATE FIFTH WHEEL LIFT - CONTINUED1. **Raise Fifth Wheel.**

With engine running and transmission in any range, move fifth wheel lift control to UP position.



376-015

2. **Lower Fifth Wheel.**

With engine running and transmission in any range, move fifth wheel lift control lever to DN position.

COUPLE TO TRAILER**NOTE**

Refer to WP 0004 00 for the location of instrument panel and fifth wheel controls and indicators.

1. Begin operation with coupler jaws open. Ensure that manual secondary lock at fifth wheel is disengaged.
2. Back tractor up close to front of trailer. Be sure that throat of fifth wheel is aligned with trailer kingpin. Stop tractor and set tractor parking brakes.
3. Ensure trailer wheels are blocked.
4. Connect service and emergency air lines and electrical line to trailer.
5. Apply trailer parking brakes.
6. Check to see that trailer is at proper coupling height. Front of bolster plate should contact fifth wheel approximately 4-6 in (10-15 cm) behind fifth wheel pivot point.

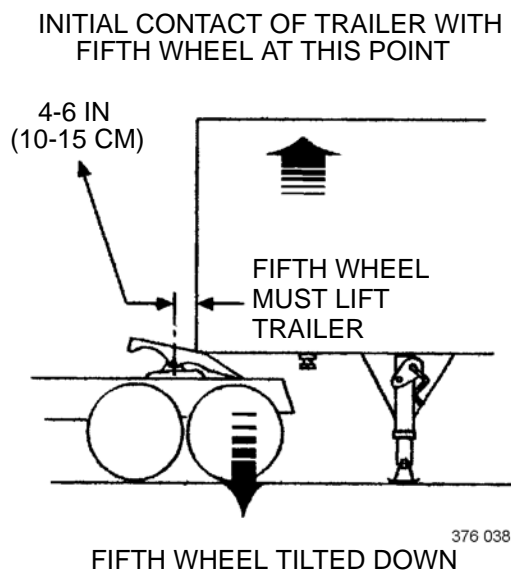

7. If coupling height is not OK, raise or lower fifth wheel (Refer to *Operate Fifth Wheel Lift*) or, if fifth wheel is already fully lowered, raise trailer landing gear, using low gear.

WARNING

Use caution when coupling to trailer. BE ALERT for personnel in area. Ensure hands, arms, and body are clear of potential pinch points. Failure to follow this warning may result in injury or death to personnel.

8. Slowly back tractor under trailer until pivot point of fifth wheel is under trailer. Stop tractor and raise fifth wheel until fifth wheel plate is flush against underside of trailer.
9. Resume backing tractor until it is stopped by positive engagement of kingpin with fifth wheel. Jaws will automatically lock.

COUPLE TO TRAILER - CONTINUED

10. Pull forward to test completeness of coupling as an initial check. Be prepared to stop if coupling is not complete.
11. Apply tractor parking brakes and perform a visual inspection of fifth wheel. Trailer bolster plate must be on fifth wheel and locks closed on kingpin. Yoke shaft at front of fifth wheel plate should be fully retracted.



YOKE SHAFT
RETRACTED

12. Remove blocks from trailer wheels.
13. Release trailer and tractor parking brakes.

WARNING

- Never tow a trailer above the minimum height required for landing gear to clear the ground. Lifting fifth wheel and trailer drastically increases the center of gravity of the trailer and increases the chance of a roll-over. The higher the fifth wheel is raised, the slower the yard tractor should be driven.
- Use extreme caution when raising or lowering fifth wheel, especially when tractor/trailer combination is moving. Raise or lower fifth wheel only enough to achieve adequate clearance for trailer's landing gear and under ride bar. Failure to follow this warning may cause vehicle to roll over, resulting in injury or death to personnel.

CAUTION

Do NOT tow an overloaded trailer. Damage to equipment will result.

14. Check load sensing gauge on instrument panel to ensure trailer weight does not exceed 70,000 lb (31,751 kg) limit. Raise fifth wheel to height necessary for trailer landing gear to clear the ground (Refer to *Operate Fifth Wheel Lift*). ■
15. Move ("spot") trailer.

UNCOUPLE FROM TRAILER**WARNING**

Use caution when uncoupling from trailer. BE ALERT for personnel in area. Ensure hands, arms, and body are clear of potential pinch points. Failure to follow this warning may result in injury or death to personnel.

NOTE

Refer to WP 0004 00 for the location of instrument panel and fifth wheel controls and indicators.

1. Stop tractor/trailer combination.
2. Apply trailer parking brakes.
3. Lower fifth wheel until trailer landing gear touch ground (refer to *Operate Fifth Wheel Lift*) or, if raised, lower trailer landing gear.
4. Block trailer wheels.
5. Disconnect and stow service and emergency air lines and electrical line from trailer.
6. Place fifth wheel lock control to UNLOCKED position.
7. Release tractor parking brake.
8. Slowly pull tractor away from trailer.

OPERATE AIR CONDITIONER**NOTE**

Refer to WP 0004 00 for the location of instrument panel controls and indicators.

1. Start engine.
2. Place temperature control knob to COLD.
3. Place fresh/recirculate air control knob to FRESH (or RECIRC for maximum cooling).
4. Place defroster/heater control knob to HEAT (air to cab).
5. Place AC switch to ON.
6. Place fan switch to desired position (HIGH for maximum cooling).

OPERATE HEATER**NOTE**

Refer to WP 0004 00 for the location of instrument panel controls and indicators.

1. Start engine and bring to normal operating temperature.
2. Place temperature control knob to HOT.
3. Place fresh/recirculate air control knob to FRESH (or RECIRC for maximum heating).
4. Place defroster/heater control knob to HEAT (air to cab).
5. Place fan switch to desired position (HIGH for maximum heating).

OPERATE DEFROSTER**NOTE**

Refer to WP 0004 00 for the location of instrument panel controls and indicators.

1. Start engine.
2. Place temperature control knob to HOT.
3. Place defroster/heater control knob to DEF (air to windshield).
4. Place fan switch to desired position (HIGH for maximum defrosting).

OPERATE VENTILATOR**NOTE**

Refer to WP 0004 00 for the location of instrument panel controls and indicators.

1. Place temperature control knob to COLD.
2. Place fresh/recirculate air control knob to FRESH (outside air).
3. Place defroster/heater control knob to DEF (air to windshield) or HEAT (air to cab).
4. Place fan switch to desired position (HIGH for maximum ventilating).

OPERATE PORTABLE FIRE EXTINGUISHER**WARNING**

Discharging large quantities of dry chemical fire extinguisher in the cab may result in temporary breathing difficulty during and immediately after the discharge event. Discharge fire extinguisher from outside the cab. Ventilate cab thoroughly prior to reentry.

1. Remove fire extinguisher from bracket located behind driver's seat.
2. Hold fire extinguisher upright. Stand back 8 ft (2.4 m) from fire, point nozzle toward base of fire, break seal, and pull safety pin.
3. Squeeze lever, discharging chemical at base of fire. Use a side-to-side motion to spread chemical.
4. After using fire extinguisher, notify Unit Maintenance to have fire extinguisher recharged.

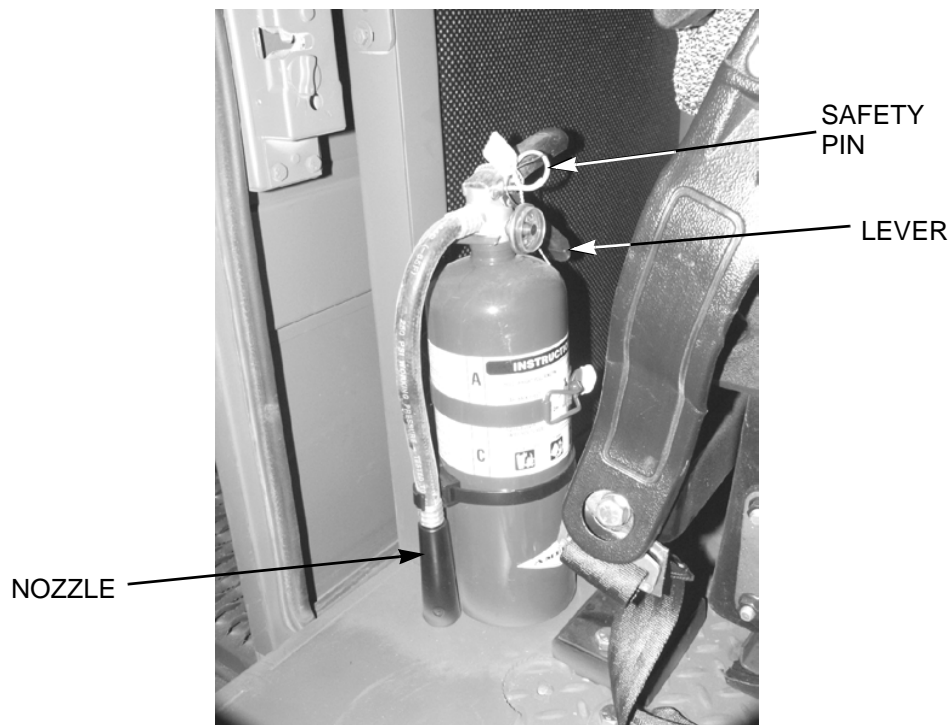

376-023

OPERATE CAB TILT SYSTEM**WARNING**

Ensure that no part of body is under cab while tilting. Stand clear of front and rear of cab while it is being raised. Ensure that tools and supplies are removed from cab and that cab doors are securely closed before tilting cab. Failure to do so may result in serious injury or death to personnel.

CAUTION

DO NOT tilt cab unless there is adequate clearance above and to the front of cab. Cab height will increase as cab is tilted forward. Failure to follow caution may damage cab.

1. Tilt Cab (Powered Operation).

- a. Raise cover to access cab tilt pump.
- b. Move cab tilt lever toward rear of vehicle, to raise (tilt) position.
- c. Push and hold power button until cab has tilted to desired position.
- d. Move cab tilt lever toward front of vehicle, to return (lower) position. Cab will drop slightly as safety prop locks into position.
- e. Move cab tilt lever to raise (tilt) position. Lever must remain in raise (tilt) position for as long as cab is supported by safety prop.

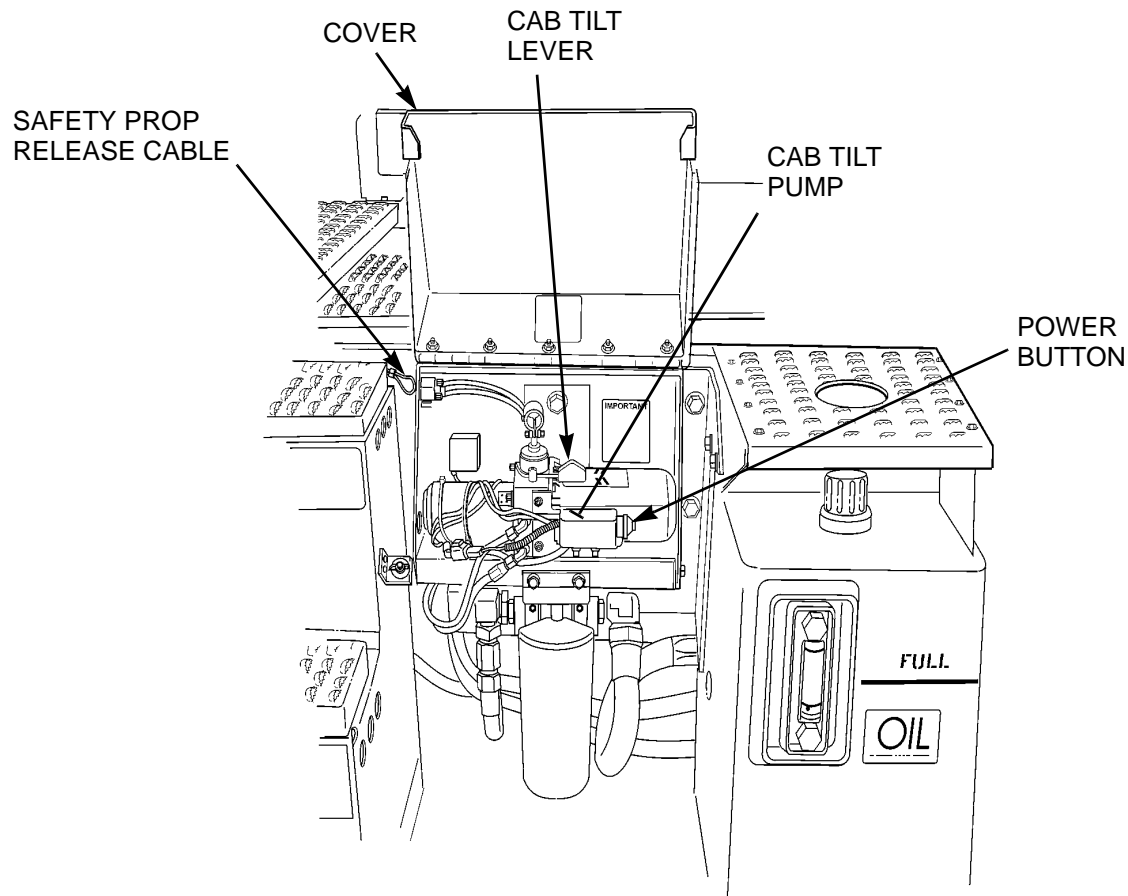

376-003

OPERATE CAB TILT SYSTEM - CONTINUED**WARNING**

Always check that cab tilt safety prop is properly engaged before working under cab. Cab could fall and cause serious injury or death.

- f. Before working under cab, check that safety prop is secure. Safety prop latching pin must be engaged in notch of safety prop.

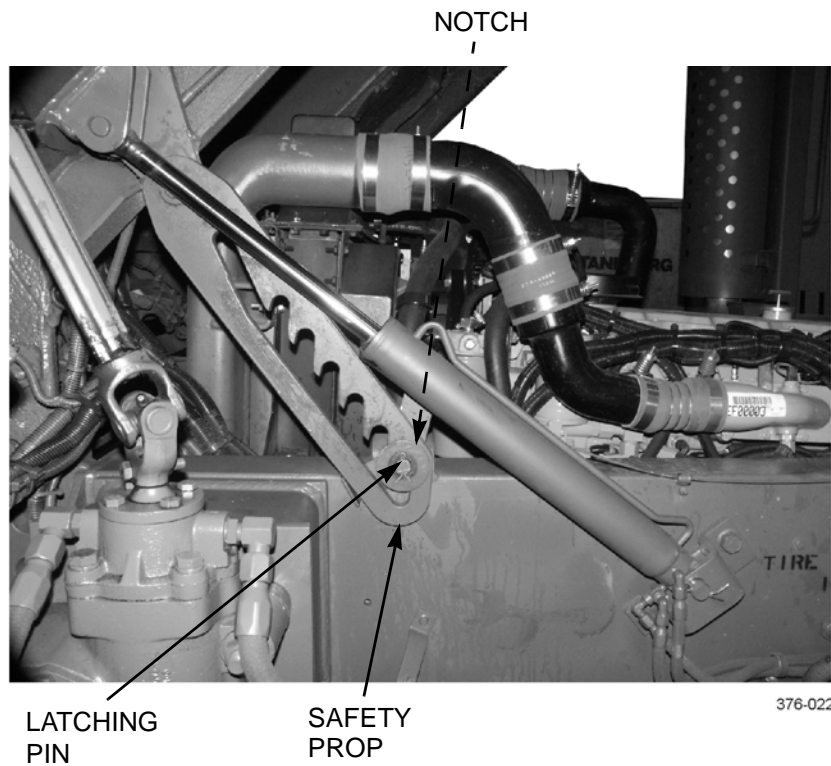

OPERATE CAB TILT SYSTEM - CONTINUED**2. Lower Cab (Powered Operation).**

- a. Push power button to lift cab clear of notch in safety prop.

CAUTION

DO NOT power cab down. Powering cab down puts undue stress on cab. Damage to cab could result.

- b. Pull and hold safety prop release cable while moving cab tilt lever toward front of vehicle, to return (lower) position. Allow cab to lower by gravity ONLY.
- c. Continue to pull on release cable until cable resistance is felt. Release cable.

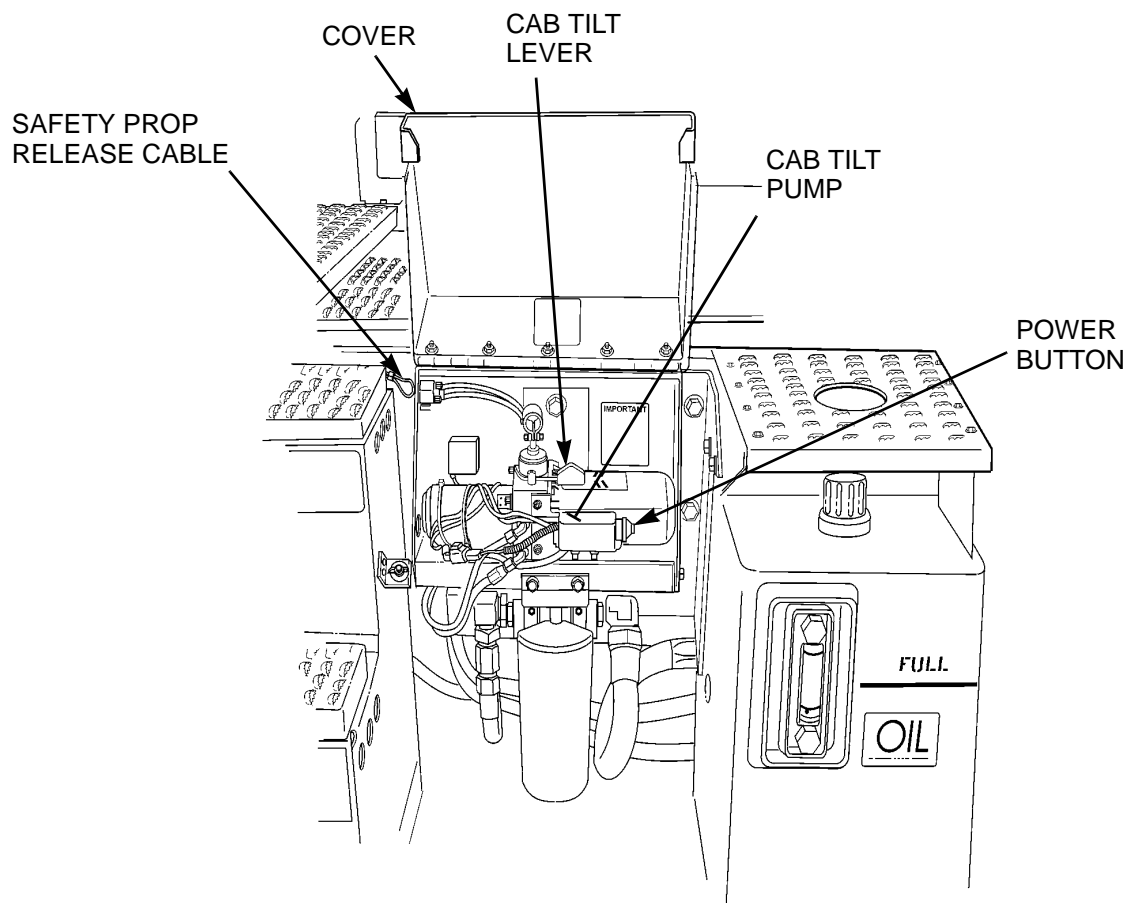

376-003

OPERATE CAB TILT SYSTEM - CONTINUED**WARNING**

Ensure cab latch fully engages after lowering cab. If cab latch is not engaged, cab could tilt while vehicle is in motion. Failure to follow this warning may result in injury or death to personnel.

- d. After cab has lowered onto cab latch, check lock indicator plunger on side of latch. If plunger is pushed in, cab is latched.

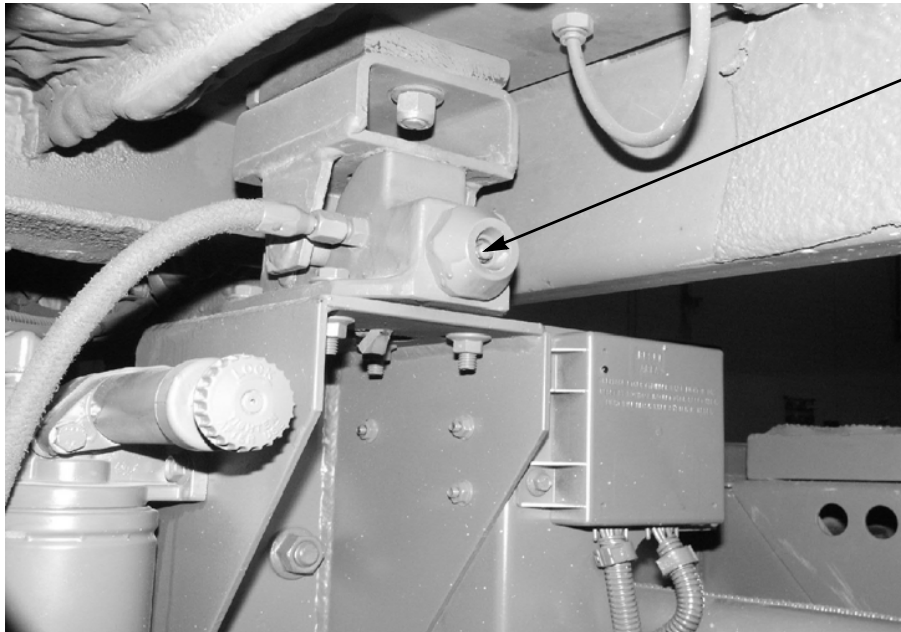

376-021

- e. Keep cab tilt lever in return (lower) position for as long as cab is lowered.

OPERATE CAB TILT SYSTEM - CONTINUED3. **Tilt Cab (Manual Operation).**

- a. Remove handle for manual jack operation from stowage behind driver's seat.
- b. Raise cover to access cab tilt pump.
- c. Move cab tilt lever toward rear of vehicle, to raise (tilt) position.
- d. Place handle into manual jack. Jack cab up manually to desired position.
- e. Move cab tilt lever toward front of vehicle, to return (lower) position. Cab will drop slightly as safety prop locks into position.
- f. Move cab tilt lever to raise (tilt) position.

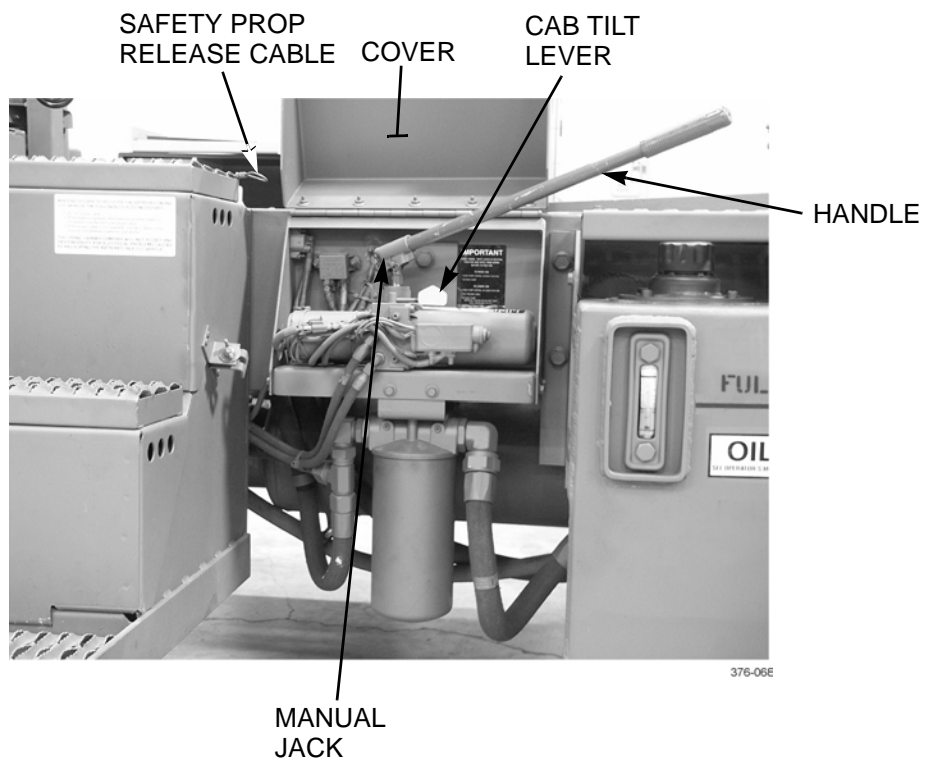

OPERATE CAB TILT SYSTEM - CONTINUED



WARNING

Always check that cab tilt safety prop is properly engaged before working under cab. Cab could fall and cause serious injury or death.

- g. Before working under cab, check that safety prop is secure. Safety prop latching pin must be engaged in notch of safety prop.

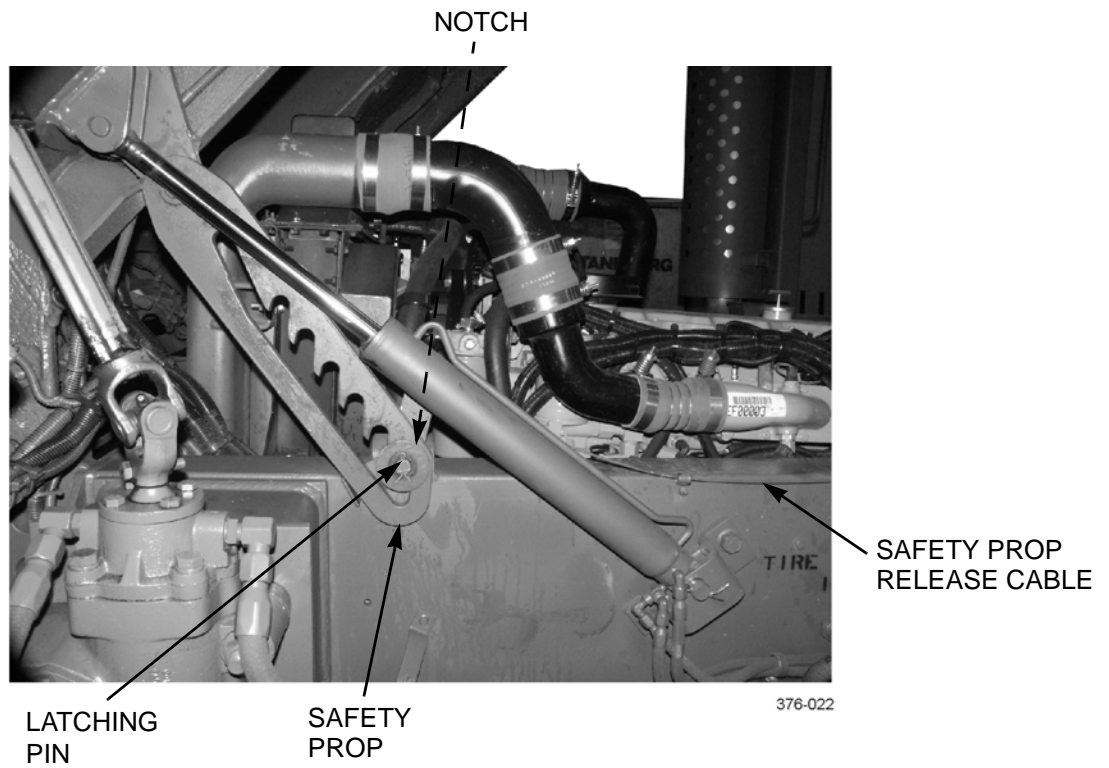

OPERATE CAB TILT SYSTEM - CONTINUED4. **Lower Cab (Manual Operation).**

- a. Jack cab up manually to lift cab clear of notch in safety prop.
- b. Pull and hold safety prop release cable while moving cab tilt lever toward front of vehicle, to return (lower) position. Allow gravity to lower cab.
- c. Continue to pull on release cable until cable resistance is felt. Release cable.

WARNING

Ensure cab latch fully engages after lowering cab. If cab latch is not engaged, cab could tilt while vehicle is in motion. Failure to follow this warning may result in injury or death to personnel.

- d. After cab has lowered onto cab latch, check lock indicator plunger on side of cab latch. If plunger is pushed in, cab is properly latched.

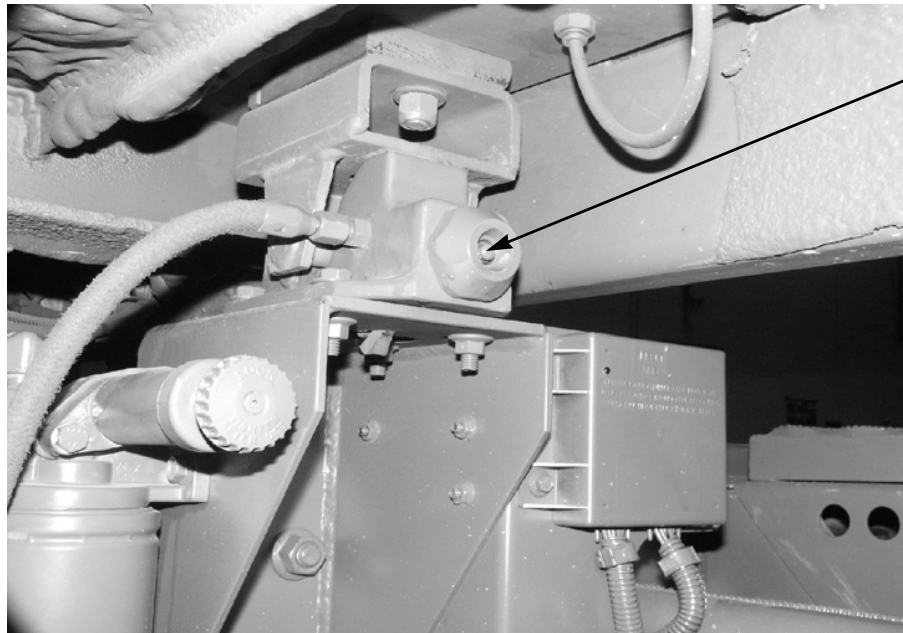

PLUNGER IN =
LATCHED

376-021

- e. Keep cab tilt lever in return (lower) position for as long as cab is lowered.
- f. Return manual jack handle to stowage location behind driver's seat in cab.

INFLATE TIRE

1. Remove pneumatic tire inflator-gage (WP 0018 00) from stowage compartment.

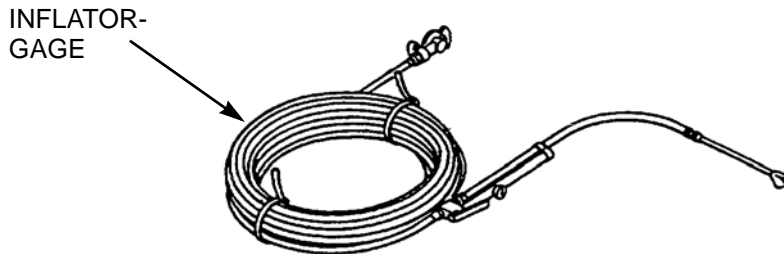

376-079

2. Remove dummy coupling and connect inflator-gage to emergency gladhand (red) at rear of vehicle.
3. Start engine (WP 0005 00). Push in trailer air supply control on right side of instrument panel.
4. Remove valve stem cap and connect inflator-gage to valve stem.



FRONT

376-073

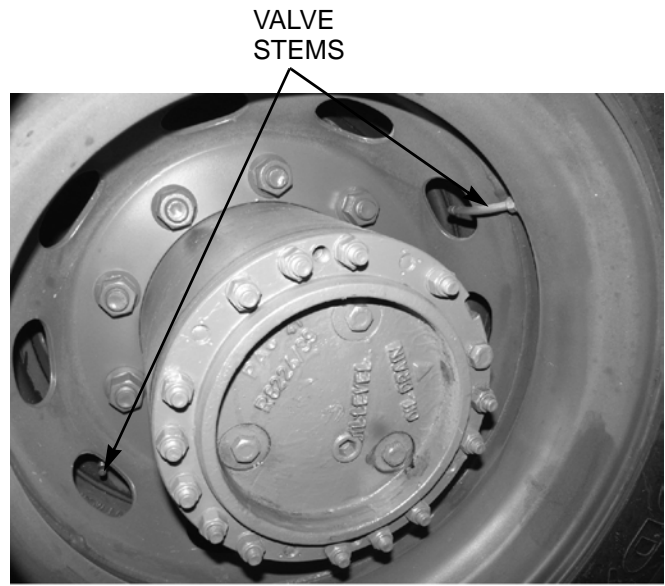

REAR

376-11E

NOTE

- Due to speed limitation of vehicle and its load capability, tire manufacturer has authorized a tire inflation of 120 psi (827 kPa).
- If inflating rear dual wheels, add air at both valve stems, located approximately 180 degrees apart from each other.

5. Add air until 120 psi (827 kPa) pressure is reached.
6. Remove inflator-gage from valve stem and install valve stem cap.
7. Pull out trailer air supply control. Shut down engine (WP 0005 00).

INFLATE TIRE - CONTINUED

8. Disconnect inflator-gage from emergency gladhand and return to stowage compartment. Reinstall dummy coupling on emergency gladhand.

ROLL-ON/ROLL-OFF (RO/RO) PROCEDURES**NOTE**

Refer to FM 55-17, *Cargo Specialists' Handbook* for further information on RO/RO procedures.

1. Introduction.

- a. The yard tractor is used to load and unload trailers on ships during RO/RO operations.
- b. At all times, the yard tractor's movements are under the overall control of the RO/RO vehicle director. Loading and unloading is accomplished by following the vehicle director's traffic control plan.
- c. Trailers are loaded by moving them from dockside to the appropriate level and hold on board ship. Once stowed, crews secure trailers for shipping by lashing, shoring, blocking or bracing, as appropriate. Unloading is accomplished by moving trailers from on board ship to dockside.
- d. In order to accomplish RO/RO, the yard tractor must operate up and down ramps on the ship. The grade of the ramps will vary, depending on the tide and the weight of the ship at the time of loading or unloading. Under the worst case scenario, the ramp could have a 12-15 degree grade.
- e. Ground guide assistance is mandatory when the yard tractor is operating on ramps. One ground guide must be stationed at the bottom of the ramp and another at the top. The operator and ground guides communicate with each other using hand signals.
- f. The key to safe and timely RO/RO operations is teamwork between the yard tractor operator and the ground guides. The driver cannot see most of the interference problems that arise between the trailer being towed and the ramp. The ground guides can see these situations. They tell the operator when to raise or lower the fifth wheel in order to eliminate the interference.

2. RO/RO Regulations.**WARNING**

Safe RO/RO operation depends on strict adherence to RO/RO regulations. Failure to do so may result in injury or death to personnel or damage to equipment.

- a. Only qualified and screened operators are permitted to drive the yard tractor in RO/RO operations.

**WARNING**

Operation within the confines of a ship during RO/RO operation requires hearing protection. Failure to wear hearing protection may result in hearing loss.

- b. All personnel working in vehicle operating areas **MUST** wear hearing protection.
- c. **DO NOT** move tractor about the ship without a ground guide present.

ROLL-ON/ROLL-OFF (RO/RO) PROCEDURES - CONTINUED

- d. Before moving any trailer, ensure that trailer's cargo has been properly secured to prevent movement and shifting of load.
 - e. If moving a fuel tanker, ensure that fuel tanker is clear for shipment and is safe to load on board ship.
 - f. Do not start yard tractor engine until directed to do so by supervisor. Before moving out, test brakes.
 - g. Operate vehicle with lights on.
 - h. Only one vehicle may transit a ramp at any time.
 - i. Do not leave vehicle engine running unattended.
 - j. Do not exceed 5 mi/hour (8 km/h) while moving about the ship.
3. **Operating Up Ramp.**

WARNING

Use 1st gear ONLY and exercise extreme caution when driving up ramp. Operator must follow instructions from ground guides at all times. Proceed slowly and raise and lower fifth wheel as required so that trailer landing gear and under ride bar at rear of trailer do not contact ramp. Failure to follow this warning may result in an accident, causing damage to equipment or injury or death to personnel.

NOTE

Raise and lower fifth wheel in accordance with instructions in *Operate Fifth Wheel Lift* on page 0005 00-6.

- a. Approach ramp with fifth wheel raised so that landing gear of trailer is 6-8 in (15-20 cm) off the ground.
- b. Shift transmission into 1st gear before starting up ramp.



LANDING GEAR HAS
6-8 IN (15-20 CM) CLEARANCE

376-331

ROLL-ON/ROLL-OFF (RO/RO) PROCEDURES - CONTINUED

- c. Proceed up ramp slowly.
- d. Lower fifth wheel as required while going up ramp to allow clearance for under ride bar at rear of trailer.



WARNING

If tractor and fully-loaded trailer combination is stopped while negotiating crest of ramp, then engine is accelerated to resume forward movement, front end of tractor may lift off the ground. To prevent this, do NOT accelerate engine suddenly. Accelerate engine slowly. Failure to follow this warning may cause loss of vehicle control and injury or death to personnel.

- e. After tractor clears crest of ramp, raise fifth wheel to allow landing gear of trailer to clear crest of ramp.

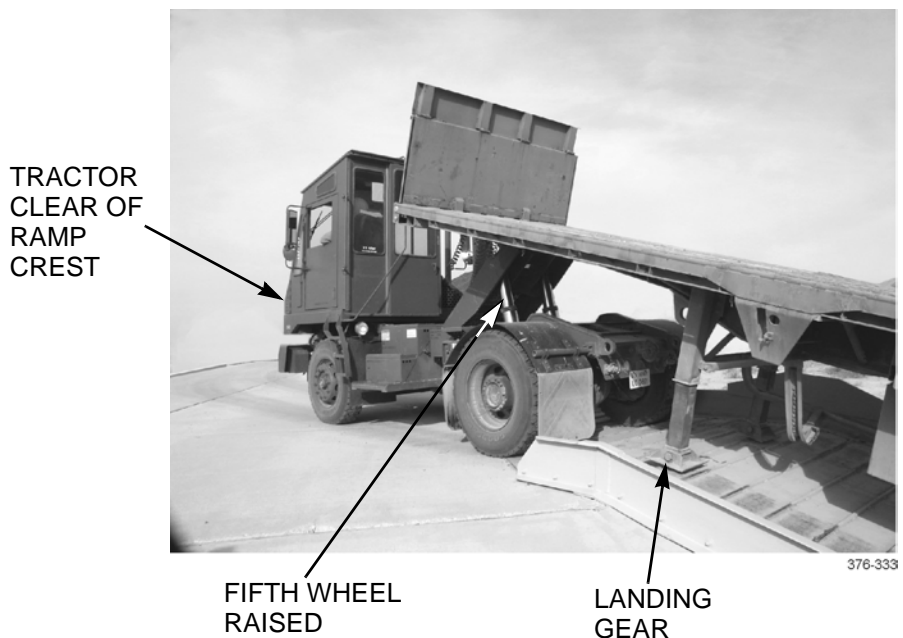

ROLL-ON/ROLL-OFF (RO/RO) PROCEDURES - CONTINUED

- f. When first axle of trailer reaches crest, lower fifth wheel until landing gear has adequate clearance.

4. Operating Down Ramp.**WARNING**

Use 1st gear ONLY and exercise extreme caution when driving down ramp. Operator must follow instructions from ground guides at all times. Proceed slowly and raise and lower fifth wheel as required so that trailer landing gear and under ride bar at rear of trailer do not contact ramp. Failure to follow this warning may result in an accident, causing damage to equipment or injury or death to personnel.

NOTE

Raise and lower fifth wheel in accordance with instructions in *Operate Fifth Wheel Lift* on page 0005 00-6.

- a. Raise fifth wheel as tractor approaches top of ramp to allow landing gear to clear ramp crest.
b. Shift transmission into 1st gear before starting down ramp.



ROLL-ON/ROLL-OFF (RO/RO) PROCEDURES - CONTINUED

- c. When first axle of trailer reaches crest of ramp, lower fifth wheel as required.

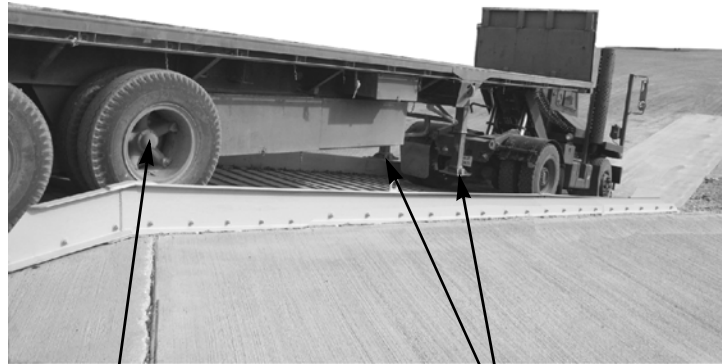

376-335

FIRST AXLE
CLEAR OF
RAMP CREST

LANDING
GEAR

CAUTION

Use caution when lowering fifth wheel. If fifth wheel is lowered too low, front of trailer may come in contact with tractor. Failure to follow this caution may cause damage to trailer or tractor.

- d. When first axle of trailer reaches bottom of ramp, lower fifth wheel further so that under ride bar at rear of trailer clears ramp.
- e. Drive away slowly from ramp, while raising fifth wheel as required to achieve adequate landing gear clearance.

END OF WORK PACKAGE

GENERAL**WARNING**

This vehicle has been designed to operate safely and efficiently within the limits specified in this TM. Operation beyond these limits is prohibited in accordance with AR 70-1.

1. This work package contains instructions for safely operating the M878A2 Yard Tractor under unusual conditions. In addition to normal preventive maintenance, special care must be taken to keep tractor operational in extreme temperatures and other environmental conditions.
2. Refer to FM 21-300 and FM 21-305 for additional information.

SLAVE START TRACTOR**WARNING**

- When slave starting tractor, use NATO slave cable that DOES NOT have loose or missing insulation.
- DO NOT proceed if suitable cable is not available.
- DO NOT use civilian-type jumper cables.

CAUTION

- DO NOT allow “live” and “dead” vehicles to come in contact with each other during slave starting. Failure to follow this caution may cause electrical system damage.
- Under no circumstances can the tractor be started by being towed or pushed. Failure to follow this caution will cause damage to transmission.
- DO NOT operate starter motor for more than 30 seconds at a time. After 30 seconds, allow starter motor to cool for at least two minutes before attempting to start engine again. Excessive heating of starter motor may result in damage or premature starter failure.

NOTE

If vehicle other than another M878A2 is used to slave start tractor, refer to Operator’s Manual for that vehicle for any special slave starting procedures.

SLAVE START TRACTOR - CONTINUED

1. Ensure battery disconnect switch is in OFF position on "dead" vehicle.
2. Connect NATO slave cable to receptacle on "dead" vehicle.

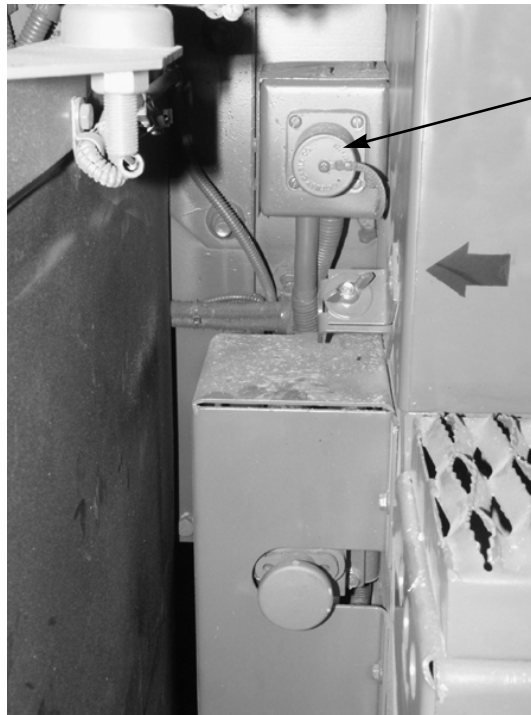

NATO SLAVE
RECEPTACLE

376-008

3. Connect other end of NATO slave cable to receptacle on "live" vehicle.
4. Start engine of "live" vehicle and run at 1000 rpm.
5. Place battery disconnect switch and ignition switch on "dead" vehicle to ON position.
6. Allow "live" vehicle to run for 2-3 minutes to charge capacitor(s) on "dead" vehicle.
7. Place ignition switch and then battery disconnect switch on "dead" vehicle to OFF position.
8. Shut down "live" vehicle and disconnect NATO slave cable from both vehicles.
9. Place battery disconnect switch on "dead" vehicle in ON position.
10. Turn ignition switch to START position and start vehicle.

NOTE

With engine at idle speed, check instrument panel voltmeter to ensure voltmeter indicator is in GREEN area.
If voltmeter indicator is NOT in GREEN area, shut down engine and continue slave starting steps.

11. Connect NATO slave cable to receptacle on "dead" vehicle.
12. Connect other end of NATO slave cable to receptacle on "live" vehicle.
13. Start engine of "live" vehicle and run at 1000 rpm.
14. Place battery disconnect switch and ignition switch on "dead" vehicle to ON position.
15. Allow "live" vehicle to run for 15 minutes to charge vehicle batteries and capacitor(s).
16. Place ignition switch and then battery disconnect switch on "dead" vehicle to OFF position.

SLAVE START TRACTOR - CONTINUED

17. Shut down "live" vehicle and disconnect NATO slave cable from both vehicles.
18. Place battery disconnect switch on "dead" vehicle in ON position.
19. Turn ignition switch to START position and start vehicle.

NOTE

With engine at idle speed, check instrument panel voltmeter to ensure voltmeter indicator is in GREEN area. If voltmeter indicator is NOT in GREEN area, shut down engine and perform troubleshooting (WP 0009 00).

TOWING TRACTOR**1. General.**

- a. Notify Unit Maintenance to send recovery vehicle. Tools will also be required to remove propshaft, if towing with all wheels or rear wheels on the ground.
- b. Refer to FM 21-305 for general guidelines on vehicle recovery and use of warning kits and signals.

CAUTION

Propshaft must be removed before towing tractor with all wheels or rear wheels on the ground. Failure to follow this caution may result in transmission damage.

- c. When towing tractor with all wheels or rear wheels on ground, have Unit Maintenance remove propshaft.
 - d. When rear axle of tractor being towed is lifted off the ground, secure steering wheel to maintain straight-ahead position.
- 2. Towing Procedures.**

WARNING

- DO NOT lift or tow vehicle by attaching chains directly to the bumper. Failure to follow this warning may result in injury to personnel or damage to equipment.
- Brakes will be released when air is applied to a disabled vehicle. DO NOT connect air lines to a disabled vehicle without first blocking wheels and connecting tow bar between vehicles. Failure to follow this warning could result in death or injury to personnel and damage to equipment.

TOWING TRACTOR - CONTINUED

- a. Block wheels of disabled tractor.
- b. Install medium duty tow bar between towing vehicle and tractor towing eyes. Ensure tow bar is long enough to allow complete turning radius.

NOTE

As required, tractor may be towed without intervehicular air lines connected. Cage brakes (Refer to *Cage and Uncage Brakes* in this work package) before attempting to tow.

- c. Connect BII air lines between disabled tractor and towing vehicle.
- d. Release parking brakes and turn appropriate lights on, to include strobe warning light of disabled tractor.

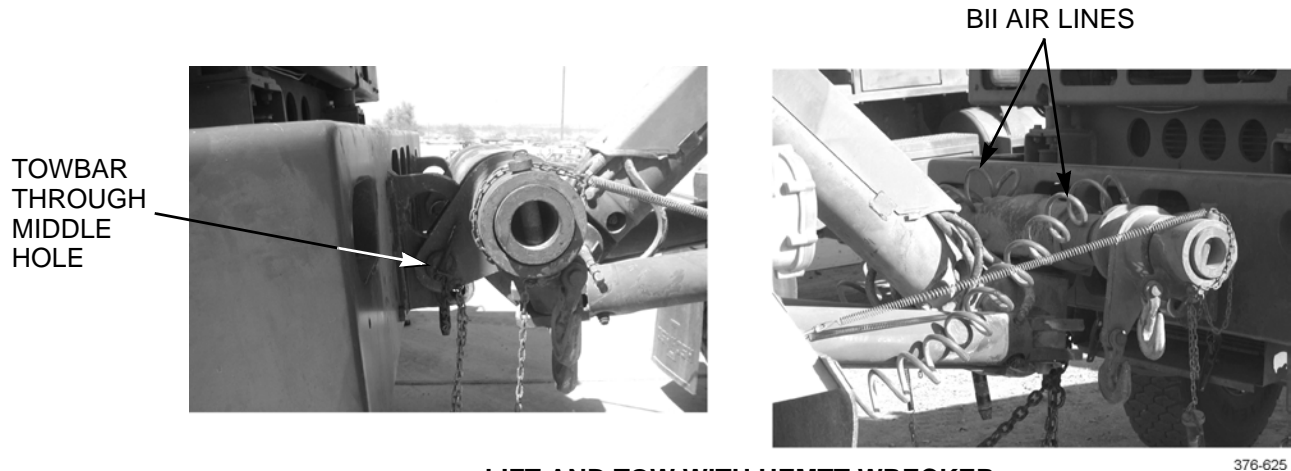

LIFT AND TOW WITH HEMTT WRECKER

376-625

CAGE AND UNCAGE BRAKES**NOTE**

Assistance from Unit Maintenance is required to cage or uncage brakes.

1. **Cage Brakes.** In the event of an air pressure loss, spring brakes on the rear axle will apply the brakes. If the vehicle must be towed and there is not enough air system pressure to compress the power spring in the spring brake chambers to release the brakes, compress them manually. Each vehicle has two spring brakes.

WARNING

- Brake chamber contains spring under great pressure. To prevent personnel injury, avoid working directly behind chamber. If caging bolt will not engage properly, spring may be broken.
 - DO NOT remove clamp ring around spring brake chamber. It is under tension and can cause personnel injury if released.
 - When caging brakes, block wheels to keep tractor from moving when brakes are released. Failure to follow this warning may result in death or injury to personnel or damage to equipment.
- a. Block wheels.
 - b. Remove cap (3).
 - c. Remove nut (4), washer (5), and release stud (2) from stowage pocket (1).

CAGE AND UNCAGE BRAKES - CONTINUED

- d. Insert cross-pin end of release stud (2) into opening where cap (3) was removed.
 - e. To engage cross-pin, rotate release stud (2) ¼ turn clockwise until cross-pin end goes into slot inside of spring chamber (6). Cross-pin is properly engaged if it does not pull out or rotate when pulled.
 - f. Install washer (5) and nut (4) on release stud (2). Thread nut all the way to chamber.
 - g. Install cap (3).
 - h. Tighten nut (4) with a hand wrench until spring is fully caged and brakes are fully released.
 - i. Repeat steps b-h to cage spring on other rear airbrake chamber.
2. **Uncage Brakes.**
- a. Ensure wheels are blocked.
 - b. Remove cap (3).
 - c. Remove nut (4) and washer (5) from release stud (2).
 - d. Turn release stud (2) to left ¼ turn and remove release stud from spring chamber (6).
 - e. Insert release stud (2) into stowage pocket (1) and install washer (5) and nut (4) on release stud.
 - f. Reinstall cap (3).
 - g. Repeat steps b-f to uncage spring on other rear airbrake chamber.

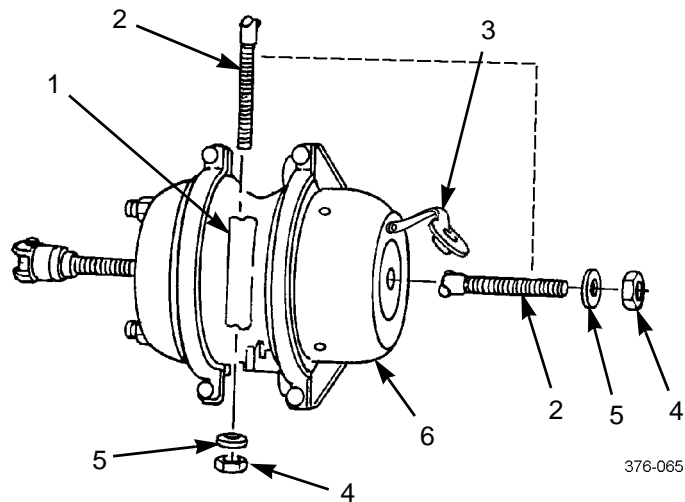

OPERATE IN EXTREME COLD1. **General.****NOTE**

Refer to FM 9-207 for additional information.

- a. Extreme cold causes many problems:
 - (1) Lubricants thicken or congeal.
 - (2) Batteries may freeze or lose their electrical efficiency.
 - (3) Fuel may not readily atomize for combustion.
 - (4) Various materials become hard, brittle, and easily damaged.
 - (5) Cooling system requires adequate protection from extreme cold.
 - (6) Fuels, lubricants, and antifreeze compounds require special storage, handling, and use.
- b. A 50/50 mixture of antifreeze (Item 1, WP 0019 00) and water is used in cooling system to provide freeze protection down to -34°F (-37°C). Below -34°F (-37°C), use a 60/40 mixture of antifreeze and water.
- c. An auxiliary arctic heater kit is provided as an AAL item (WP 0018 00) for all vehicles assigned to arctic regions [below -25°F (-32°C)], to protect vehicle systems from freeze damage. The arctic heater enables easier starting by providing engine block preheating. The system also provides for heating of transmission fluid. Refer to subparagraphs 2 and 3 for operation of arctic heater.
- d. When starting out:
 - (1) Be careful when you first start your vehicle. Allow engine time to warm up so that it idles smoothly.
 - (2) Start driving very slowly for about 100 yards (91.4 m). Be alert for signs that tires may have flat spots or that one or more brakeshoes may be frozen and require preheating. Notify Unit Maintenance as required.
- e. Parking.
 - (1) If vehicle will be parked for a short period, park in a sheltered area out of wind. If shelter is not available, park vehicle so it does not face into the wind.
 - (2) If vehicle will be parked for a long shutdown period, try to park on high ground and use planks or brush to make a raised and relatively dry surface. Keep tires out of snow, water, ice, and mud, if possible.
 - (3) Clean snow, ice, and mud from vehicle as soon as possible after shutdown.
 - (4) If vehicle will be parked for a long period of time, have Unit Maintenance remove and store batteries. Fill fuel tank to guard against condensation and drain any accumulated water from air reservoirs and fuel filter/water separator.
 - (5) Ensure tires are properly inflated.
 - (6) Have Unit Maintenance check and service cooling system to ensure tractor is adequately protected against extreme cold. Ensure transmission is in N (Neutral) position and vehicle tires are blocked.

OPERATE IN EXTREME COLD - CONTINUED

2. Arctic Heater Controls (If Equipped).

- a. A 7-day timer, mounted under the left side of the instrument panel, operates the arctic heater.
- b. The timer also provides the capability for troubleshooting diagnostics. It automatically displays any heater fault codes in three-digit form.

NOTE

The heater will not function until the timer is programmed.

- c. The timer allows for pre-selection of turn-on time, up to seven (7) days in advance, as well as varying run times. There is also an on/off switch for manual operation.
- d. The following illustration shows the timer and its controls:

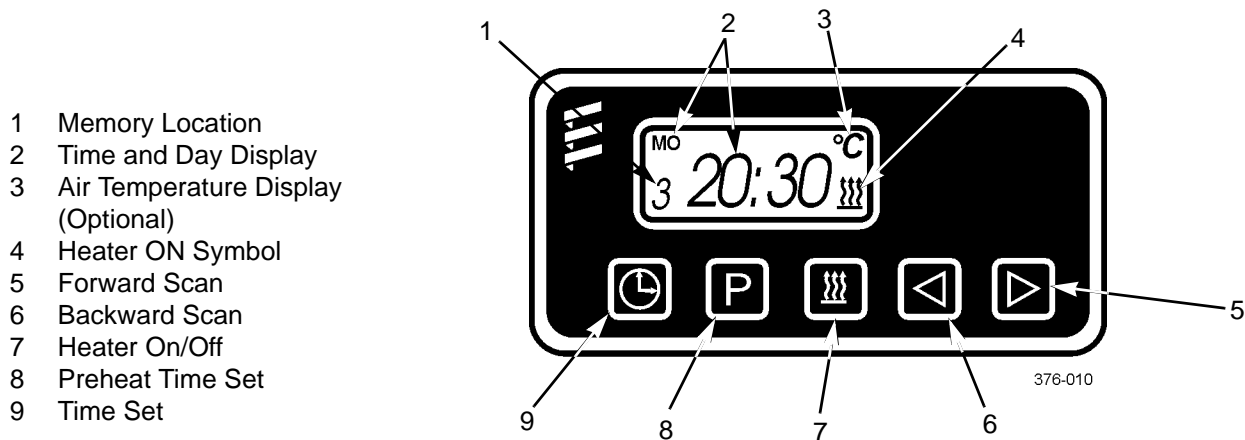

****NOTE** When vehicle lights are on, timer display back-light will also turn on.

3. Operate Arctic Heater (If Equipped).



WARNING

Arctic heater must not be operated in garages or enclosed areas due to the dangers of carbon monoxide poisoning. Failure to follow this warning could result in death or injury to personnel.

NOTE

Set vehicle heater to maximum temperature setting and heater/AC fan to LOW setting before operating the heater.

OPERATE IN EXTREME COLD - CONTINUED**a. Setting Time and Day.****NOTE**

Time and day display will turn off 15 seconds after display has been set.

- (1) Press time set button (9). 12:00 will begin to flash.
- (2) Using forward or backward scan (5 or 6), set correct time of day (24-hour clock). When time stops flashing, time has been stored.
- (3) The day of the week will now begin to flash.
- (4) Using forward or backward scan (5 or 6), set correct day of the week. When weekday stops flashing, weekday has been stored.
- (5) To change the time or day after storing, press and hold time set button (9) until time and day display begins to flash. Repeat steps 2 through 4.

b. Using Timer (Vehicle Ignition Off).

- (1) Press heater on/off button (7).
- (2) Heater ON symbol (4) and operation countdown timer will appear on the display. Heater will begin to preheat. Preheat cycle will run continuously unless preheat cycle time is set for a specific value.
- (3) At end of preheat cycle, timer will turn heater off. Heater will complete a cool down cycle, then turn itself off.

c. Adjusting Preheat Time.**NOTE**

- Running time for heater may be reset once or permanently, as desired.
 - To adjust preheat time once, perform steps 1 and 2.
 - To adjust preheat time permanently, perform steps 3 and 4.
- (1) Press Heater on/off button (7). Heater ON symbol (4) and pre-selected run time (120) will appear on the display.
 - (2) Using forward or backward scan (5 or 6), adjust desired run time.
 - (3) Press and hold backward scan button (6) for approximately three (3) seconds, until display lights up and flashes. Release button.
 - (4) Using forward or backward scan (5 or 6), set new fixed preheat time. When display goes off, new preset time is set.

d. Using Heater Manually.**NOTE**

- If heater fails to start first time, it will automatically attempt a second start. If unsuccessful the heater will shut down completely.
 - During operation, heater senses input voltage from batteries. If voltage drops to 20V or rises above 30V, heater will automatically shut down.
- (1) Press heater on/off button (7). Heater ON symbol (4) will appear in display next to time and day.
 - (2) Change run time by pressing forward or backward scan (5 or 6).
 - (3) Heater may be turned off by pressing heater on/off button (7).

OPERATE IN EXTREME COLD - CONTINUED

e. Setting Preheat Start Times into Memory.

- (1) Press preheat time set button (P) (8) until desired memory location (1) is displayed (three memory locations are available).

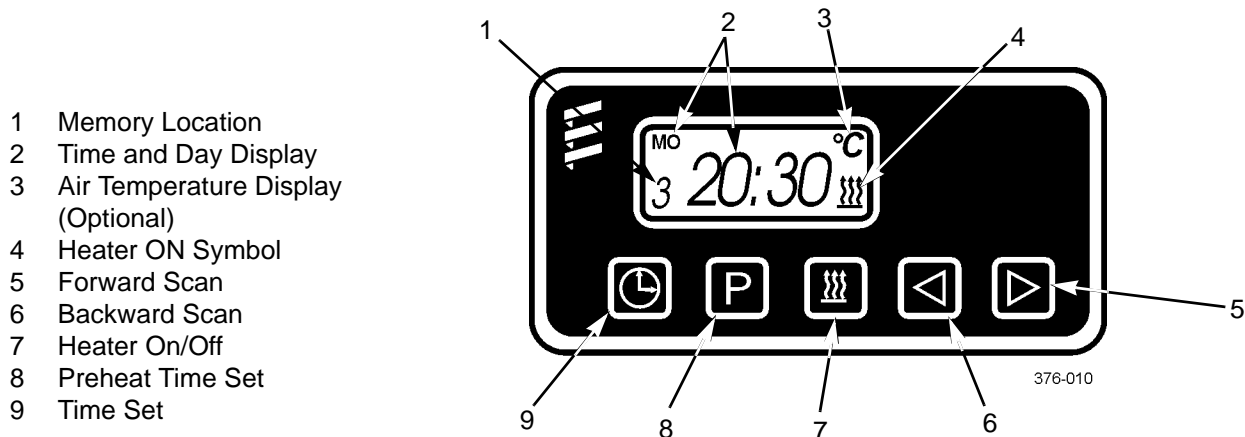

****NOTE** When vehicle lights are on, timer display backlight will also turn on.

- (2) Using forward or backward scan (5 or 6), set desired preheat start time of day. When time stops flashing, time of day is set.
- (3) Using forward or backward scan (5 or 6), set desired day of week. When day of week stops flashing, day is set.

f. Operating Heater Using Preset Start Times.

- (1) Press preheat time set button (P) (8) until desired memory location (1) is displayed. Heater will automatically start at time and day displayed.
- (2) The time and day display will go off in 15 seconds, but the memory location (1) number will remain on.

g. Turning Heater Off – All Modes.

Press heater on/off button (7) once. Heat signal to heater will turn off. Heater will do a normal cool down, then turn itself off.

OPERATE IN EXTREME HEAT

CAUTION

Limit unnecessary idling time to five minutes. Under no condition should idling time exceed a maximum of 10 minutes. Excessive idling can cause carbon buildup and damage to engine.

1. **General.** During very hot weather, driving procedures may require altering to prevent vehicle overheating. Avoid continuous long, hard pulls. Allow engine to idle if it becomes overheated. If engine does not cool sufficiently after a maximum of 10 minutes of idling, shut down and notify Unit Maintenance.
2. **Driving Vehicle.**
 - a. Check coolant temperature gauge and stop if temperature is unusually high. Allow vehicle to cool down.

OPERATE IN EXTREME HEAT - CONTINUED

- b. Check cooling system, air cleaner restriction indicator, and engine oil level frequently. Be sure that radiator is free of bugs, dust, and other foreign matter. Perform necessary services and notify Unit Maintenance of any unusual gauge readings or problems.
 - c. Notify Unit Maintenance to shorten rear axle differential oil change interval from interval designated in Unit PMCS.
3. **Parking Vehicle.**
- a. Park vehicle under cover or in the shade, if possible.
 - b. Ensure all tires are inflated to proper pressure.
 - c. Clean and lubricate vehicle with correct grade of lubricants to help prevent deterioration. Have Unit Maintenance change filter elements at shorter than normal intervals, as designated in Unit PMCS.

OPERATE IN MUD OR SOFT SURFACES

1. Before entering mud or other soft surfaces, check conditions, stop vehicle, and select appropriate transmission gear range. Enter soft area at a medium speed for gear range selected.
2. Maintain steady pressure on accelerator pedal to keep vehicle rolling until solid ground is reached. Do not accelerate to point where wheels spin and do not stop, if possible.
3. If vehicle gets stuck, try to pull out slowly in a low gear. Boards, brush, or similar materials may be placed under tires to provide traction.
4. Notify Unit Maintenance to clean and inspect propshaft for proper lubrication.

OPERATE IN SANDY OR DUSTY CONDITIONS

1. Maintain steady, even movement with transmission in lower gears. Try to keep vehicle rolling without straining engine and powertrain.
2. If vehicle bogs down, place boards, brush, canvas or similar materials under and in front of tires after shoveling a clear path ahead of each tire. This should improve traction.
3. If these efforts fail and it becomes evident that vehicle will not free itself, have another vehicle tow stuck vehicle (Refer to *Towing Tractor* in this work package).
4. Whenever operating in sandy or dusty areas, you should:
 - a. Ensure each tire has a valve cap.
 - b. Check engine coolant temperature and engine oil pressure frequently.

CAUTION

Limit unnecessary idling time to five minutes. Under no condition should idling time exceed a maximum of 10 minutes. Excessive idling can cause carbon buildup and damage to engine.

- c. If vehicle overheats, allow engine to idle. If engine does not cool sufficiently after a maximum of 10 minutes, shut down and notify Unit Maintenance.
- d. Ensure engine oil filler tube and transmission fluid filler tube are cleaned before dipsticks are removed to check fluid levels. Clean accumulations of sand and dirt from around any fluid filler locations before checking or adding fluids.
- e. Clean spouts of fuel containers and areas around filler caps on fuel tank before adding fuel. Under extremely sandy or dusty conditions, filter fuel when filling tank.
- f. Cover window glass to protect against sand blasting.
- g. Notify Unit Maintenance to clean, inspect, and lubricate drive shaft more frequently.

OPERATE ON SNOW OR ICE1. **Driving.**

- a. Accelerate slowly to avoid spinning tires.
- b. Drive at slower speeds.
- c. Give signals sooner.
- d. Apply brakes sooner to give early warning of intention to stop. This also helps to avoid skidding.
- e. Maintain double the normal distance from any vehicle ahead.
- f. Keep windshields, windows, mirrors, and vehicle lights free of snow and ice. Use defroster to help keep windshield and window glass free of snow and ice.
- g. Descend moderate grades in gear normally used for ascending same grade. On steep or very slippery grades, use at least one gear lower.
- h. After driving through slush or water, drive slowly and test brakes. Keep driving slowly, maintaining moderate pressure on service brake pedal to create a slight drag. When brakes are dry and operating properly, resume normal speed.
- i. If a difficult stretch of road surface approaches, stop and inspect it carefully before driving on it. Select transmission gear range that best suits surface condition.
- j. If vehicle becomes stuck or tires start spinning, it may be possible to rock vehicle out. Shift transmission to D (Drive). Apply light, steady throttle (never full throttle). When vehicle has moved as far as it will go, apply service brakes and allow engine to return to idle speed. Shift transmission to R (Reverse). Again, apply light, steady throttle and allow vehicle to move rearward as far as it will go. Apply service brakes and allow engine to return to idle speed. This procedure can be continued as long as each directional shift moves vehicle a greater distance. If not, vehicle should be towed from its position.

2. **Stopping.**

- a. Ease up on accelerator, leaving vehicle in gear.
- b. Apply service brakes lightly and evenly. DO NOT pump service brake pedal. Always avoid sudden braking.
- c. During emergency or reduced traction stops, press brake pedal fully until vehicle comes to a safe stop. DO NOT PUMP brake pedal.

3. **Parking.**

If parking on icy, slushy, wet or muddy surfaces, place boards, brush or other materials that would provide traction underneath tires. This guards against tires freezing to the ground or becoming pocketed in ice, and provides some traction when vehicle is started and moving again.

END OF WORK PACKAGE

INTRODUCTION

1. This work package shows the location for stowage of equipment and material required to be carried on the M878A2 Yard Tractor.
2. This work package also includes illustrations showing the location and contents of all decals, data plates, and stencils.

STOWAGE GUIDE

NOTE

Items listed in Table 1 below are illustrated in WP 0017 00, *Components of End Item (COEI) and Basic Issue Items Lists* or are listed in WP 0018 00, *Additional Authorization List (AAL)*.

Table 1. Stowage Guide.

ITEM	NOMENCLATURE	QTY	STOWAGE LOCATION
1	Bar, Breaker	1	Inside stowage compartment
2	Cable Assembly, Special Purpose, Electrical: 12V	1	Inside stowage compartment
3	Cable Assembly, Special Purpose, Electrical: 24V	1	Inside stowage compartment
4	Extinguisher, Fire	1	Mounted inside cab behind driver's seat
5	Handle, Jack: Cab Tilt Pump	1	Mounted inside cab behind driver's seat
6	Handle/Leverage Bar: Truck Wrench	1	Inside stowage compartment
7	Hose, Nonmetallic: Intervehicular, Emergency (Red)	1	Inside stowage compartment
7.1	Hose, Nonmetallic: Intervehicular, Service (Blue)	1	Inside stowage compartment
8	Inflator-Gage, Pneumatic Tire	1	Inside stowage compartment
9	Jack, Hydraulic: 12-Ton Capacity	1	Inside stowage compartment
10	Wrench, Socket: Metric, 22mm X 33 mm	1	Inside stowage compartment

DECALS

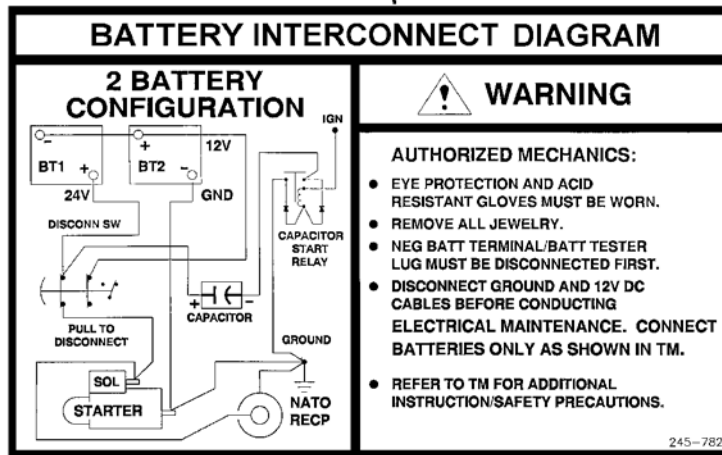

376-669

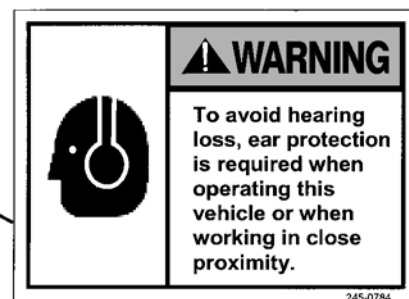

376-700

DECALS - CONTINUED

⚠ CAUTION

DO NOT use pump motor to lower cab.

Leave valve lever in return position when cab is down.

Leave valve lever in raise position when cab is tilted.

245K-0004

IMPORTANT

PLACE TRANS. SHIFT LEVER IN NEUTRAL POSITION AND APPLY PARK BRAKE BEFORE TILTING CAB

TO RAISE CAB

- PLACE PUMP CONTROL IN RAISE POSITION
- ACTIVATE PUMP

TO LOWER CAB

- PLACE PUMP CONTROL IN LOWER POSITION
- PULL RELEASE CABLE
- ACTIVATE PUMP
(MAINTAIN TENSION ON RELEASE CABLE UNTIL CAB BEGINS TO LIFT)

NOTE: PLACE PUMP LEVER IN LOWER POSITION WHEN NOT IN USE

245-0727

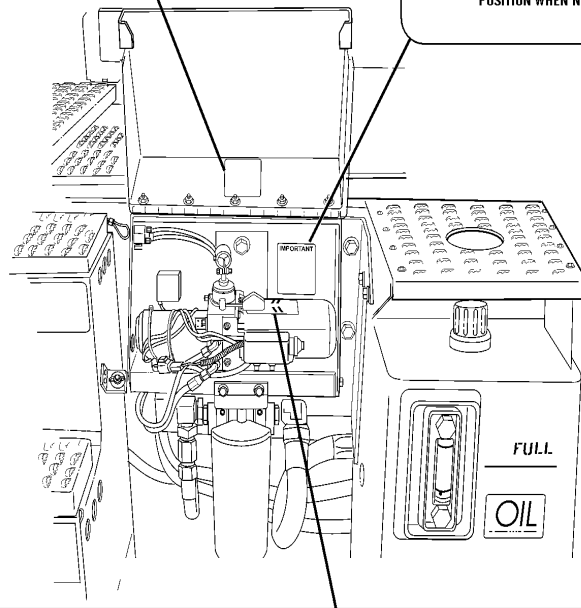

SELECTION LEVER

REVERSE LEVER TO SLOW AUTO DESCENT

TILT / RETURN

⚠ WARNING

1. Stand clear of cab.
2. Cab automatically descends after balancing point.
3. Use safety stop.
4. Cab creeps down without safety stop.
5. Read operating instructions.

FP2962026

376-087

DECALS - CONTINUED



245-353

⚠ CAUTION

**Do not drill frame flanges
or weld frame webs
Could cause frame failure**

OIL
SEE OPERATOR'S MANUAL
A245-0012

DECALS - CONTINUED

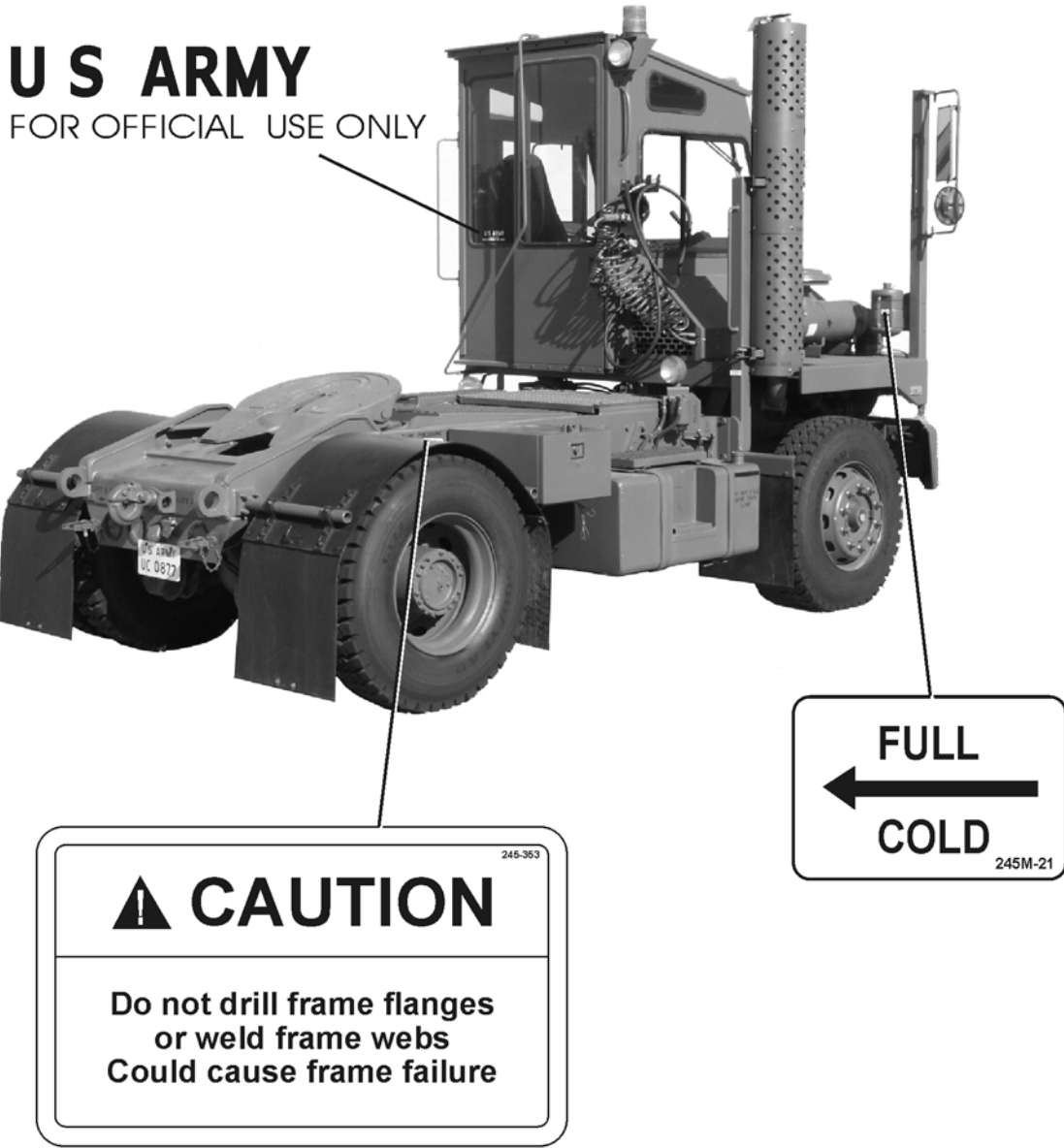

376-089

DECALS - CONTINUED

THIS VEHICLE IS DESIGNED FOR OFF-HIGHWAY USE ONLY

THE STANDARDS AND LAWS GOVERNING MOTOR VEHICLES OPERATED ON PUBLIC ROADS REQUIRE EMISSION, BRAKE, LIGHTING AND RESTRAINT SYSTEMS WHICH ARE DIFFERENT FROM THE EQUIPMENT ON THIS VEHICLE. THIS VEHICLE IS NOT DESIGNED FOR USE ON A PUBLIC ROAD OR HIGHWAY, AND OPERATION ON A ROAD OR HIGHWAY MAY INCREASE THE RISK OF INJURY OR COLLISION AND MAY VIOLATE STATE OR FEDERAL LAWS.

245-709



 CUSTOM TRUCKS
CRANE CARRIER COMPANY
VEHICLE NOISE EMISSION CONTROL INFORMATION

Date of Manufacture
 JUNE Mo 2001 yr.

This Vehicle Conforms to U.S. EPA Regulations for Noise Emission Applicable to Medium and Heavy Trucks.
 The following acts or the causing thereof by any person are prohibited the Noise Control Act of 1972; (A) The removal or rendering inoperative, other than for purposes of maintenance, repair, or replacement, of any noise control device or element of design (listed in the owner's manual) incorporated into this vehicle in compliance with the Noise Control Act; (B) The use of this vehicle after such device or element of design has been removed or rendered inoperative.

REV. E 245-443

MANUFACTURED BY: _____
 CRANE CARRIER COMPANY - TULSA, OKLAHOMA
 DATE OF MANUFACTURE MO. JUN/01 YR.
 GVWR 46,662 #
 GAWR FRONT: °
 16,302 # WITH
 11R22.5 (G) TIRES, RIMS 22.5x8.25
 @ 120 PSI SINGLE COLD
 GAWR INTERMEDIATE: _____ WITH
 _____ TIRES, RIMS _____
 @ _____ PSI _____ COLD
 GAWR REAR: °
 30,360 # WITH
 11R22.5 (G) TIRES, RIMS 22.5x8.25
 @ 120 PSI DUAL COLD
 THIS VEHICLE CONFORMS TO ALL APPLICABLE FEDERAL MOTOR VEHICLE SAFETY STANDARDS IN EFFECT AT TIME OF MANUFACTURE
 VEHICLE IDENTIFICATION NUMBER
 1CYEAA4861T044589
 VEHICLE TYPE: TRUCK
A245-706 Rev. A

DECALS - CONTINUED

Crane Carrier Company Parts Department P.O. Box 582891 1925 N. Sheridan Tulsa, OK 74158		PHONE: (918) 836-1651
		OR: (918) 832-7397
PARTS DATA PLATE		FAX: (918) 832-7399
Make and Model: _____	Centaur II CYT-1000	
Manufacturer Serial No: _____		
Registration No: _____		
Contract No: _____	GS-30F-96235 245-774, REV A	



376-090

INLET MANIFOLD HEATER OPERATION

TURN THE IGNITION ON AND WAIT UNTIL THE LAMP GOES OUT BEFORE ENGAGING THE STARTER. AFTER THE ENGINE HAS STARTED, MAINTAIN ENGINE AT LOW IDLE. THE LAMP WILL COME ON AND STAY ON UNTIL THE HEATER IS SHUT OFF BY THE ELECTRONIC CONTROL. APPLY LOAD TO ENGINE WITHIN 6 MINUTES. IF YOU GET A FLASHING INDICATOR LAMP, REFER TO YOUR LOCAL DEALER FOR REPAIRS.

101-9767

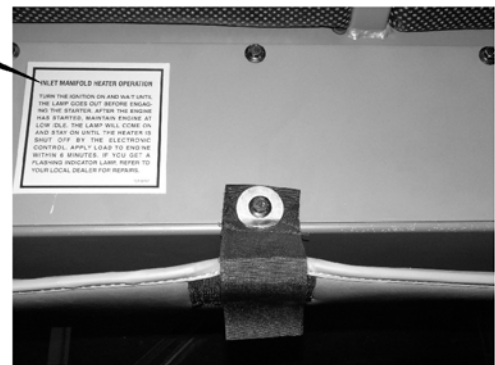

(ABOVE SUNVISOR)

376-053

DECALS - CONTINUED

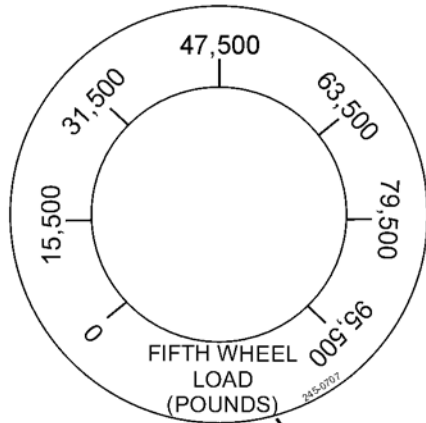

245-333

⚠ WARNING

Do not leave cab with engine running and transmission in gear. Neutral light must be on. Also required to start engine.

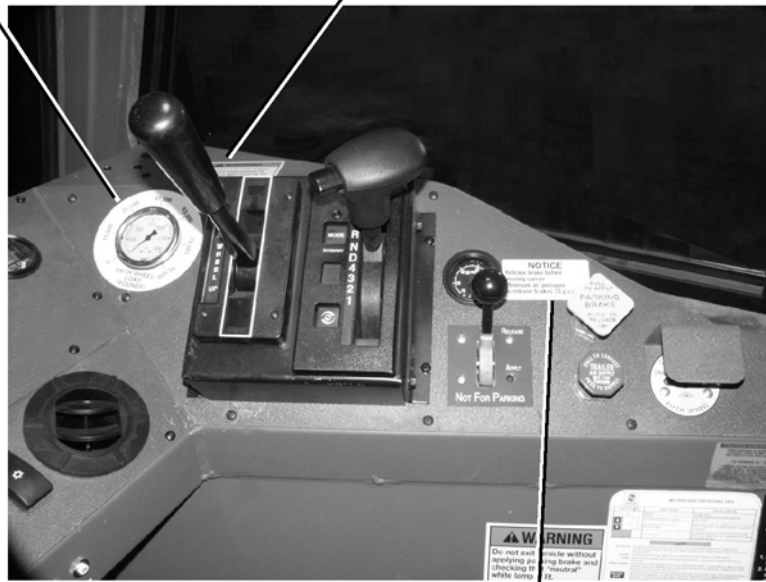

NOTICE

Release brake before moving carrier

Minimum air pressure to release brakes 75 p.s.i.

A245-525

DECALS - CONTINUED

MD 3060-3560 OPERATING TIPS

SELECTOR POSITION	RANGE COVERAGE	OPERATING CONDITIONS
R	REVERSE	BACKING VEHICLE
N	NEUTRAL	STARTING ENGINE AND STATIONARY OPERATION PAVED ROADS
D	(1-6) (1-5)	PAVED ROADS, OPERATOR DETERMINED FOR ROAD, LOAD AND TRAFFIC CONDITIONS. THE LOWER THE GEAR, THE GREATER THE BRAKING.
	(1-4) (1-3)	
	(1-2)	
1	1ST CONVERTER	OFF-HIGHWAY CONDITIONS, PULLING THROUGH MUD, DEEP SNOW, UP AND DOWN STEEP HILLS. MAXIMUM OUTPUT POWER AND MAXIMUM BRAKING.

CAUTIONS

MODE BUTTON: THE "MODE ON" LIGHT WILL INDICATE YOU HAVE SELECTED THE SECONDARY MODE FOR AN ALTERNATE SHIFT CALIBRATION AND/OR SPECIAL FUNCTION. BOTH PRIMARY AND SECONDARY CALIBRATIONS MAY OR MAY NOT UTILIZE ALL SIX GEAR RANGES.

STARTING: PLACE SELECTOR IN NEUTRAL. **NOTE:** ENGINE CANNOT BE STARTED BY PUSHING OR TOWING VEHICLE.

TOWING: BEFORE TOWING A DISABLED VEHICLE, DISCONNECT DRIVELINE OR PULL AXLE SHAFTS OR TOW WITH REAR WHEELS SUSPENDED.

DOWNHILL BRAKING: SELECT POSITION GIVING MAXIMUM SPEED DESIRED FOR DESCENDING GRADE. IF ENGINE RPM IS ALLOWED TO EXCEED GOVERNED SPEED, THE TRANSMISSION MAY UPSHIFT ABOVE THE HIGHEST SELECTED RANGE. DOWNSHIFTS TO LOWER RANGES WILL NOT OCCUR UNTIL SPEED IS REDUCED.

DO NOT SHIFT

CONTINUE TO DRIVE TO SAFE LOCATION FOR SERVICE ASSISTANCE. SELECTOR WILL "BEEP." SHIFTS WILL BE RESTRICTED AND LOCKUP WILL DISENGAGE. THE SHIFT SELECTOR WILL NOT RESPOND TO YOUR COMMANDS. RESTARTING THE ENGINE MAY CLEAR THE LIGHT ALLOWING NORMAL CONTINUED SERVICE. THE TRANSMISSION MAY, HOWEVER, HOLD IN NEUTRAL, REQUIRING IMMEDIATE ATTENTION.

TRANSMISSION SERVICE HINTS

- CHECK OIL AT NORMAL TEMPERATURE, NEUTRAL, BRAKES ON, IDLING.
- IF ADDING OIL, USE DEXRON IIE, DEXRON-III OR APPROVED TYPE C-4 FLUIDS ONLY.

SA 2261D 3/94

WARNING

Do not exit vehicle without applying parking brake and checking that "neutral" white lamp is lit.

245H-36

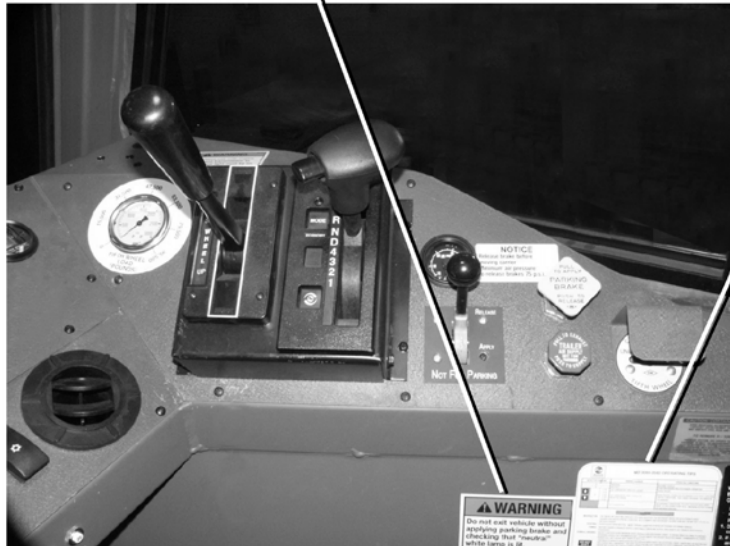

DECALS - CONTINUED

<p>CAUTION: CONTAINS R-134a</p> <p>AVOID BREATHING A/C REFRIGERANT AND LUBRICANT VAPOR OR MIST. EXPOSURE MAY IRRITATE EYES, NOSE AND THROAT.</p> <p>TO REMOVE R-134a</p> <p>FROM A/C SYSTEM, USE SERVICE EQUIPMENT CERTIFIED TO MEET THE REQUIREMENTS OF S.A.E. J2210. IF ACCIDENTAL SYSTEM DISCHARGE OCCURS, VENTILATE WORK AREA BEFORE RESUMING SERVICE. ADDITIONAL HEALTH AND SAFETY INFORMATION MAY BE OBTAINED FROM REFRIGERANT AND LUBRICANT MANUFACTURERS</p>	<p>AIR CONDITIONER</p> <p>RED DOT CORP. SEATTLE, WA MODEL NO.</p> <p>MAXIMUM OPERATING CHARGE OF REFRIGERANT: 3 LB. OZ.</p> <p>MAXIMUM OIL CHARGE: OZ.</p> <p>COMPLIES WITH SAE J639</p> <p>CAUTION</p> <p>REFRIGERANT UNDER HIGH PRESSURE SYSTEM TO BE SERVICED BY QUALIFIED PERSONNEL ONLY. IMPROPER SERVICE METHOD MAY CAUSE INJURY. CONSULT SHOP MANUAL</p> <p>FILL OUT AND ATTACH THIS LABEL TO VEHICLES</p>
--	---



IMPORTANT

WELDING PROCEDURES FOR VEHICLES EQUIPPED WITH ELECTRONIC ENGINE OR TRANSMISSION CONTROLS

If welding is required on vehicle, the following precautions are to be taken to protect the electronic components:

1. Disconnect positive and negative wiring connectors at the battery.
2. If additional electronic system ground wires are connected to the frame, they are to be disconnected.
3. Cover electronic components and wiring to protect from hot sparks, etc.
4. Do not connect welding cables to electronic components.

245J-0054

376-634

DECALS - CONTINUED

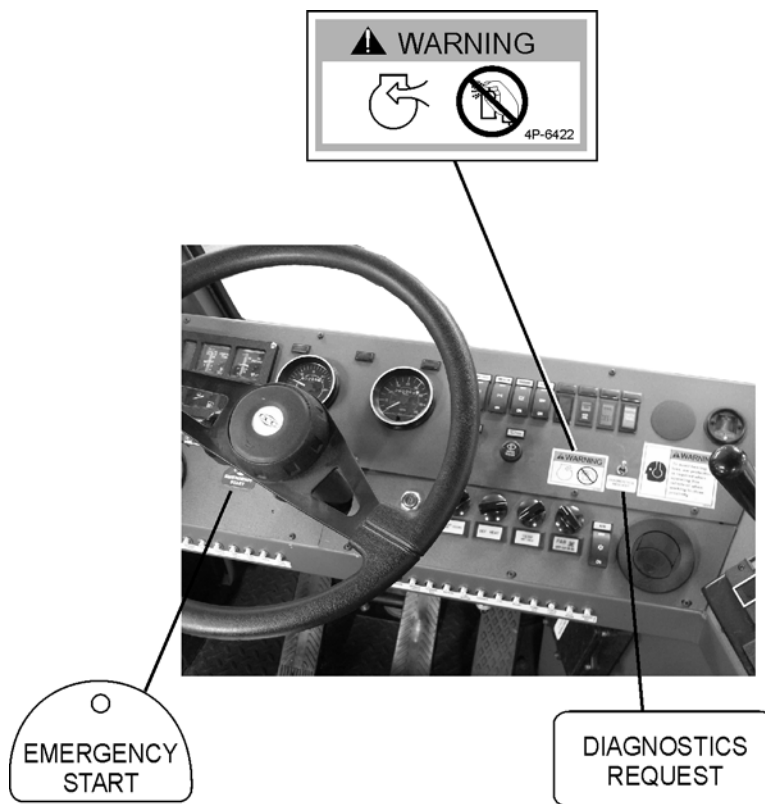

376-094

DECALS - CONTINUED

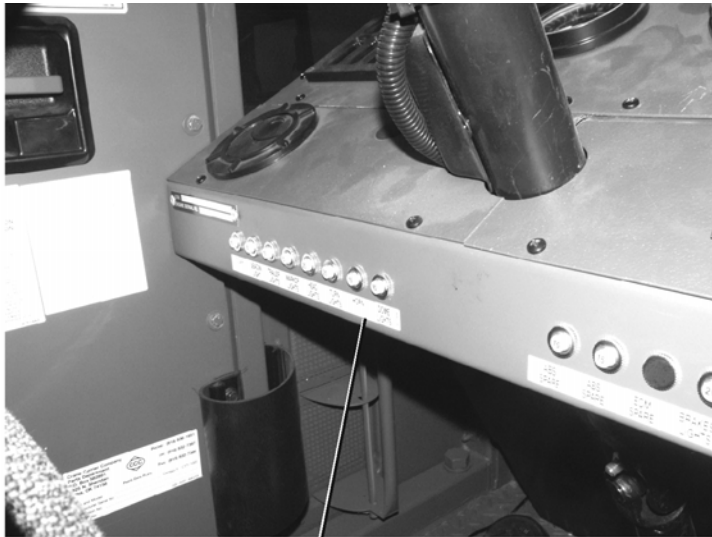

CIGAR	BEACON LIGHT	TRAILER LIGHTS	MARKER LIGHTS	HEAD LIGHTS	TURN LIGHTS	HORN	DOMES LIGHTS	245J-00090
-------	-----------------	-------------------	------------------	----------------	----------------	------	-----------------	------------

376-095



ABS SPARE	ABS SPARE	ECM SPARE	BRAKES LIGHTS	CHASSIS ACC	WIPERS	FUEL HEATER	GAUGES	PTO	START SOLENOID	PANEL ACC	FLOOD LIGHT	FUEL SOL KYSOR	HEATER A/C	245J-00091
--------------	--------------	--------------	------------------	----------------	--------	----------------	--------	-----	-------------------	--------------	----------------	-------------------	---------------	------------

376-096

DECALS - CONTINUED



376-638

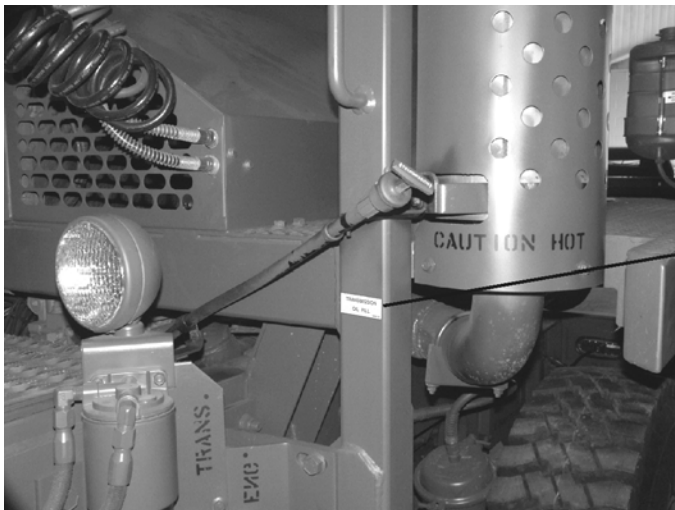

376-639

DECALS - CONTINUED**IMPORTANT NOTICE**

The cooling system in this vehicle is filled with 50% ethylene glycol solution anti-freeze, which protects to -34°F (-36.7°C). If lower temperatures are encountered, add anti-freeze as necessary. Anti-leak types are not recommended for diesel engine service.

245-129

▲ CAUTION

Automatic fan stops & starts by itself when engine is running. Keep hands clear to avoid injury.

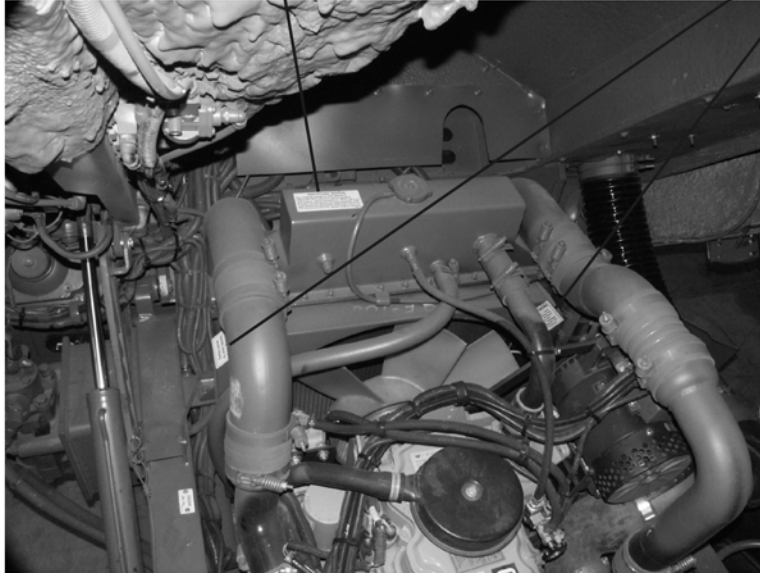

376-643

DECALS - CONTINUED



376-654

DATA PLATES

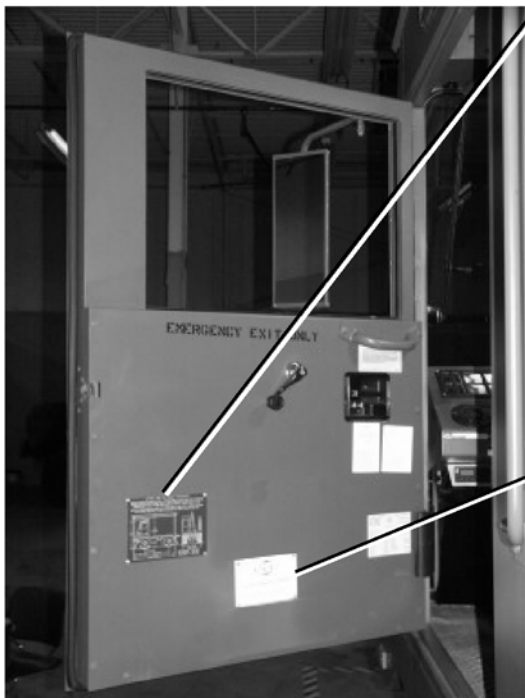
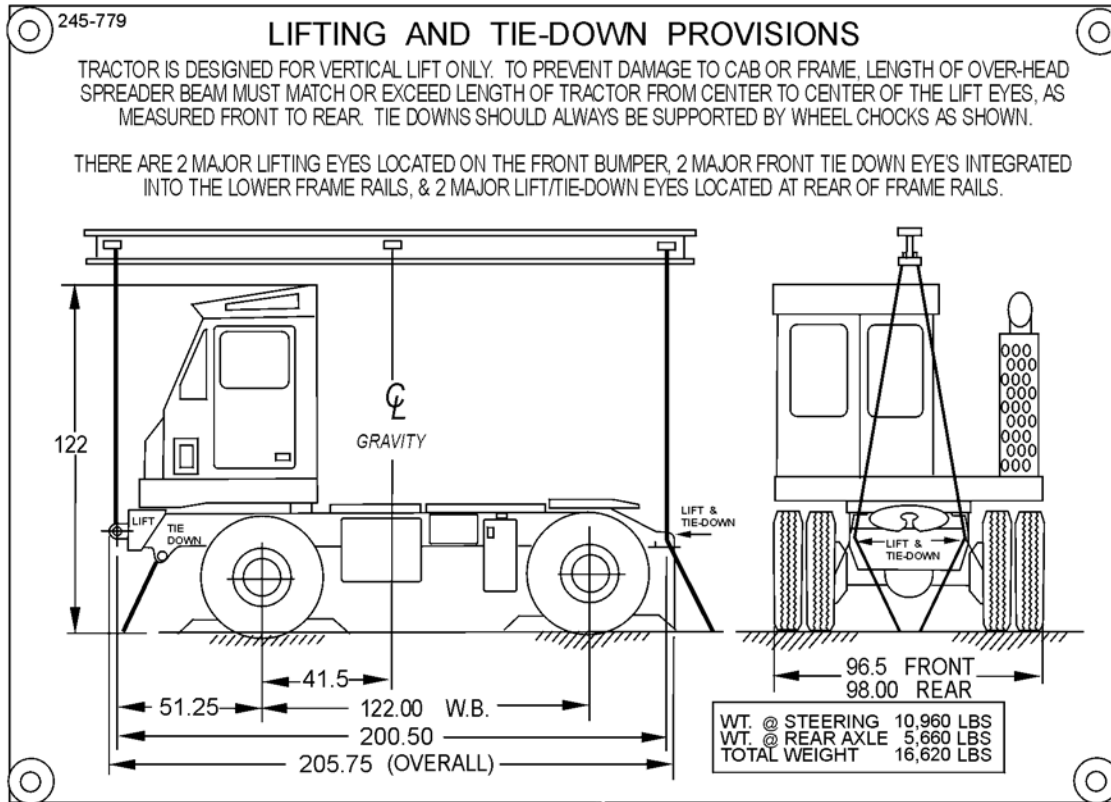

DATA PLATES - CONTINUED

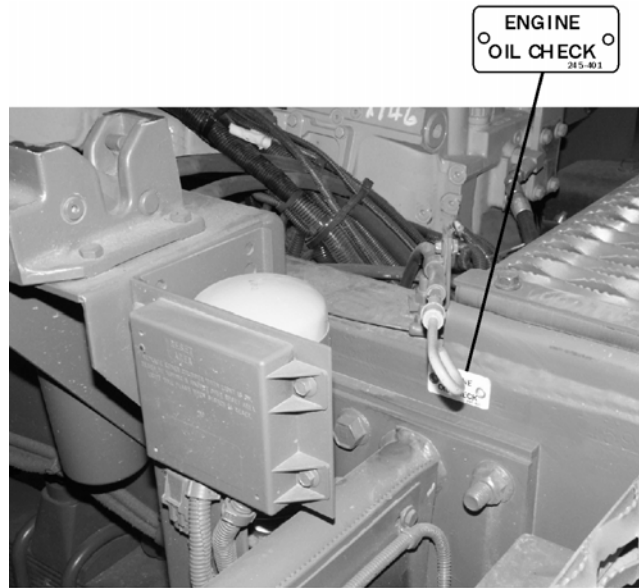

376-085

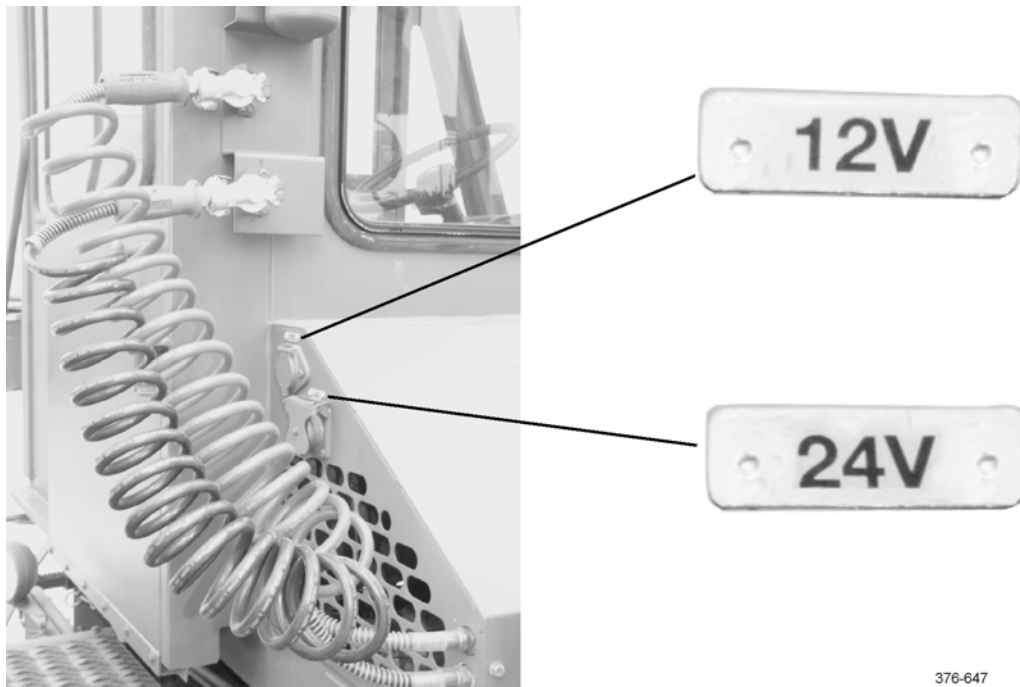

376-647

DATA PLATES - CONTINUED

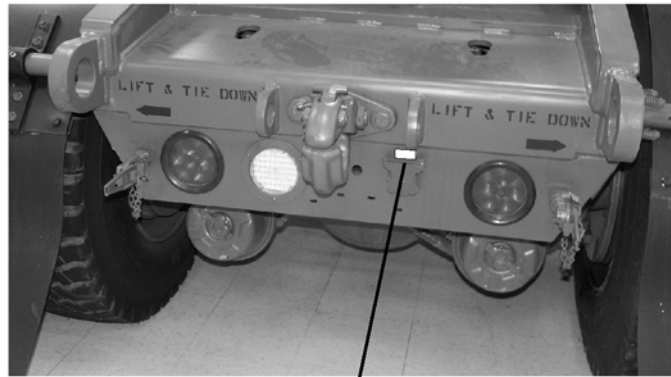

◦ 24V ◦

376-648

STENCILS

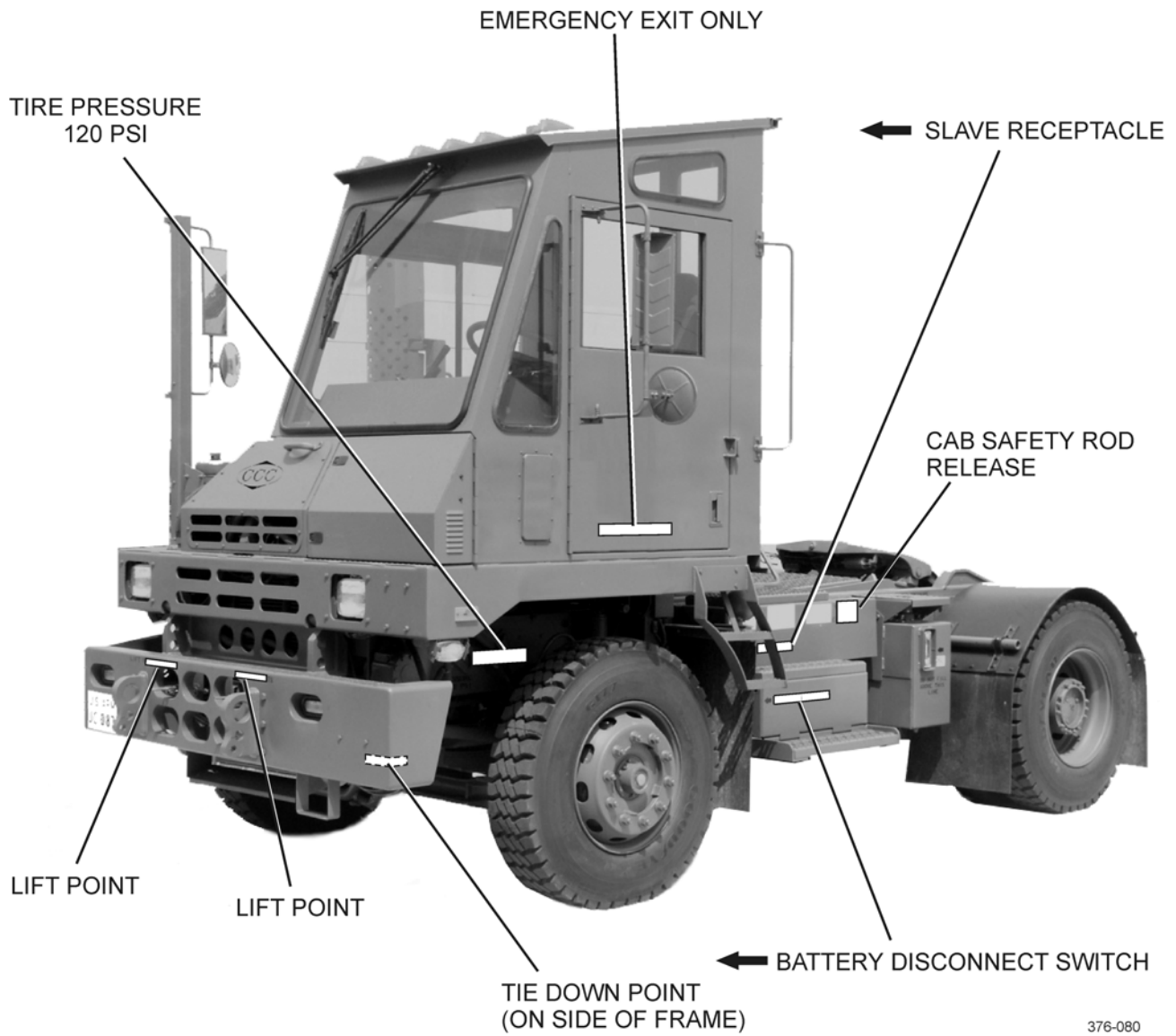

376-080

STENCILS - CONTINUED

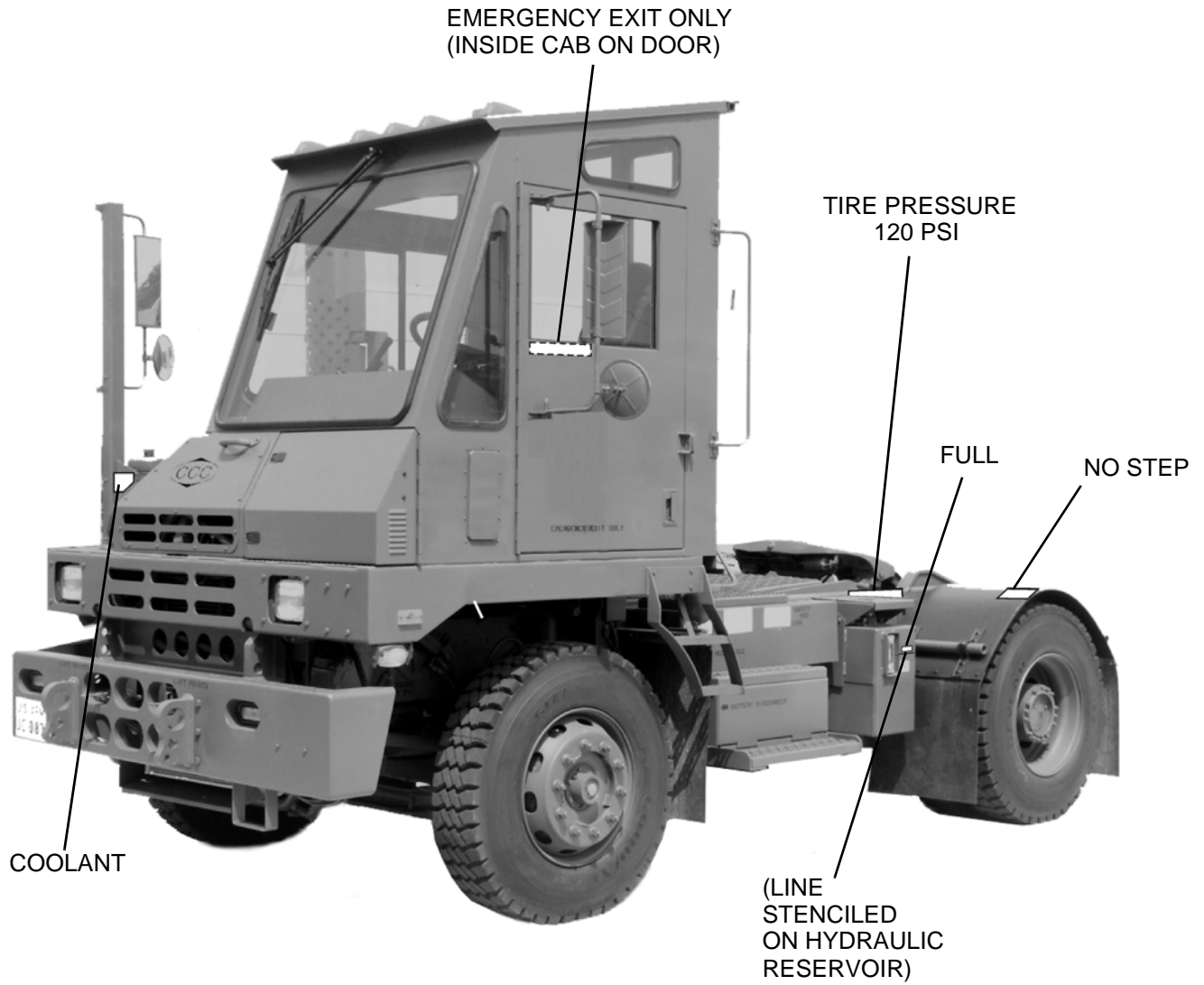

376-081

STENCILS - CONTINUED

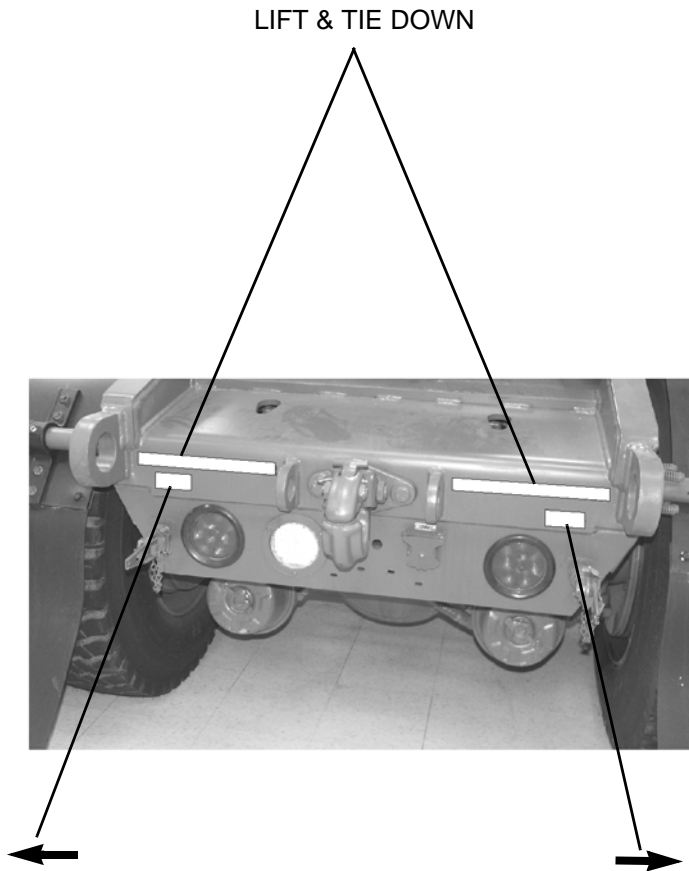

STENCILS - CONTINUED

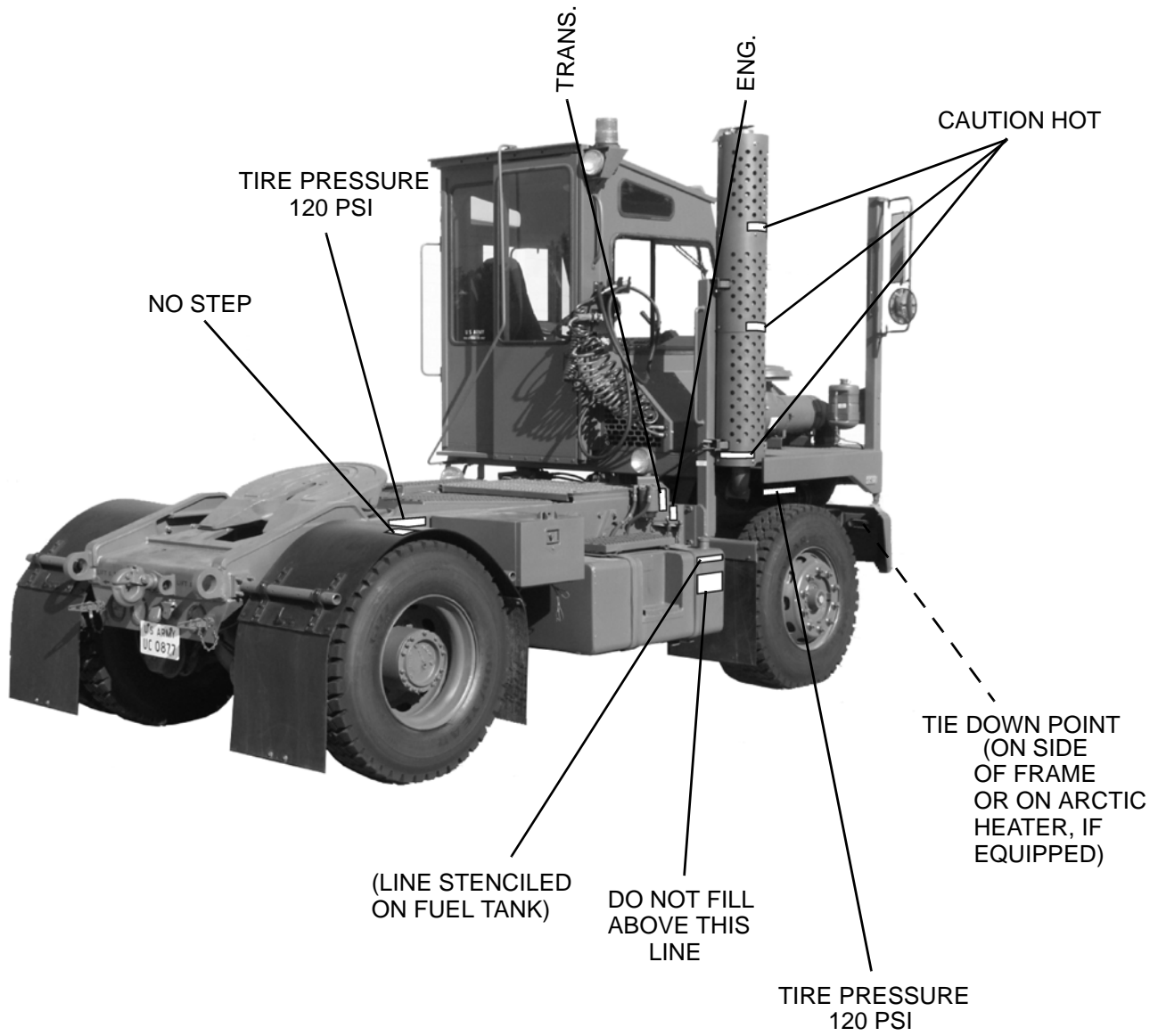

376-083

END OF WORK PACKAGE

CHAPTER 3
OPERATOR TROUBLESHOOTING

GENERAL

1. This chapter provides information for identifying and correcting malfunctions which may develop while operating the M878A2 Yard Tractor.
2. The Troubleshooting Symptom Index in WP 0009 00 lists common malfunctions which may occur and refers you to the proper page in WP 0010 00, Tables 1 through 9, for a troubleshooting procedure.
3. If you are unsure of the location of an item mentioned in troubleshooting, refer to WP 0002 00 or WP 0004 00.
4. Before performing troubleshooting, read and follow all safety instructions found in the Warning Summary at the front of this manual.
5. The Troubleshooting Symptom Index cannot list all malfunctions that may occur, nor all tests or inspections and corrective actions. If a malfunction is not listed, or is not corrected by the listed corrective actions, notify your supervisor.
6. When troubleshooting a malfunction:
 - a. Locate the symptom or symptoms in WP 0009 00 in that best describe the malfunction.
 - b. Turn to the page in WP 0010 00 where the troubleshooting procedures for the malfunction in question are described. Headings at the top of each page show how each troubleshooting procedure is organized: MALFUNCTION, TEST OR INSPECTION (in step number order), and CORRECTIVE ACTION.
 - c. Perform each step in the order listed until the malfunction is corrected. DO NOT perform any maintenance task unless the troubleshooting procedure tells you to do so.

EXPLANATION OF COLUMNS

The columns in WP 0010 00, Tables 1 through 9, are defined as follows:

1. **MALFUNCTION**. A visual or operational indication that something is wrong with the equipment.
2. **TEST OR INSPECTION**. A procedure to isolate the problem in a system or component.
3. **CORRECTIVE ACTION**. A procedure to correct the problem.

END OF WORK PACKAGE

TROUBLESHOOTING SYMPTOM INDEX

0009 00

Malfunction/Symptom **Troubleshooting Procedure**
(Work Package Number and Page Number)

AIR SYSTEM AND BRAKES

- 1. Air Reservoir Pressure Low (LOW AIR Warning Light and Buzzer are On) 0010 00-1
- 2. Air System Loses Pressure During Vehicle Operation or LOW
AIR Warning Light and Buzzer Come On During Vehicle Operation 0010 00-1
- 3. Trailer Brakes Will Not Apply When Brake Pedal or Trailer Brake Control Valve Lever
on Instrument Panel is Used 0010 00-1
- 4. Trailer Brakes Will Not Release 0010 00-2

AUXILIARY ARCTIC HEATER

- Auxiliary Arctic Heater Does Not Work 0010 00-2

CAB TILT SYSTEM

- 1. Cab Tilt System Operation is Erratic 0010 00-3
- 2. Cab Will Not Tilt When Power Button on Cab Tilt Pump is Pressed 0010 00-3

ELECTRICAL SYSTEM

- 1. Batteries Not Charging, Voltmeter Indicator in RED or YELLOW 0010 00-3
- 1.1 Engine Cranks But Fails to Start 0010 00-3
- 2. One or More Lighting Systems Not Working 0010 00-3

ENGINE

- 1. Engine Coolant Temperature Gauge (and Warning Light and Alarm)
Indicates Engine is Overheating 0010 00-4
- 2. Engine Cranks But Fails to Start 0010 00-4
- 3. Engine Does Not Develop Full Power 0010 00-4
- 4. Engine Does Not Idle Properly 0010 00-5
- 5. Engine Fails to Crank 0010 00-5
- 6. Engine Starts But Misfires or Runs Rough After Proper Warmup Period 0010 00-5
- 7. Engine Turns Over Very Slowly, RPM's Too Slow to Start 0010 00-5
- 8. Excessive Engine Oil Consumption 0010 00-5
- 9. Excessive Exhaust Smoke (at Normal Engine Operating Speed) 0010 00-5
- 10. Low or No Engine Oil Pressure 0010 00-5

FIFTH WHEEL

- 1. Fifth Wheel Jaws Will Not Open When Fifth Wheel Lock Control is
Placed in Unlock Position 0010 00-6
- 2. Fifth Wheel Will Not Respond to UP or DN Position of Fifth Wheel Lift
Control 0010 00-6

TROUBLESHOOTING SYMPTOM INDEX - CONTINUED

0009 00

STEERING

- 1. Hard Steering, Shimmy or Wandering 0010 00-6
- 2. Vehicle Steering Slow or Intermittent to Respond 0010 00-6

TRANSMISSION

- Slow or Erratic Transmission Operation 0010 00-7

WHEELS AND TIRES

- 1. Tires Worn Unevenly or Excessively 0010 00-7
- 2. Vehicle Wanders or Pulls to One Side on Level Pavement 0010 00-7
- 3. Wheel Wobbles 0010 00-7

END OF WORK PACKAGE

Table 1. Air System and Brakes Troubleshooting Procedures.

MALFUNCTION	TEST OR INSPECTION	CORRECTIVE ACTION
<p>1. Air Reservoir Pressure Low (LOW AIR Warning Light and Buzzer are On).</p> <p>2. Air System Loses Pressure During Vehicle Operation or LOW AIR Warning Light and Buzzer Come On During Vehicle Operation.</p>	<p>1. Check whether air reservoir draincocks are closed.</p> <p>2. If vehicle is not coupled to a trailer, check position of trailer air supply control knob.</p> <p>3. Notify Unit Maintenance.</p>	<p>Close draincocks.</p> <p>Pull knob out (OFF).</p>
<p>NOTE</p> <p>Any change in pressure on brake pedal will cause a change in air pressure reading on gauge.</p>		
	<p>1. Ensure trailer air supply control knob is pulled out (OFF). Operate engine until warning light goes off and release parking brake. Stop engine and note reservoir pressure. Fully press and hold service brake pedal for two minutes.</p>	<p>If leaks are present, notify Unit Maintenance.</p>
<p>NOTE</p> <p>Any change in pressure on brake pedal will cause a change in air pressure reading on gauge.</p>		
<p>3. Trailer Brakes Will Not Apply When Brake Pedal or Trailer Brake Control Valve Lever on Instrument Panel is Used.</p>	<p>2. Push trailer air supply control knob in (ON) to charge trailer air reservoirs and repeat step 1.</p> <p>Check intervehicular air hoses for proper connections to trailer.</p>	<p>If air leaks are present, notify Unit Maintenance.</p> <p>Connect air hoses.</p>

Table 1. Air System and Brakes Troubleshooting Procedures - Continued.

MALFUNCTION	TEST OR INSPECTION	CORRECTIVE ACTION
<p>4. Trailer Brakes Will Not Release.</p>	<ol style="list-style-type: none"> 1. Check position of trailer brake hand control valve lever on instrument panel. 2. Check position of trailer air supply control knob. 3. Check intervehicular air hoses for proper connections. 4. Notify Unit Maintenance. 	<p>Move lever up to OFF position.</p> <p>Push knob in (ON).</p> <p>Connect air hoses.</p>

Table 2. Auxiliary Arctic Heater Troubleshooting Procedures.

MALFUNCTION	TEST OR INSPECTION	CORRECTIVE ACTION
<p>NOTE</p> <ul style="list-style-type: none"> • The 7-day timer has a fault code retrieval device built into the unit. This function automatically activates if heater is experiencing problems. Fault codes appear in 3-digit format on the LCD display screen. Fault code 000 indicates normal operation. • Operator troubleshooting is limited. If any fault code other than 000 appears, check for the following: <ol style="list-style-type: none"> a. Is battery disconnect switch in OFF position? If so, place in ON position. b. Is there adequate fuel in fuel tank? If not, refuel (WP 0013 00). c. Is vehicle heater set to maximum temperature setting? If not, set to maximum setting (Refer to <i>Operate Heater</i> in WP 0005 00). d. Is circuit breaker located on front of auxiliary arctic heater unit tripped? If tripped, press to reset. • If fault code remains, notify Unit Maintenance. 		

Table 3. Cab Tilt System Troubleshooting Procedures.

MALFUNCTION	TEST OR INSPECTION	CORRECTIVE ACTION
<p>1. Cab Tilt System Operation is Erratic.</p> <p>2. Cab Will Not Tilt When Power Button on Cab Tilt Pump is Pressed.</p>	<p>1. With ignition on, check that voltmeter on instrument panel indicates adequate state of charge.</p> <p>2. Check cab tilt pump for loose or damaged wires and connectors.</p> <p>3. Check for hydraulic oil leaks at pump fittings and in hoses and fittings between pump, hydraulic cylinder, and cab tilt latch.</p>	<p>Notify Unit Maintenance.</p> <p>Notify Unit Maintenance if voltmeter indicates vehicle batteries are dead.</p> <p>1. Connect electrical connector, if disconnected.</p> <p>2. If wires are loose or damaged, notify Unit Maintenance.</p> <p>If leaks are found, notify Unit Maintenance.</p>

Table 4. Electrical System Troubleshooting Procedures.

MALFUNCTION	TEST OR INSPECTION	CORRECTIVE ACTION
<p>1. Batteries Not Charging, Voltmeter Indicator in RED or YELLOW.</p> <p>1.1 Engine Cranks But Fails to Start</p> <p>2. One or More Lighting Systems Not Working.</p>	<p>1. Check for loose or broken battery cables.</p> <p>2. Shut down engine and perform slave starting procedures (WP 0006 00).</p> <p>Attempt to start engine using emergency start switch (WP 0005 00).</p> <p>1. Check position of switch(es). If vehicle is coupled to trailer and problem is with trailer lighting system, check intervehicular electrical cable connection.</p> <p>2. Check if applicable circuit breaker on instrument panel is tripped.</p> <p>3. Notify Unit Maintenance to perform trailer troubleshooting.</p>	<p>Notify Unit Maintenance.</p> <p>If charging problem is not corrected by slave starting, notify Unit Maintenance.</p> <p>1. If engine does not start, perform slave starting procedures (WP 0006 00).</p> <p>2. If engine still fails to start, notify Unit Maintenance.</p> <p>Place switch(es) in ON position. Connect intervehicular electrical cable.</p> <p>Push in to reset circuit breaker.</p>

Table 5. Engine Troubleshooting Procedures.



MALFUNCTION	TEST OR INSPECTION	CORRECTIVE ACTION
<p>1. Engine Coolant Temperature Gauge (and Warning Light and Alarm) Indicates Engine is Overheating.</p> <div style="text-align: center;">   <p>WARNING</p> </div> <ul style="list-style-type: none"> • DO NOT service cooling system unless engine has cooled to 120°F (50°C) as indicated on coolant temperature gauge. This is a pressurized cooling system and escaping steam or hot coolant will cause serious burns. • Wear effective eye, glove, and skin protection when handling coolants. Failure to do so may cause injury. 	<ol style="list-style-type: none"> 1. Check engine coolant level in coolant overflow bottle. 2. Check cooling system for leaks. 3. Check if radiator cooling fins are free of mud, snow, ice or debris. 4. Check serpentine drive belt for looseness. 5. Check engine oil level. 6. Check transmission fluid level. 	<p>If coolant is low, fill to correct level (WP 0011 00 and WP 0012 00).</p> <p>If leaks are found, notify Unit Maintenance.</p> <p>Remove anything that blocks or impedes cooling fins.</p> <p>If belt is loose, notify Unit Maintenance.</p> <p>If engine oil is low, fill to correct level (WP 0011 00 and WP 0012 00).</p> <p>If transmission fluid level is low, fill to correct level (WP 0011 00 and WP 0012 00).</p>
<p>2. Engine Cranks But Fails to Start.</p>	<ol style="list-style-type: none"> 1. Check fuel gauge with ignition switch in ON position. 2. Check air cleaner restriction indicator. 3. If below 32°F (0°C), check indicator light on ether electronic control relay. 	<ol style="list-style-type: none"> 1. If empty, add fuel (WP 0013 00). 2. If engine still fails to start, prime fuel system (WP 0013 00). <p>If yellow band has risen to red area on gauge, service engine air cleaner (WP 0015 00).</p> <p>If red light is on, notify Unit Maintenance.</p>
<p>3. Engine Does Not Develop Full Power.</p>	<p>Check air cleaner restriction indicator.</p>	<p>If yellow band has risen to red area on gauge, service engine air cleaner (WP 0015 00).</p>

Table 5. Engine Troubleshooting Procedures - Continued.

MALFUNCTION	TEST OR INSPECTION	CORRECTIVE ACTION
4. Engine Does Not Idle Properly.	Check air cleaner restriction indicator.	If yellow band has risen to red area on gauge, service engine air cleaner (WP 0015 00).
5. Engine Fails to Crank.	1. Check position of transmission range selector.	Range selector should be in N (Neutral) position.
	2. Attempt to start engine using emergency start switch (WP 0004 00).	Turn ignition switch to ON, place emergency start switch in (ON) position, then start engine.
	3. Ensure battery disconnect switch is in ON position.	Place switch in ON position.
	4. Ensure ignition system 25A circuit breaker is not tripped (located in top left corner of battery box above NATO slave receptacle).	Reset circuit breaker.
	5. Check for loose or broken battery cables.	If cables are loose or broken, notify Unit Maintenance.
6. Engine Starts But Misfires or Runs Rough After Proper Warmup Period.	1. Check air cleaner restriction indicator.	If yellow band has risen to red area on gauge, service engine air cleaner (WP 0015 00).
	2. Check fuel/water separator for water or sediment in sediment bowl.	Drain fuel/water separator (WP 0012 00).
7. Engine Turns Over Very Slowly, RPM's Too Slow to Start.	Check for loose or broken battery cables.	If loose or broken cables are found, notify Unit Maintenance.
8. Excessive Engine Oil Consumption.	Check for loose oil lines and oil leaks.	If oil lines are loose or leaks are found, notify Unit Maintenance.
9. Excessive Exhaust Smoke (at Normal Engine Operating Speed).	1. Check air cleaner restriction indicator.	If yellow band has risen to red area on gauge, service engine air cleaner (WP 0015 00).
	2. Check fuel/water separator for water or sediment in sediment bowl.	Drain fuel/water separator (WP 0012 00).
10. Low or No Engine Oil Pressure.	Check engine oil level.	If engine oil is low, fill to correct level (WP 0011 00 and WP 0012 00).

Table 6. Fifth Wheel Troubleshooting Procedures.

MALFUNCTION	TEST OR INSPECTION	CORRECTIVE ACTION
1. Fifth Wheel Jaws Will Not Open When Fifth Wheel Lock Control is Placed in Unlock Position.	1. Check whether manual secondary lock handle is engaged.	Disengage manual secondary lock handle.
	2. Check air pressure gauge for proper air pressure.	If gauge or LOW AIR warning light and buzzer indicate low air pressure, notify Unit Maintenance.
	3. Check air system at fifth wheel for leaks or damage.	If air lines or air cylinder are leaking or damaged, notify Unit Maintenance.
	4. Check for damage to fifth wheel jaws and locking components.	If damaged, notify Unit Maintenance.
2. Fifth Wheel Will Not Respond to UP or DN Position of Fifth Wheel Lift Control.	1. Check hydraulic fluid level in reservoir.	Add hydraulic fluid as necessary (WP 0011 00 and WP 0012 00).
	2. Check for damage and oil leaks in hoses and hydraulic cylinders.	If damage or leaks are found, notify Unit Maintenance.

Table 7. Steering Troubleshooting Procedures.

MALFUNCTION	TEST OR INSPECTION	CORRECTIVE ACTION
1. Hard Steering, Shimmy or Wandering.	NOTE Check tire pressure when tires are cold.	
	1. Check that tires are inflated to 120 psi (827 kPa).	Inflate tires to proper pressure.
2. Vehicle Steering Slow or Intermittent to Respond.	2. Check for loose wheel nuts.	Tighten loose wheel nuts and notify Unit Maintenance to apply proper torque.
	1. Check fluid level in hydraulic reservoir.	If fluid level is low, fill to correct level (WP 0011 00 and WP 0012 00).
	2. Check for leaks.	If leaks are found, notify Unit Maintenance.

Table 8. Transmission Troubleshooting Procedures.

MALFUNCTION	TEST OR INSPECTION	CORRECTIVE ACTION
Slow or Erratic Transmission Operation.	Check transmission fluid level.	1. If transmission fluid is low, fill to correct level (WP 0011 00 and WP 0012 00). 2. If malfunction persists, notify Unit Maintenance.

Table 9. Wheels and Tires Troubleshooting Procedures.

MALFUNCTION	TEST OR INSPECTION	CORRECTIVE ACTION
1. Tires Worn Unevenly or Excessively. 2. Vehicle Wanders or Pulls to One Side on Level Pavement. 3. Wheel Wobbles.	1. Check that tires are inflated to 120 psi (827 kPa). 2. Check for loose wheel nuts. 1. Check that tires are inflated to 120 psi (827 kPa). 2. Check that tires are proper size and type. Check for loose or missing wheel nuts.	Inflate tires to proper pressure. Tighten loose wheel nuts and notify Unit Maintenance to apply proper torque. If wheel nuts are missing, notify Unit Maintenance Inflate tires to proper pressure. If one tire is mismatched and spare matches, replace mismatched tire with spare. If one or more tires are mismatched, notify Unit Maintenance. Tighten loose wheel nuts and notify Unit Maintenance to apply proper torque. If lug nuts are missing, notify Unit Maintenance.

END OF WORK PACKAGE

CHAPTER 4
OPERATOR MAINTENANCE INSTRUCTIONS

GENERAL

To ensure that the M878A2 Yard Tractor is ready for operation at all times, it must be inspected and lubricated on a regular basis so that defects may be found and corrected before they result in serious damage, equipment failure or injury to personnel. Table 1 in WP 0012 00 contains systematic instructions on inspections, lubrication, adjustments, and corrections to be performed by the operator to keep your equipment in good operating condition and ready for its primary mission.

EXPLANATION OF TABLE ENTRIES

1. **Item Number (Item No.) Column.** Numbers in this column are for reference. When completing DA Form 2404 (*Equipment Inspection and Maintenance Worksheet*), include the item number for the check/service indicating a fault. Item numbers also appear in the order that you must perform checks and services for the interval listed.
2. **Interval Column.** This column tells you when you must perform the procedure in the procedure column.
 - a. *Before* procedures must be done immediately before you operate the tractor.
 - b. *During* procedures must be done while you are operating the tractor.
 - c. *After* procedures must be done immediately after you have operated the tractor.
 - e. *Monthly* procedures must be done once each month.
3. **Location, Item to Check/Service Column.** This column provides the location and item to be checked or serviced.

NOTE

The WARNINGS and CAUTIONS appearing in your PMCS table should always be observed. WARNINGS and CAUTIONS appear before applicable procedures. You must observe these WARNINGS to prevent serious injury to yourself and others, and CAUTIONS to prevent your equipment from being damaged.

4. **Procedure Column.** This column gives the procedure you must perform to check or service the item listed in the Item to Check/Service column, to know if the equipment is ready or available for its intended mission or for operation. You must perform the procedure at the time stated in the interval column.
5. **Not Fully Mission Capable If: Column.** Information in this column tells you what faults will keep your equipment from being capable of performing its primary mission. If you perform check/service procedures that show faults listed in this column, the equipment is not mission-capable. Follow standard operating procedures for maintaining the equipment or reporting equipment failure.

GENERAL PMCS PROCEDURES

1. Always perform PMCS in the same order so it gets to be a habit. Once you've had some practice, you'll spot anything wrong in a hurry. If the tractor does not perform as required, refer to the appropriate troubleshooting procedure in Chapter 3.
2. If anything looks wrong and you can't fix it, write it on your DA Form 2404. If you find something seriously wrong, IMMEDIATELY report it to your supervisor.
3. Before performing preventive maintenance, read all the checks required for the applicable interval and prepare all the tools you need to make all the checks. You'll always need a rag (Item 15, WP 0019 00) or two.

**PREVENTIVE MAINTENANCE CHECKS
AND SERVICES (PMCS) INTRODUCTION - CONTINUED**

0011 00

GENERAL PMCS PROCEDURES - CONTINUED

Dry cleaning solvent MIL-PRF-680 Type III is an environmentally compliant and low toxic material. However, it may be irritating to the eyes and skin. The use of protective gloves and goggles is suggested. Use in well-ventilated areas. Keep away from open flames and other sources of ignition.

- a. **Keep It Clean.** Dirt, grease, oil, and debris get in the way and may cover up a serious problem. Clean as you work and as needed. Use dry cleaning solvent (Item 3, WP 0019 00) on all metal surfaces. Use detergent (Item 5, WP 0019 00) and water when you clean rubber, plastic, and painted surfaces.
- b. **Rust and Corrosion.** Check metal parts for rust and corrosion. If any bare metal or corrosion exists, clean and apply a light coat of lubricating oil (Item 12, WP 0019 00). Report it to your supervisor.
- c. **Bolts, Nuts, and Screws.** Check bolts, nuts, and screws for obvious looseness, missing, bent, or broken condition. You can't try them all with a tool, but look for chipped paint, bare metal, or rust around bolt heads. If you find one you think is loose, tighten it.
- d. **Welds.** Look for loose or chipped paint, rust, or gaps where parts are welded together. If you find a bad weld, report it to your supervisor.
- e. **Electric Wires and Connectors.** Look for cracked or broken insulation, bare wires, and loose or broken connectors. Tighten loose connectors and ensure that the wires are in good condition.
- f. **Hoses and Fluid Lines.** Look for wear, damage, and signs of leaks. Ensure that clamps and fittings are tight. Wet spots indicate leaks, but a stain around a fitting or connector can also mean a leak. If a leak comes from a loose fitting or connector, tighten it. If something is broken or worn out, report it to your supervisor.
- g. **Fluid Leakage.** It is necessary for you to know how fluid leakage affects the status of your vehicle. The following are definitions of the types/classes of leakage that determine the status of your vehicle. Learn and be familiar with them, and remember - when in doubt, notify your supervisor.

CAUTION

Operation is allowable with Class I and Class II leakage. **WHEN IN DOUBT, NOTIFY YOUR SUPERVISOR.** When operating with Class I or Class II leaks, check fluid levels more frequently. Class III leaks must be reported immediately to your supervisor. Failure to do this will result in damage to vehicle and/or components.

Leakage Definitions for PMCS

Class I	Leakage indicated by wetness or discoloration, but not great enough to form drops.
Class II	Leakage great enough to form drops, but not enough to cause drops to drip from the item being checked/inspected.
Class III	Leakage great enough to form drops that fall from the item being checked/inspected.

**PREVENTIVE MAINTENANCE CHECKS
AND SERVICES (PMCS) INTRODUCTION - CONTINUED**

0011 00

GENERAL LUBRICATION PROCEDURES**NOTE**

- Lubrication instructions contained in this PMCS are MANDATORY.
 - If the M878A2 is not enrolled in the Army Oil Analysis Program (AOAP) for sampling of engine oil and transmission fluid, hardtime intervals apply.
 - Overall views of lubrication points are located at the end of this work package. Localized views are located, together with specific lubrication instructions, in the PMCS Table (WP 0012 00).
 - Refer to FM 9-207 for lubrication in arctic operation.
1. Included in this PMCS are lubrication services to be performed by the operator.
 2. Lubrication intervals are based on normal operation. Lubricate more during constant use and less during inactive periods. Use correct grade of lubricant for seasonal temperature expected (Refer to *KEY* on page 0011 00-4).
 3. For equipment under manufacturer's warranty, hardtime intervals shall be followed. Shorten intervals if lubricants are known to be contaminated or if operation is under adverse conditions (e.g., longer than usual operating hours, extended idling periods, extreme dust, etc.).
 4. Keep all lubricants in a closed container and store in a clean, dry place away from extreme heat. Keep container covers clean and do not allow dust, dirt or other foreign material to mix with lubricants. Keep lubrication equipment clean and ready for use.

**WARNING**

Dry cleaning solvent MIL-PRF-680 Type III is an environmentally compliant and low toxic material. However, it may be irritating to the eyes and skin. The use of protective gloves and goggles is suggested. Use in well-ventilated areas. Keep away from open flames and other sources of ignition.

5. Clean area around lubrication points with dry cleaning solvent (Item 3, WP 0019 00) or equivalent before lubricating equipment. Keep all external parts of equipment not requiring lubrication free of lubricants. After lubrication, wipe off excess lubricant to prevent accumulation of foreign matter.
6. Maintain a record of lubrication performed and report any problems noted during lubrication. Refer to DA Pam 738-750 for forms and procedures to record and report any findings.

NOTE

Only lubricants authorized for use by the operator, when lubricating during Operator PMCS, are listed in this KEY. For a complete list of lubricants, refer to TM 9-2320-312-24, Unit PMCS.

- KEY -

LUBRICANT/ COMPONENT	REFILL CAPACITY	EXPECTED TEMPERATURES*			INTERVALS
		+6°F to +122°F (-14°C to +50°C)	-4°F to +50°F (-20°C to +10°C)	-67°F to +32°F (-55°C to 0°C)	
OE/HDO Lubricating Oil, ICE, Tactical					D - Daily M - Monthly OC - On Condition
OEA Lubricating Oil, ICE, Arctic					
Engine Crankcase w/Filter	3 Qt (2.8 L) Filter 24-27 Qt (22.7-25.5 L) System Capacity	See Chart A			
Oil Can Points	As Req'd	See Chart A			
Dexron III Hydraulic Fluid, Automatic Transmission					
Transmission	26 Qt (25 L)	All Temperatures			
OHA Hydraulic Fluid, Petro- leum Base					
Hydraulic Reser- voir (Power Steer- ing and Fifth Wheel Lift)	1 Pt (0.5 L) Filter 12 Gal (45.2 L) Reservoir 15 Gal (56.8 L) System Capacity	See Chart B			
GAA Grease, Automotive and Artillery					
Fifth Wheel		All Temperatures			
ANTIFREEZE Ethylene Glycol, Inhib- ited, Heavy Duty					
Engine Radiator	4.7 Gal (17.8 L) Radiator 27.5 Qt (26.0 L) System Capacity	All Temperatures			

* For arctic operation, refer to FM 9-207.

CHART A—ENGINE AND OIL CAN POINTS

Lubricant	EXPECTED TEMPERATURES																			
	°F	-70	-60	-50	-40	-30	-20	-10	0	+10	+20	+30	+40	+50	+60	+70	+80	+90	+100	+120
	°C	-57	-51	-46	-40	-34	-29	-23	-18	-12	-7	-1	+4	+10	+16	+21	+27	+32	+38	+49
OE/HDO	Lubricating Oil, ICE, Tactical																			
OEA	Lubricating Oil, ICE, Arctic																			
OE/HDO-15W/40																				
OE/HDO 10W/30																				
OE/HDO-10*																				
OEA *																				

*If OEA lubricant is required to meet the low expected-temperature range, OEA lubricant is to be used in lieu of OE/HDO-10 lubricant for all expected temperatures where OE/HDO-10 is specified.

CHART B—HYDRAULIC FLUID (POWER STEERING/FIFTH WHEEL LIFT)

Lubricant	EXPECTED TEMPERATURES																			
	°F	-90	-80	-70	-60	-50	-40	-30	-20	-10	0	+10	+20	+30	+40	+50	+60	+70	+90	+90
	°C	-68	-62	-57	-51	-46	-40	-34	-29	-23	-18	-12	-7	-1	+4	+10	+16	+21	+27	+32
OHA	Fluid, Hydraulic, Petroleum Base																			
OHA	Fluid, Hydraulic, Petroleum Base																			
MIL-PRF-1762																				
MIL-H-5606																				

LUBRICANT • INTERVAL

INTERVAL • LUBRICANT

M878A2

FRONT

Engine Oil Dipstick Check Level

D

D

Cooling System Check Level/ Add

Transmission Fluid Dipstick Check Level

D

OC

Dexron III Transmission Fill Tube Add

Engine Crankcase Add

OE/ HDO or OEA

OC

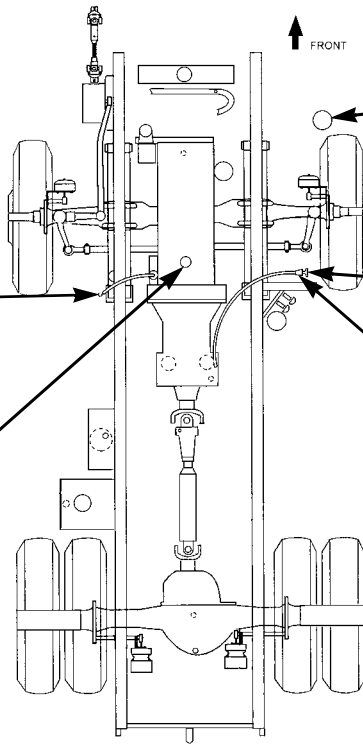

LUBRICANT • INTERVAL

M878A2

Fifth Wheel Plate,
Front of Throat,
and Locking Jaws

GAA M

Release Arm
Spring/Rod Cam
Pivot/Travel Path

OE/
HDO M

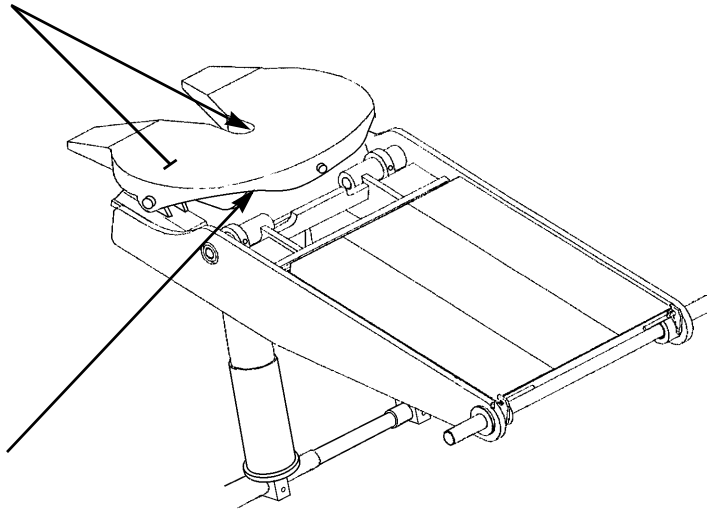

376-475

END OF WORK PACKAGE

Table 1. Preventive Maintenance Checks and Services (PMCS) for M878A2.

ITEM NO.	INTERVAL	LOCATION ITEM TO CHECK/ SERVICE	PROCEDURE	NOT FULLY MISSION CAPABLE IF:
1	Before	FRONT AND LEFT SIDE	<p style="text-align: center;">NOTE</p> <ul style="list-style-type: none"> • Review all WARNINGS, CAUTIONS, and NOTES before performing PMCS and operating the tractor. • Perform monthly PMCS checks if: <ul style="list-style-type: none"> a. You are the assigned operator but have not operated the tractor since the last monthly inspection. b. You are operating the tractor for the first time. 	
		Overall View	<p style="text-align: center;">NOTE</p> <p>If leakage is detected, further investigation is required to determine location and cause of leak.</p> <ul style="list-style-type: none"> a. Check under tractor for evidence of fluid leakage such as oil, hydraulic fluid, coolant or fuel. b. Check tractor for obvious damage that would impair operation. <p style="text-align: center;">WARNING</p> <p>Operating tractor with an underinflated or defective tire may lead to tire failure and loss of steering control. Injury to personnel or damage to equipment may result.</p> <p style="text-align: center;">NOTE</p> <p>Due to speed limitation of vehicle and its load capability, tire manufacturer has authorized a tire inflation of 120 psi (827 kPa).</p> <ul style="list-style-type: none"> c. Visually check tires for defects, underinflation or loose or missing wheel studs or wheel nuts. 	<ul style="list-style-type: none"> a. Class III oil, hydraulic fluid, coolant or fuel leaks are evident. b. Damage that would impair operation is evident. c. Tire is missing, deflated, unserviceable or two or more wheel studs or wheel nuts are missing.

Table 1. Preventive Maintenance Checks and Services (PMCS) for M878A2 - Continued.

ITEM NO.	INTERVAL	LOCATION	ITEM TO CHECK/SERVICE	PROCEDURE	NOT FULLY MISSION CAPABLE IF:
1 (Con't)	Before	Overall View	d. Visually check level of gear lubricating oil in front wheel hub sight glass. Oil must be level with FULL line on sight glass. If level is low, notify Unit Maintenance. e. Check for leaks of gear lubricating oil from rear axle wheel hub end. Notify Unit Maintenance if leaks are evident.	d. Oil is not visible in sight glass. e. Class III leaks are evident.	

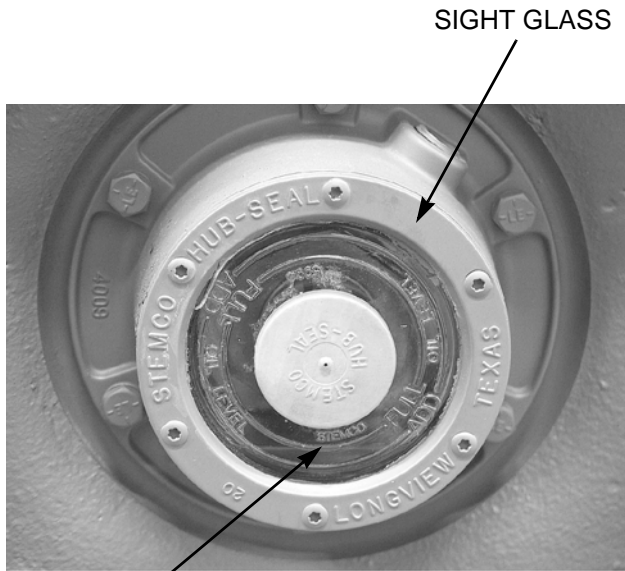

FULL LINE

FRONT AXLE

REAR AXLE

NOTE

Operation of vehicle with damaged or missing windshield or wiper arm/blade may violate AR 385-55.

2	Before	Cab Exterior	a. Check for damage to lights, spotting mirror, side mirror, windshield, windshield wiper and blade, cab door, grabhandles, and battery box and steps. b. Ensure that cover is installed on NATO slave receptacle.	a. Damage that would interfere with visibility and impair operation is evident.
3	Before	Cab Tilt Latch	Check that left-rear corner of cab is securely latched. Plunger button on side of latching mechanism should be depressed.	Cab is not latched.

Table 1. Preventive Maintenance Checks and Services (PMCS) for M878A2 - Continued.

ITEM NO.	INTERVAL	LOCATION	ITEM TO CHECK/ SERVICE	PROCEDURE	NOT FULLY MISSION CAPABLE IF:
3 (Con't)	Before	Cab Tilt Latch			
376-021					
4	Before	REAR AND RIGHT SIDE	Overall View	<p>a. Check under tractor for evidence of fluid leakage such as oil, hydraulic fluid, coolant or fuel.</p> <p style="text-align: center;">NOTE</p> <p>If leakage is detected, further investigation is required to determine location and cause of leak.</p> <p>b. Check tractor for obvious damage that would impair operation.</p>	<p>a. Class III oil, hydraulic fluid, coolant or fuel leaks are evident.</p> <p>b. Damage that would impair operation is evident.</p>

Table 1. Preventive Maintenance Checks and Services (PMCS) for M878A2 - Continued.



ITEM NO.	INTERVAL	LOCATION	PROCEDURE	NOT FULLY MISSION CAPABLE IF:
4 (Con't)	Before	Overall View	<p style="text-align: center;">WARNING</p> <p>Operating tractor with an underinflated or defective tire may lead to tire failure and loss of steering control. Injury to personnel or damage to equipment may result.</p> <p style="text-align: center;">NOTE</p> <p>Due to speed limitation of vehicle and its load capability, tire manufacturer has authorized a tire inflation of 120 psi (827 kPa).</p> <p>c. Check tires for defects, underinflation or loose or missing wheel studs or wheel nuts.</p> <p>d. Visually check level of gear lubricating oil in front wheel hub sight glass. Oil must be level with FULL line on sight glass. If level is low, notify Unit Maintenance.</p> <p>e. Check for leaks of gear lubricating oil from rear axle wheel hub end. Notify Unit Maintenance if leaks are evident.</p>	<p>c. Tire is missing, deflated, unserviceable or two or more wheel studs or wheel nuts are missing.</p> <p>d. Oil is not visible in sight glass.</p> <p>e. Class III leaks are evident.</p>
<div style="display: flex; justify-content: space-around; align-items: flex-start;"> <div style="text-align: center;"> <p>SIGHT GLASS</p>  <p>FULL LINE</p> <p>FRONT AXLE</p> </div> <div style="text-align: center;"> <p>CHECK FOR LEAKS</p>  <p>REAR AXLE</p> </div> </div>				
5	Before	Cab Exterior	Check for damage to lights, rear cab door, grabhandles, intervehicular air lines, fuel tank and steps, spotter mirror, and side mirror.	Damage that would interfere with visibility and impair operation is evident.

Table 1. Preventive Maintenance Checks and Services (PMCS) for M878A2 - Continued.

ITEM NO.	INTERVAL	LOCATION	ITEM TO CHECK/SERVICE	PROCEDURE	NOT FULLY MISSION CAPABLE IF:
6	Before	Transmission Fluid Level		<p>CAUTION</p> <p>DO NOT start engine until sufficient transmission fluid has been confirmed.</p> <p>Remove transmission dipstick and ensure static fluid level is near HOT FULL mark.</p>	<p>Class III leaks are evident. Fluid level is not near HOT FULL mark.</p>
 <p style="text-align: right; margin-right: 100px;">DIPSTICK</p> <p style="text-align: right; margin-right: 100px;">376-070</p>					
7	Before	<p>CAB INTERIOR</p> <p>Instrument Panel</p>		<p>NOTE</p> <p>Refer to WP 0004 00 for the location of all gauges, switches, and indicator and warning lights.</p> <p>Check for damage to gauges, switches, and indicator and warning lights.</p>	<p>Any gauge/indicator and warning light is broken or unreadable.</p>

Table 1. Preventive Maintenance Checks and Services (PMCS) for M878A2 - Continued.

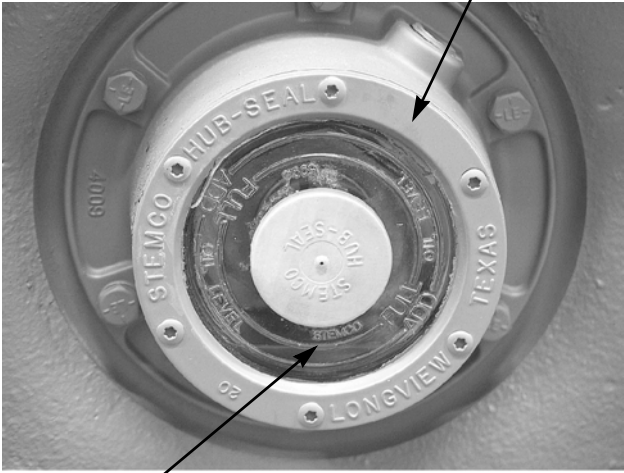
ITEM NO.	INTERVAL	LOCATION ITEM TO CHECK/ SERVICE	PROCEDURE	NOT FULLY MISSION CAPABLE IF:
8	Before	Fire Extinguisher	a. Check for missing or damaged fire extinguisher. b. Check gauge for proper pressure. Gauge needle should be in green area on gauge. c. Check for broken or missing seal.	a. Fire extinguisher is missing or damaged. b. Pressure gauge needle is in red area. c. Seal is broken or missing.

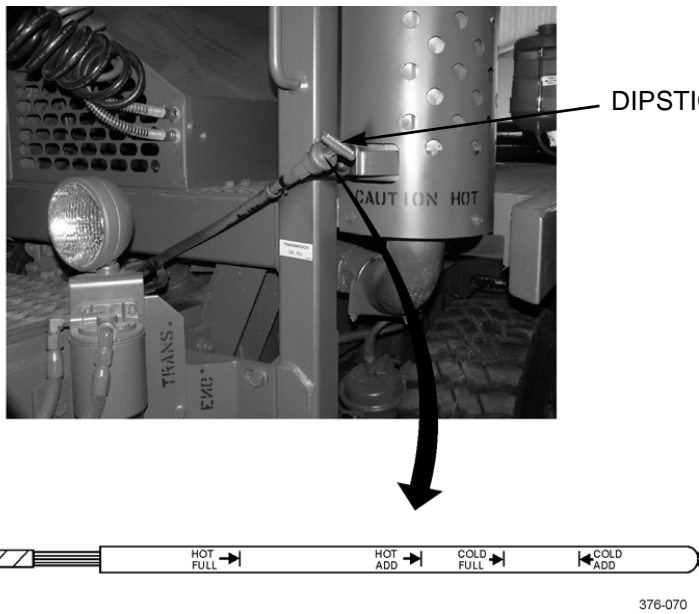
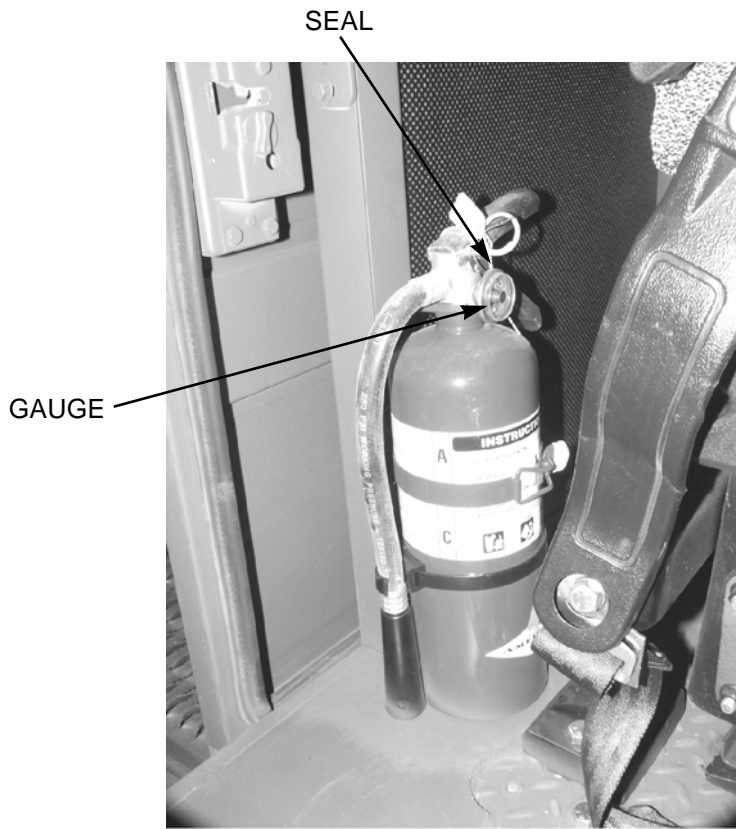

376-023

9	Before	Engine Startup	<p style="text-align: center;">CAUTION</p> <p>After engine is started, all warning lights should go out in approximately 15 seconds. If warning lights do not go out, shut down engine and investigate cause. Failure to follow this caution may damage engine.</p> a. Start engine (WP 0005 00). Verify that LOW AIR warning light and buzzer come on.	a. Engine will not start. LOW AIR warning light and buzzer do not come on.
---	--------	----------------	--	--

Table 1. Preventive Maintenance Checks and Services (PMCS) for M878A2 - Continued.

ITEM NO.	INTERVAL	LOCATION ITEM TO CHECK/ SERVICE	PROCEDURE	NOT FULLY MISSION CAPABLE IF:
9 (Con't)	Before	Engine Startup	b. Check that high water temperature/low oil pressure (HIGH WATER LOW OIL) warning light goes out within 15 seconds. c. Check that LOW AIR warning light and buzzer turn off when air pressure on gauge reaches 65 psi (448 kPa). d. Check air cleaner restriction indicator. If yellow band has risen to red area on gauge, service air cleaner (WP 0015 00). e. Check operation of lights.	b. Warning light stays on. c. LOW AIR warning light and buzzer remain on. d. Yellow band has risen to red area on gauge.
10	Before	RIGHT SIDE Transmission Fluid Level	<p style="text-align: center;">NOTE</p> Vehicle operation with inoperative horn may violate AR 385-55. f. If tactical situation permits, check operation of horn.	<p style="text-align: center;">NOTE</p> A COLD RUN check is made when transmission fluid is at an ambient temperature of 32-110 degrees F (0-38 degrees C). Perform COLD RUN check: Class III leaks are evident. Fluid level is not within COLD RUN band.
			a. Ensure tractor is parked on level surface, with wheels chocked, and parking brake applied. b. Run engine at idle (500-800 rpm) for about one minute. Shift to D (Drive) and then to R (Reverse) to clear hydraulic circuits of air. Then shift to N (Neutral) and allow engine to remain at idle (500-800 rpm).	

Table 1. Preventive Maintenance Checks and Services (PMCS) for M878A2 - Continued.



ITEM NO.	INTERVAL	LOCATION ITEM TO CHECK/ SERVICE	PROCEDURE	NOT FULLY MISSION CAPABLE IF:
10 (Con't)	Before	Transmission Fluid Level	c. With engine running, remove dipstick from tube and wipe clean.	
<div style="display: flex; justify-content: space-around; align-items: center;"> <div style="text-align: center;"> <p>FILL TUBE</p>  </div> <div style="text-align: center;"> <p>DIPSTICK</p> </div> </div> <div style="text-align: center; margin-top: 20px;">  </div> <p style="text-align: right; margin-right: 50px;">376-070</p>				
			<p>d. Insert dipstick into tube and remove. Check fluid level. Repeat check procedure to verify reading.</p> <p>e. If fluid level is within COLD RUN band, transmission can be operated until fluid is hot enough to perform a HOT RUN check. If fluid level is not within COLD RUN band, add or drain transmission fluid (Item 6, WP 0019 00) as necessary to bring fluid level to middle of COLD RUN band.</p> <p>f. Perform a HOT RUN check after transmission has been operated under load for at least one hour and engine coolant temperature of 190-215 degrees F (88-102 degrees C) is reached.</p>	

Table 1. Preventive Maintenance Checks and Services (PMCS) for M878A2 - Continued.

ITEM NO.	INTERVAL	LOCATION ITEM TO CHECK/ SERVICE	PROCEDURE	NOT FULLY MISSION CAPABLE IF:
11	Before	CAB INTERIOR Instrument Panel Gauges and Indicator and Warning Lights	a. Check oil pressure gauge to ensure it indicates within operating range (GREEN area on gauge). Minimum oil pressure is 15 psi (103 kPa). b. Check air pressure gauge. NOTE If voltmeter registers in RED or YELLOW band, perform electrical troubleshooting (WP 0009 00). c. Check that voltmeter registers within GREEN (center) band. d. Check that fuel gauge registers and indicates adequate fuel for mission.	a. Gauge reading is not within limits. b. Gauge reads less than 65 psi (448 kPa), LOW AIR warning light stays on or gauge is not operating.
12	Before	Seat and Seat Belt	a. Check seat and seat belt for security of mounting and damage.	a. Seat belt is not serviceable. NOTE All adjustments should be made while seated. Air pressure gauge must indicate a minimum of 60 psi (414 kPa) to adjust height of seat.
13	Before	Side Mirrors and Spotter Mirrors	b. Adjust seat (WP 0004 00). Adjust mirrors as required.	b. Seat is missing or inoperative.
14	Before	Parking Brake	Depress service brake pedal. With transmission in D (Drive), engine at idle, and parking brake control pulled out (parking brake applied), release service brake pedal. Vehicle should not move.	Vehicle moves with parking brake applied.
15	Before	Service Brakes	With parking brake and service brakes applied, place transmission in D (Drive). Release parking brake. Vehicle should not move.	Vehicle moves with service brakes applied.
16	Before	Fifth Wheel	Perform a functional check of fifth wheel lift (WP 0005 00).	Fifth wheel will not raise or lower.

Table 1. Preventive Maintenance Checks and Services (PMCS) for M878A2 - Continued.

ITEM NO.	INTERVAL	LOCATION ITEM TO CHECK/ SERVICE	PROCEDURE	NOT FULLY MISSION CAPABLE IF:		
17	During	Trailer Brakes	<p style="text-align: center;">NOTE</p> <p>Perform this check with trailer after tractor/trailer combination is coupled.</p> <table border="0" style="width: 100%;"> <tr> <td style="width: 50%; vertical-align: top;"> a. Listen for air leaks at intervehicular connecting hoses, relay valve, and air reservoirs. b. Apply trailer brakes only and attempt to move tractor/trailer combination. </td> <td style="width: 50%; vertical-align: top;"> a. Any air leaks are present. b. Brakes fail to hold tractor/trailer combination from moving. </td> </tr> </table>		a. Listen for air leaks at intervehicular connecting hoses, relay valve, and air reservoirs. b. Apply trailer brakes only and attempt to move tractor/trailer combination.	a. Any air leaks are present. b. Brakes fail to hold tractor/trailer combination from moving.
a. Listen for air leaks at intervehicular connecting hoses, relay valve, and air reservoirs. b. Apply trailer brakes only and attempt to move tractor/trailer combination.	a. Any air leaks are present. b. Brakes fail to hold tractor/trailer combination from moving.					
18	During	Instrument Panel Displays	<p>Monitor all gauges and indicator and warning lights. Check that all gauges register within normal range (WP 0004 00).</p>			
19	During	Brakes	<table border="0" style="width: 100%;"> <tr> <td style="width: 50%; vertical-align: top;"> a. Check brakes for pulling or grabbing. b. Check that brake pedal is firm and does not fully depress to floor. </td> <td style="width: 50%; vertical-align: top;"> a. Brakes pull or grab. b. Brake pedal is spongy or depresses fully to floor. </td> </tr> </table>		a. Check brakes for pulling or grabbing. b. Check that brake pedal is firm and does not fully depress to floor.	a. Brakes pull or grab. b. Brake pedal is spongy or depresses fully to floor.
a. Check brakes for pulling or grabbing. b. Check that brake pedal is firm and does not fully depress to floor.	a. Brakes pull or grab. b. Brake pedal is spongy or depresses fully to floor.					
20	During	Steering	<p>Check for smooth steering without pulling to one side or excessive play in steering wheel.</p> <p>Steering is erratic, pulls or has excessive play.</p>			
21	During	Power Train	<p>Check for unusual noise or vibration from engine, transmission, drive shaft, axles, and wheels.</p>			
22	During	Air Conditioner	<p style="text-align: center;">NOTE</p> <p>Perform the following inspection only if air conditioner is required due to climatic conditions.</p> <p>Turn air conditioner on and set blower to maximum cooling speed settings (WP 0005 00). Wait five minutes to allow temperature to stabilize. Check outlet ducts for cool air. If air is not cooler than ambient temperature, notify supervisor.</p>			
23	During	Overall Leakage	<p style="text-align: center;">NOTE</p> <p>If leakage is detected, further investigation is required to determine location and cause of leak.</p> <table border="0" style="width: 100%;"> <tr> <td style="width: 50%; vertical-align: top;"> Be alert for evidence of fluid leakage. </td> <td style="width: 50%; vertical-align: top;"> Class III oil, hydraulic fluid, coolant or fuel leaks are evident. </td> </tr> </table>		Be alert for evidence of fluid leakage.	Class III oil, hydraulic fluid, coolant or fuel leaks are evident.
Be alert for evidence of fluid leakage.	Class III oil, hydraulic fluid, coolant or fuel leaks are evident.					

Table 1. Preventive Maintenance Checks and Services (PMCS) for M878A2 - Continued.

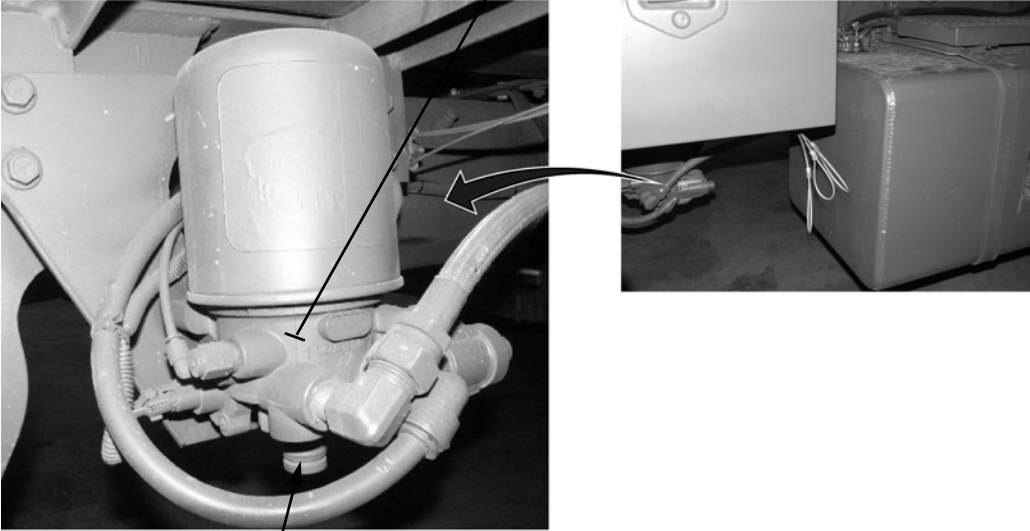
ITEM NO.	INTERVAL	LOCATION ITEM TO CHECK/ SERVICE	PROCEDURE	NOT FULLY MISSION CAPABLE IF:
24	After	<p style="text-align: center;">RIGHT SIDE</p> <p>Air Dryer</p>	<p>a. Check exhaust port of air dryer for obstructions such as mud or debris.</p>	
 <p>AIR DRYER</p> <p>EXHAUST PORT</p>				
			<p>b. With engine running, pump service brakes until dual air pressure gauge drops below 100 psi (690 kPa).</p> <p>c. Allow air pressure to build in air system until dual air pressure gauge indicates approximately 125 psi (862 kPa).</p> <p>d. At approximately 125 psi, sound of exhausting moisture from air dryer exhaust port (purge valve) should be heard. Green needle on dual air pressure gauge will begin to drop, until it has dropped 10 psi (69 kPa).</p> <p>e. Notify Unit Maintenance if moisture ejection is inoperative.</p>	<p>e. Air dryer moisture ejection (purge cycle) does not operate.</p>

376-657

Table 1. Preventive Maintenance Checks and Services (PMCS) for M878A2 - Continued.

ITEM NO.	INTERVAL	LOCATION ITEM TO CHECK/ SERVICE	PROCEDURE	NOT FULLY MISSION CAPABLE IF:
25	After	Transmission Fluid Level	<p style="text-align: center;">NOTE</p> <p>Perform a HOT RUN transmission fluid check after vehicle operation, when transmission has been operated under load for at least one hour and engine coolant temperature is at normal operating temperature of 190-215 degrees F (88-102 degrees C).</p> <p>Perform HOT RUN check:</p> <ol style="list-style-type: none"> a. Park tractor on level surface, chock wheels, shift transmission to N (Neutral), and apply parking brake. b. Run engine at idle (500-800 rpm). Shift transmission to D (Drive) and then to R (Reverse) to clear hydraulic circuits of air. Shift to N (Neutral) and leave engine at idle (500-800 rpm). c. Remove dipstick from tube and wipe clean. d. Insert dipstick into tube and remove. Check fluid level. Repeat check procedure to verify reading. e. Safe operating level is anywhere within HOT RUN band. f. If fluid level is not within HOT RUN band, add or drain transmission fluid (Item 6, WP 0019 00) as necessary to bring fluid level to middle of HOT RUN band. g. Shut down engine (WP 0005 00). 	

Table 1. Preventive Maintenance Checks and Services (PMCS) for M878A2 - Continued.



ITEM NO.	INTERVAL	LOCATION ITEM TO CHECK/ SERVICE	PROCEDURE	NOT FULLY MISSION CAPABLE IF:
25 (Con't)	After	Transmission Fluid Level		
<div style="display: flex; justify-content: space-between; align-items: center;"> <div style="text-align: center;"> <p>FILL TUBE</p>  </div> <div style="text-align: center;"> <p>DIPSTICK</p> </div> </div> <div style="text-align: center; margin-top: 20px;">  </div> <div style="text-align: right; margin-top: 10px;"> <p>376-070</p> </div>				
26	After	FRONT AND LEFT SIDE	<p style="text-align: center;">NOTE</p> <p>If leakage is detected, further investigation is required to determine location and cause of leak.</p> <p>a. Check under tractor for evidence of fluid leakage such as oil, hydraulic fluid, coolant or fuel.</p> <p>b. Check front gladhands for damage. Ensure that dummy couplings are installed.</p> <p>c. Check tractor for obvious damage that would impair operation.</p> <p>d. Check for damage to headlights, auxiliary lights, turn signals, and marker clearance lights.</p>	<p>a. Class III oil, hydraulic fluid, coolant or fuel leaks are evident.</p> <p>c. Damage that would impair operation is evident.</p>
		Overall View		

Table 1. Preventive Maintenance Checks and Services (PMCS) for M878A2 - Continued.

ITEM NO.	INTERVAL	LOCATION ITEM TO CHECK/ SERVICE	PROCEDURE	NOT FULLY MISSION CAPABLE IF:
27	After	Windshield Washer Reservoir	Remove cap and check level of fluid in windshield washer reservoir, mounted behind left side of front bumper. Add windshield cleaning compound (Item 4, WP 0019 00) as required. Install cap.	
 <p data-bbox="1094 1262 1154 1276">376-030</p>				
28	After	Wheels, Tires, and Mudflaps	<p data-bbox="954 1297 1133 1329" style="text-align: center;">WARNING</p> <p data-bbox="651 1346 1442 1440">Operating tractor with an underinflated or defective tire may lead to tire failure and loss of steering control. Injury to personnel or damage to equipment may result.</p> <p data-bbox="995 1451 1094 1482" style="text-align: center;">NOTE</p> <p data-bbox="651 1499 1442 1560">Due to speed limitation of vehicle and its load capability, tire manufacturer has authorized a tire inflation of 120 psi (827 kPa).</p> <p data-bbox="621 1570 1040 1738"> a. Visually check tires for defects, underinflation or loose or missing wheel studs or wheel nuts. b. Check for presence and general condition of mudflaps. </p>	<p data-bbox="1052 1570 1471 1665">a. Tire is missing, deflated, unserviceable or two or more wheel studs or wheel nuts are missing.</p>

Table 1. Preventive Maintenance Checks and Services (PMCS) for M878A2 - Continued.

ITEM NO.	INTERVAL	LOCATION ITEM TO CHECK/ SERVICE	PROCEDURE	NOT FULLY MISSION CAPABLE IF:
29	After	Hydraulic Reservoir	a. Check hydraulic filter, reservoir, and hydraulic hoses for damage and leaks. b. With fifth wheel fully lowered, check level of hydraulic fluid at hydraulic reservoir sight gauge. Fluid should be level with FULL line stenciled on reservoir. Add hydraulic fluid (Item 7 or 8, WP 0019 00) as required through filler opening at top of reservoir. Level must not exceed line stenciled on reservoir.	a. Class III leaks are evident. b. Class III leaks are evident.

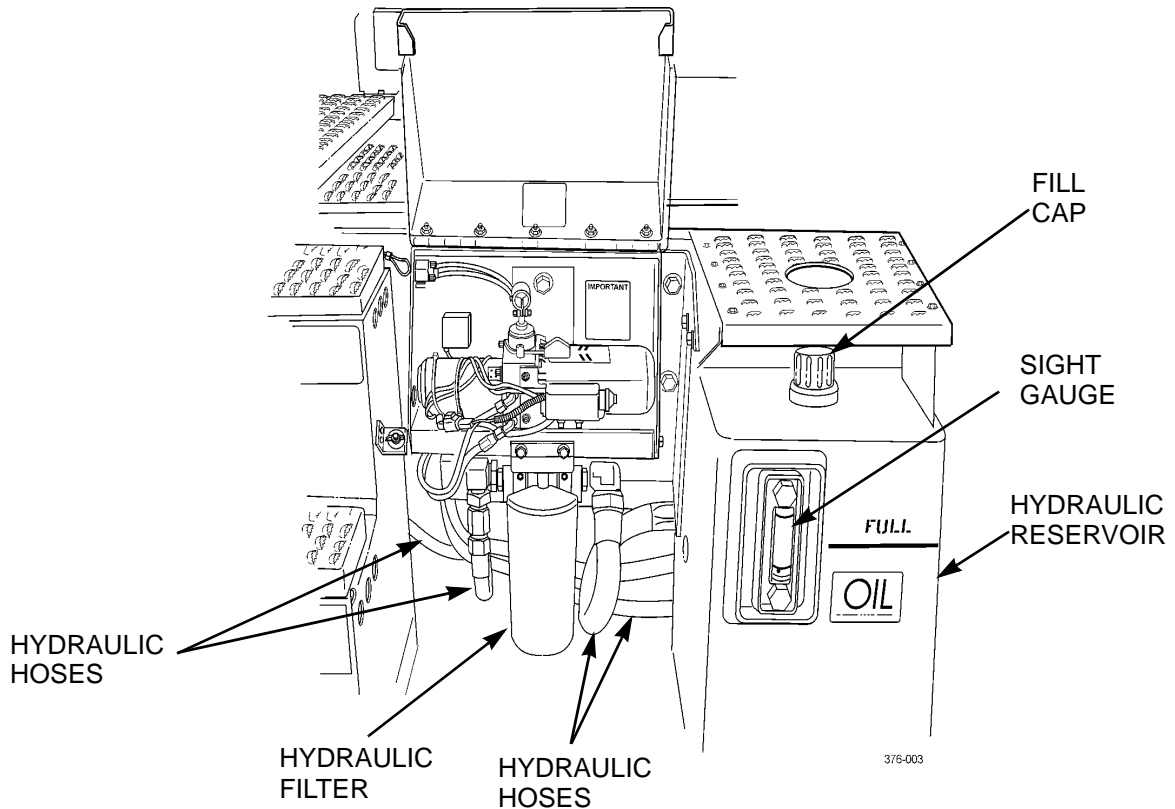

Table 1. Preventive Maintenance Checks and Services (PMCS) for M878A2 - Continued.

ITEM NO.	INTERVAL	LOCATION ITEM TO CHECK/ SERVICE	PROCEDURE	NOT FULLY MISSION CAPABLE IF:
30	After	REAR AND RIGHT SIDE	a. Check under tractor for evidence of fluid leakage such as oil, hydraulic fluid, coolant or fuel. b. Check tractor for obvious damage that would impair operation. c. Check rear gladhands for damage. Ensure that dummy couplings are installed. d. Check for damage to floodlights, strobe warning light, backup light, and taillights. e. Check for damage to exhaust system components. Ensure that components are securely mounted and are not leaking.	a. Class III oil, hydraulic fluid, coolant or fuel leaks are evident. b. Damage that would impair operation is evident. e. Any exhaust system leaks are evident.
		Overall View		
31	After	Fifth Wheel	a. Check top plate for severe wear, chips, cracks, gouges or bends.	b. Latching cylinder or air hose is loose or damaged. Locking jaw mechanism is cracked or worn.

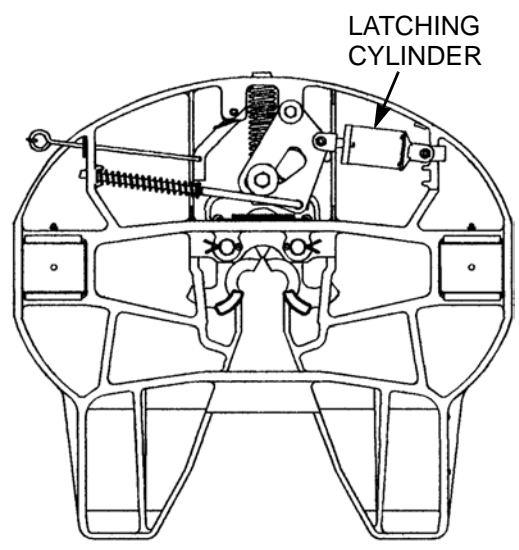
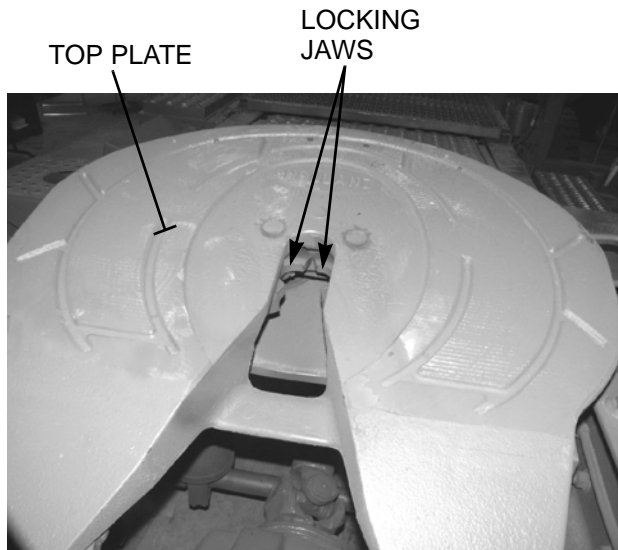

Table 1. Preventive Maintenance Checks and Services (PMCS) for M878A2 - Continued.

ITEM NO.	INTERVAL	LOCATION ITEM TO CHECK/ SERVICE	PROCEDURE	NOT FULLY MISSION CAPABLE IF:
32	After	Wheels, Tires, and Mudflaps	<p>WARNING</p> <p>Operating tractor with an underinflated or defective tire may lead to tire failure and loss of steering control. Injury to personnel or damage to equipment may result.</p> <p>NOTE</p> <p>Due to speed limitation of vehicle and its load capability, tire manufacturer has authorized a tire inflation of 120 psi (827 kPa).</p> <p>a. Check tires for defects, underinflation or loose wheel studs or wheel nuts.</p> <p>b. Check for presence and general condition of mudflaps.</p>	<p>a. Tire is missing, deflated, unserviceable or two or more wheel studs or wheel nuts are missing.</p>
33	After	Stowage Compartment	<p>a. Check for damage and secure mounting of stowage compartment.</p> <p>b. Verify that BII items are stowed inside stowage compartment (WP 0017 00).</p>	
34	After	Intervehicular Air Hoses and Electrical Cables and Receptacle Connectors	<p>Check for presence and general condition of intervehicular air hoses, gladhands, gladhand preformed packings, intervehicular electrical cables, and electrical receptacle connectors.</p>	<p>Damage in air lines is noted that will cause air leaks. Electrical cable or receptacle connector is damaged.</p>

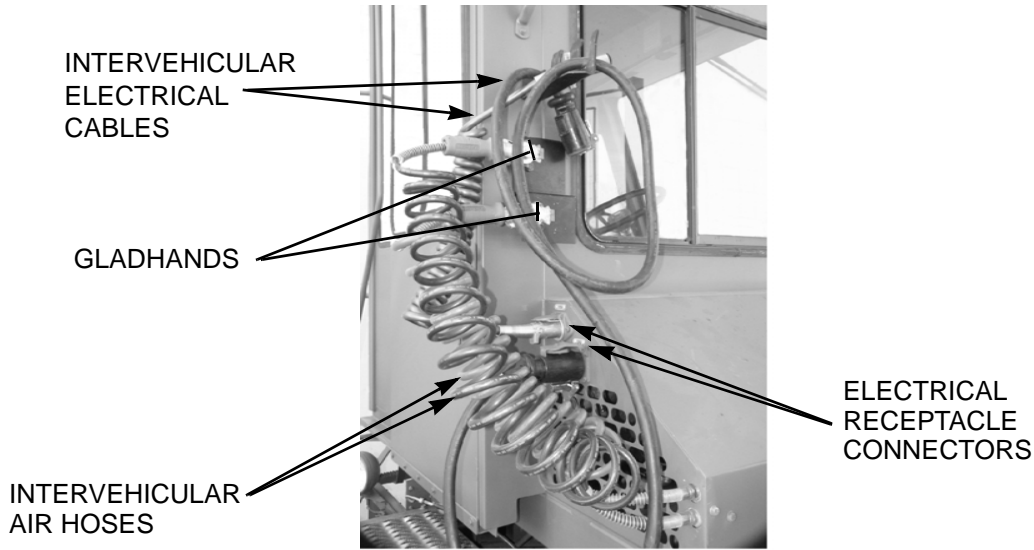



Table 1. Preventive Maintenance Checks and Services (PMCS) for M878A2 - Continued.

ITEM NO.	INTERVAL	LOCATION ITEM TO CHECK/ SERVICE	PROCEDURE	NOT FULLY MISSION CAPABLE IF:
35	After	Fuel Tank	 <p>WARNING</p> <ul style="list-style-type: none"> • DO NOT smoke or permit any open flame in area of tractor while servicing diesel fuel system. Be sure hose nozzle is grounded against filler tube during refueling to prevent static electricity. Failure to follow this warning may result in injury to personnel or equipment damage. • Wear fuel-resistant gloves when handling fuels and promptly wash exposed skin and change fuel-soaked clothing. <p>a. Check for presence and condition of fuel filler cap.</p> <p>b. Check fuel tank for leaks, damage, and security of mounting.</p> <p>c. Remove fuel tank filler cap. Add fuel (Item 9, WP 0019 00) to fuel tank to level stenciled on outside of tank (WP 0013 00).</p>	<p>a. Filler cap is missing or damaged.</p> <p>b. Class III fuel leaks are evident.</p>

FILLER CAP



376-653

Table 1. Preventive Maintenance Checks and Services (PMCS) for M878A2 - Continued.

ITEM NO.	INTERVAL	LOCATION ITEM TO CHECK/ SERVICE	PROCEDURE	NOT FULLY MISSION CAPABLE IF:
36	After	Fuel/Water Separator	<div data-bbox="764 453 924 596" style="text-align: center;"> </div> <p data-bbox="954 558 1133 590" style="text-align: center;">WARNING</p> <ul data-bbox="643 611 1451 768" style="list-style-type: none"> • DO NOT perform fuel system checks, inspections or maintenance while smoking or near fire, flames or sparks. Fuel may ignite, causing injury or death to personnel and damage to vehicle. • Wear fuel-resistant gloves when handling fuels and promptly wash exposed skin and change fuel-soaked clothing. <p data-bbox="993 783 1094 814" style="text-align: center;">NOTE</p> <p data-bbox="760 831 1328 863" style="text-align: center;">Ensure that a suitable container is used to catch fluid.</p> <p data-bbox="621 873 1040 995">If water or sediment is visible, turn drain knob clockwise to drain all water from sediment bowl. Turn knob counterclockwise to close.</p>	

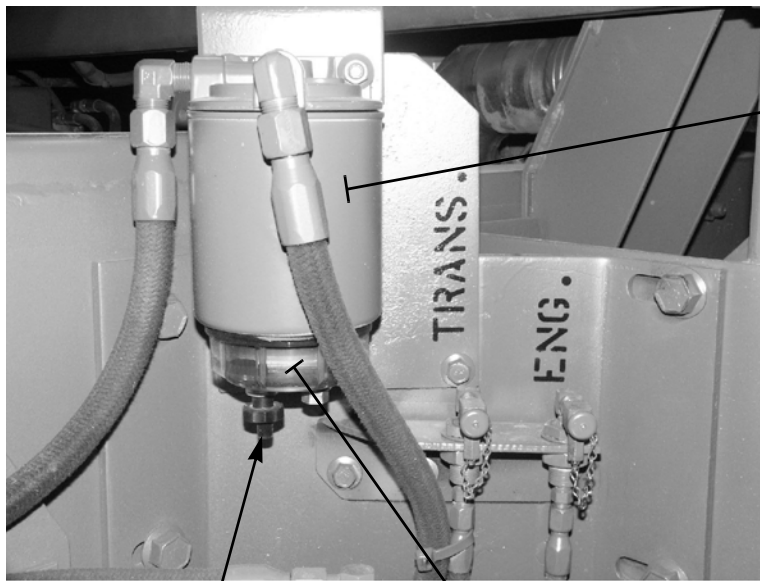

PRIMARY FUEL FILTER

DRAIN KNOB

SEDIMENT BOWL

376-028

Table 1. Preventive Maintenance Checks and Services (PMCS) for M878A2 - Continued.

ITEM NO.	INTERVAL	LOCATION ITEM TO CHECK/ SERVICE	PROCEDURE	NOT FULLY MISSION CAPABLE IF:
37	After	Coolant Over-flow Bottle	Check coolant level in coolant overflow bottle. Level should be at FULL COLD mark on sight glass, with engine cold. If level is low, remove cap and add a 50/50 mixture of antifreeze (Item 1, WP 0019 00) and water to bring level up to line on sight glass. In temperatures below -34°F (-37°C)], use a 60/40 mixture of antifreeze and water. DO NOT overfill. Reinstall cap on bottle.	
<div style="text-align: center;">  <p style="text-align: right; margin-right: 50px;">376-026</p> </div>				

Table 1. Preventive Maintenance Checks and Services (PMCS) for M878A2 - Continued.

ITEM NO.	INTERVAL	LOCATION ITEM TO CHECK/ SERVICE	PROCEDURE	NOT FULLY MISSION CAPABLE IF:
38	After	Air System Drain	<p align="center">NOTE</p> <p align="center">Perform the following service for all three air reservoirs.</p> <p>Open each air reservoir drain valve, using cable pull, and allow all air and condensation to drain. When fully drained, release cable pull to close drain valve.</p>	
				
CABLE PULLS				
39	After	Air Intake Tubes and Hoses	Tilt cab (WP 0005 00). Check air intake tubes and hoses for cracks, tears or leaks.	Tubes or hoses are cracked, torn or leaks are evident.
				

Table 1. Preventive Maintenance Checks and Services (PMCS) for M878A2 - Continued.

ITEM NO.	INTERVAL	LOCATION	PROCEDURE	NOT FULLY MISSION CAPABLE IF:
40	After	LEFT SIDE	<p style="text-align: center;">NOTE</p> <p>To ensure an accurate reading, vehicle must be parked on level ground. Wait 10 minutes after shutting down engine to allow oil to drain into crankcase.</p> <p>Check engine oil level with vehicle parked on a level surface:</p> <ol style="list-style-type: none"> a. Remove dipstick, wipe clean, then reinstall. b. Remove dipstick and check level. Level should be within cross-hatched area (OPERATING RANGE) on dipstick. 	
		Engine Oil Level		

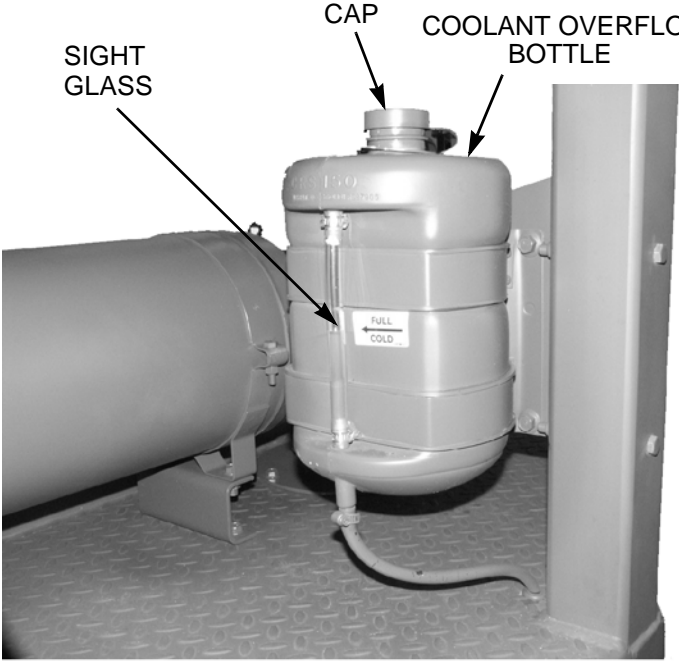

DIPSTICK

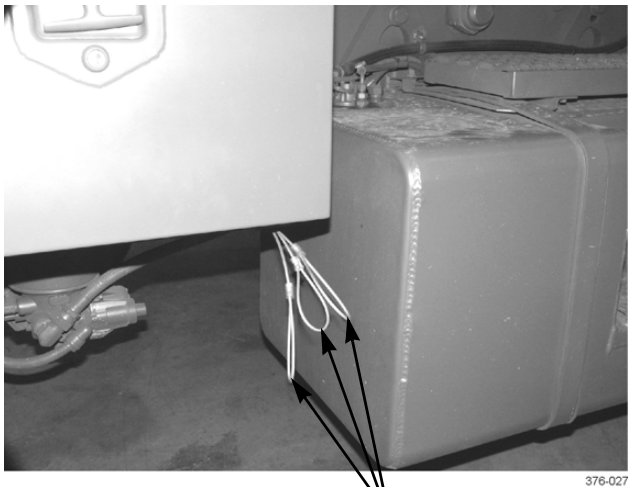
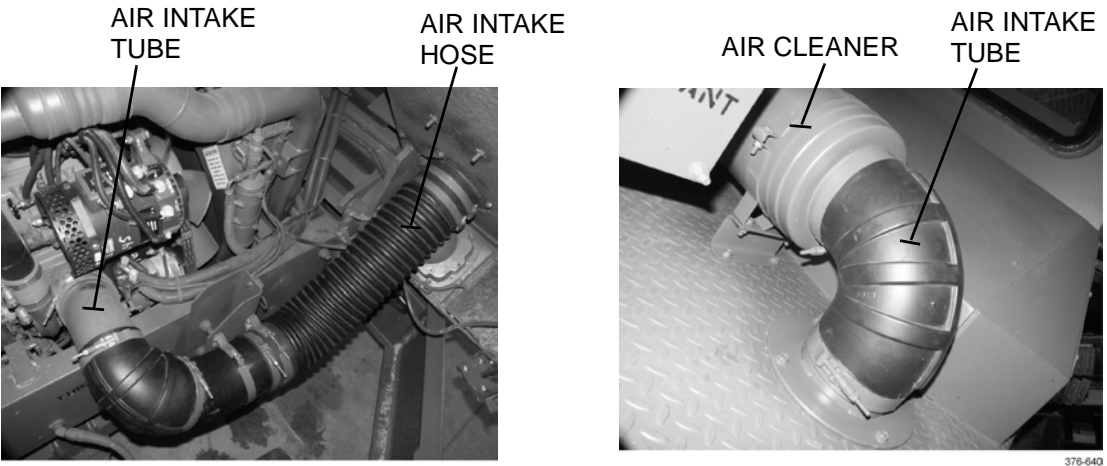
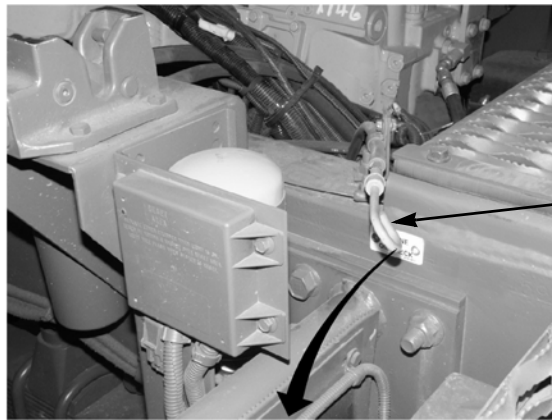

376-062

Table 1. Preventive Maintenance Checks and Services (PMCS) for M878A2 - Continued.

ITEM NO.	INTERVAL	LOCATION ITEM TO CHECK/ SERVICE	PROCEDURE	NOT FULLY MISSION CAPABLE IF:
40 (Con't)	After	Engine Oil Level	c. If level is at or below ADD line on dipstick, add engine oil (Item 11, 13 or 14, WP 0019 00) through filler opening until level on dipstick is correct.	
				
376-039				
41	After	CAB INTERIOR Accessory Items	d. Lower cab (WP 0005 00). Start engine and verify operation of windshield wiper and windshield washer, heater/ventilator, and air conditioner (WP 0005 00).	
42	After	Lights	NOTE Vehicle operation with damaged or inoperative headlights or stoplights may violate AR 385-55. Check operation of headlights, turn signals, strobe warning light, floodlights, backup light, taillights, marker clearance lights, and auxiliary lights (WP 0005 00).	
43	After	Air Cleaner Restriction Indicator	a. Check air cleaner restriction indicator. If yellow band has risen to red area on gauge, service engine air cleaner (WP 0015 00). b. Shut down engine (WP 0005 00).	Yellow band has risen to red area on gauge.

Table 1. Preventive Maintenance Checks and Services (PMCS) for M878A2 - Continued.

ITEM NO.	INTERVAL	LOCATION ITEM TO CHECK/ SERVICE	PROCEDURE	NOT FULLY MISSION CAPABLE IF:
44	Monthly	FRONT AND LEFT SIDE Cab Tilt System	a. Raise cover and check for damage or leaks to cab tilt pump, pump controls, and hydraulic hoses. b. Ensure that safety prop release cable is present, secure, and in good condition.	a. Pump, pump controls or hydraulic hoses are damaged. Class III leaks are evident. b. Cable is missing or damaged.



c. Tilt cab (WP 0005 00).

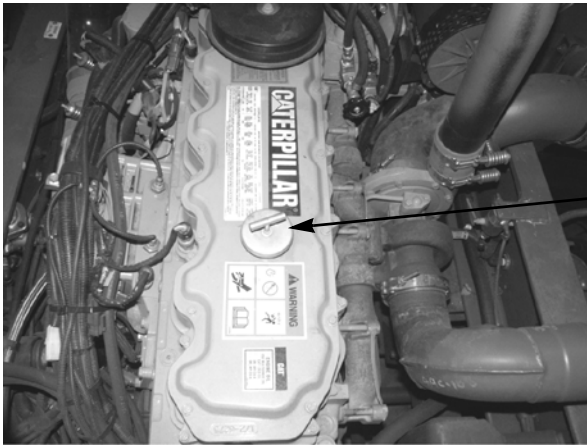
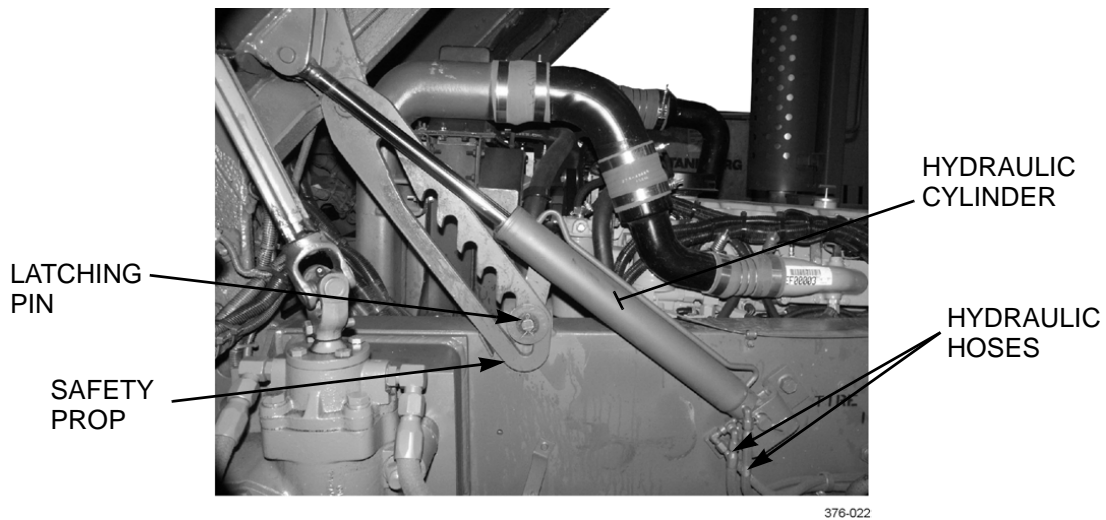
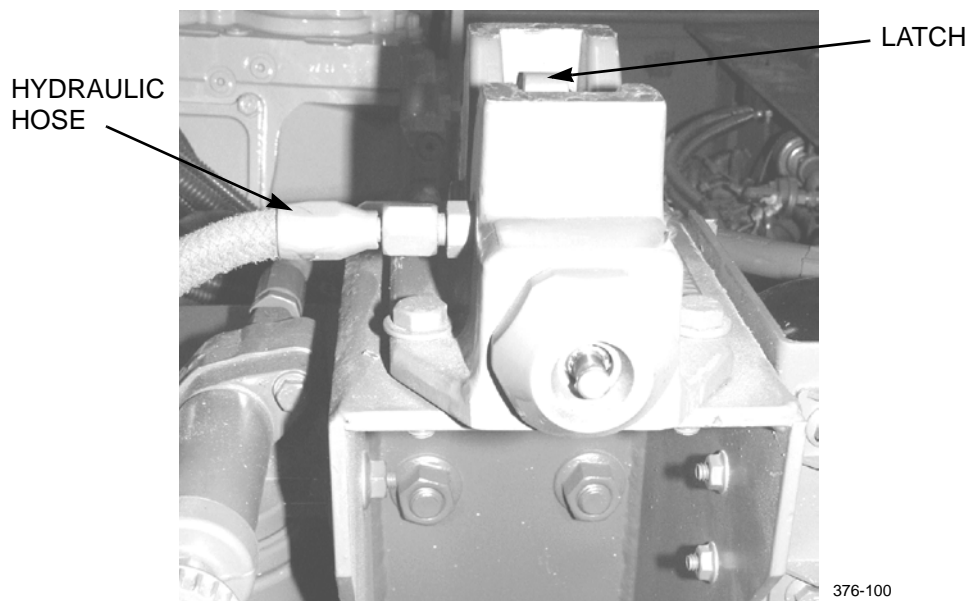

Table 1. Preventive Maintenance Checks and Services (PMCS) for M878A2 - Continued.

ITEM NO.	INTERVAL	LOCATION ITEM TO CHECK/ SERVICE	PROCEDURE	NOT FULLY MISSION CAPABLE IF:
44 (Con't)	Monthly	Cab Tilt System	d. Check safety prop for secure mounting and presence and condition of latching pin. e. Check hydraulic cylinder for secure mounting and hoses for leaks. f. Check cab tilt latch for secure mounting and hydraulic hose for leaks.	e. Class III leaks are evident. f. Class III leaks are evident.

Table 1. Preventive Maintenance Checks and Services (PMCS) for M878A2 - Continued.

ITEM NO.	INTERVAL	LOCATION ITEM TO CHECK/ SERVICE	PROCEDURE	NOT FULLY MISSION CAPABLE IF:
45	Monthly	Serpentine Drive Belt	a. Check for loose, missing, glazed, torn, frayed or cracked serpentine drive belt. Notify Unit Maintenance if loose belt is suspected. b. Check for damaged pulleys.	a. Belt is loose, missing, glazed or damaged. b. Pulley is damaged.
				
46	Monthly	Engine Components	Check for evidence of damage or leaks to engine components. Notify Unit Maintenance if damage or leaks are evident.	
46.1	Monthly	Radiator	Remove dirt and debris from cooling fins.	

Table 1. Preventive Maintenance Checks and Services (PMCS) for M878A2 - Continued.



ITEM NO.	INTERVAL	LOCATION ITEM TO CHECK/ SERVICE	PROCEDURE	NOT FULLY MISSION CAPABLE IF:
47	Monthly	Ether Cold Start System	<div style="text-align: center;">  <p>WARNING</p> </div> <p>Ether fuel is extremely flammable and toxic. DO NOT smoke and make sure you are in a well-ventilated area away from heat, open flames or sparks. Wear eye protection. Avoid contact with skin and eyes and avoid breathing ether fumes. If fluid enters or fumes irritate the eyes, wash immediately with large quantities of clean water for 15 minutes. Seek medical attention immediately if ether is inhaled or causes eye irritation. Failure to follow this warning may cause death or serious injury to personnel.</p> <p>a. Check for loose connections and damage to lines, fittings, and cylinder. Be alert for odor of leaking ether.</p> <p>b. With ignition on, check that red indicator light on ether electronic control relay is not on.</p>	<p>a. Damage or leakage is evident.</p> <p>b. If red indicator light is on, notify Unit Maintenance.</p>
<p>ETHER FUEL CYLINDER</p>  <p>376-007</p>				

Table 1. Preventive Maintenance Checks and Services (PMCS) for M878A2 - Continued.

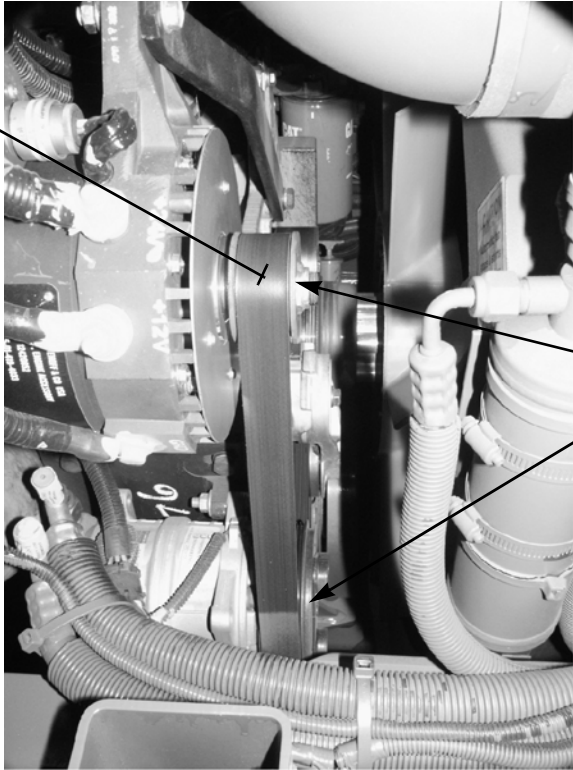

ITEM NO.	INTERVAL	LOCATION ITEM TO CHECK/ SERVICE	PROCEDURE	NOT FULLY MISSION CAPABLE IF:
48	Monthly	Batteries and Capacitor(s)	<div style="display: flex; justify-content: space-around; align-items: center;">   WARNING  </div> <ul style="list-style-type: none"> To avoid injury, eye protection and acid-resistant gloves must be worn when working around batteries. DO NOT smoke, use open flame, make sparks or create other ignition sources around batteries. If a battery is giving off gases, it can explode and cause injury to personnel. Remove all jewelry such as rings, ID tags, watches, and bracelets. If jewelry or a tool contacts a battery terminal, a direct short will result in instant heating or electric shock, injury to personnel, and damage to equipment. To avoid injury, battery box top cover must be removed after it is opened to access batteries. To avoid injury, eye protection, protective clothing, and gloves must be worn when working around capacitors. Capacitors contain an electrolyte that is a potassium hydroxide solution. Potassium hydroxide is highly corrosive and can cause serious burns. If capacitor case becomes cracked, leaking electrolyte can result in fumes that are hazardous to inhale. If electrolyte makes contact with skin, eyes or clothing, take immediate action to stop the corrosive burning effects. Failure to follow these procedures may result in death or serious injury to personnel. Remove all jewelry such as rings, ID tags, watches, and bracelets, when working around capacitors. If jewelry or a tool contacts a capacitor terminal, a direct short may result, causing instant heating and electric shock at the point of short circuit. Damage to equipment and injury to personnel could result. <p style="text-align: center;">CAUTION</p> <p>To reduce battery damage, check battery box for corrosion (greenish/white powder) and do not jerk or pull on battery cables during visual inspection.</p> <p style="text-align: center;">NOTE</p> <p>Vehicles equipped with arctic heater have four batteries and two capacitors.</p> <ol style="list-style-type: none"> a. Release latches and open battery box top cover. Remove top cover from vehicle. Open bottom cover. Check battery box for damaged or missing batteries, capacitor(s), and hold-downs. b. Check for damaged or missing filler caps. c. Check for missing, broken, split or frayed cables. 	

Table 1. Preventive Maintenance Checks and Services (PMCS) for M878A2 - Continued.

ITEM NO.	INTERVAL	LOCATION	ITEM TO CHECK/SERVICE	PROCEDURE	NOT FULLY MISSION CAPABLE IF:
48 (Con't)	Monthly	Batteries and Capacitor(s)		<p>d. Check for damaged terminal posts.</p> <p>e. Check for rust and corrosion.</p> <p>f. Check for cleanliness.</p> <p>g. Report any problems to Unit Maintenance.</p> <p>h. Remove filler caps from batteries and check level of electrolyte. Level should be no more than 1/8 in (3.2 mm) below vent well bottom ring. Notify Unit Maintenance if electrolyte level is low.</p>	

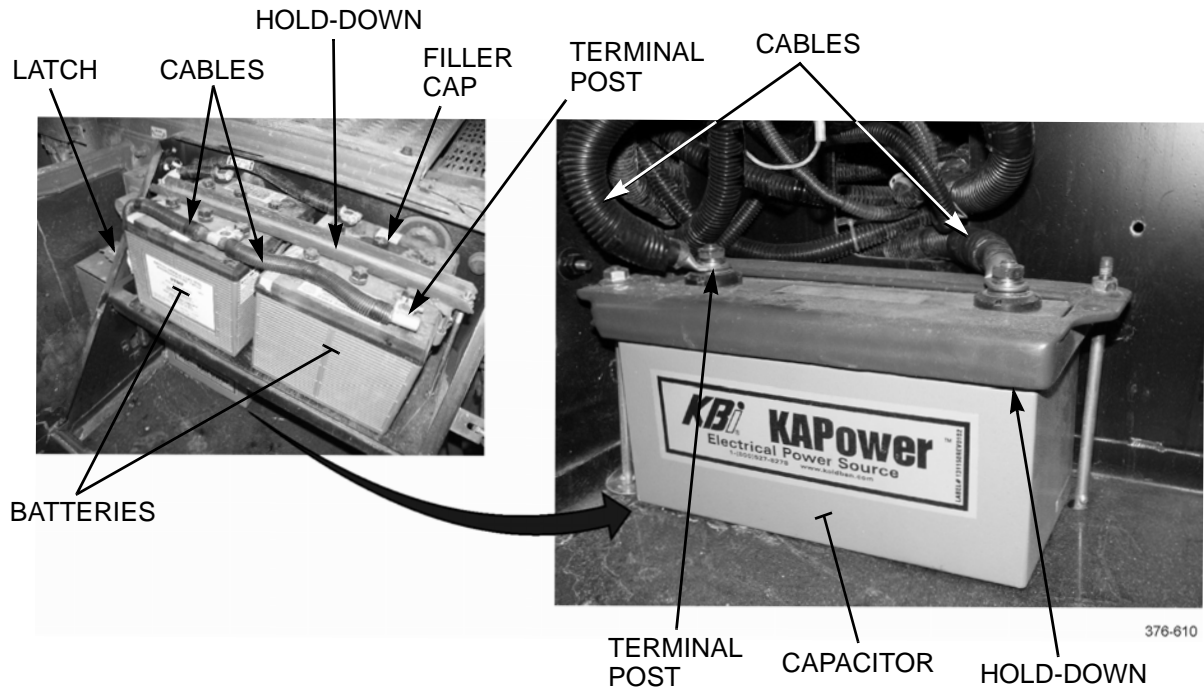

Table 1. Preventive Maintenance Checks and Services (PMCS) for M878A2 - Continued.

ITEM NO.	INTERVAL	LOCATION ITEM TO CHECK/ SERVICE	PROCEDURE	NOT FULLY MISSION CAPABLE IF:
49	Monthly	UNDER VEHICLE Steering Components	a. Check front axle steering components for cracks, breaks, loose connections or other damage. b. Inspect power steering gear, hydraulic hoses, and fittings for evidence of leaks.	a. Any steering component is cracked, broken or loose. b. Class III leaks are evident.
50	Monthly	REAR AND RIGHT SIDE Fifth Wheel Assembly	a. Raise fifth wheel (WP 0005 00). b. Check for damage or leaks to hydraulic hoses, locking valve, and fifth wheel lift cylinders. Be alert for leaks caused by loose head caps and cylinder rod packings. If leakage is noted, notify Unit Maintenance.	b. Damage or Class III leaks are evident.

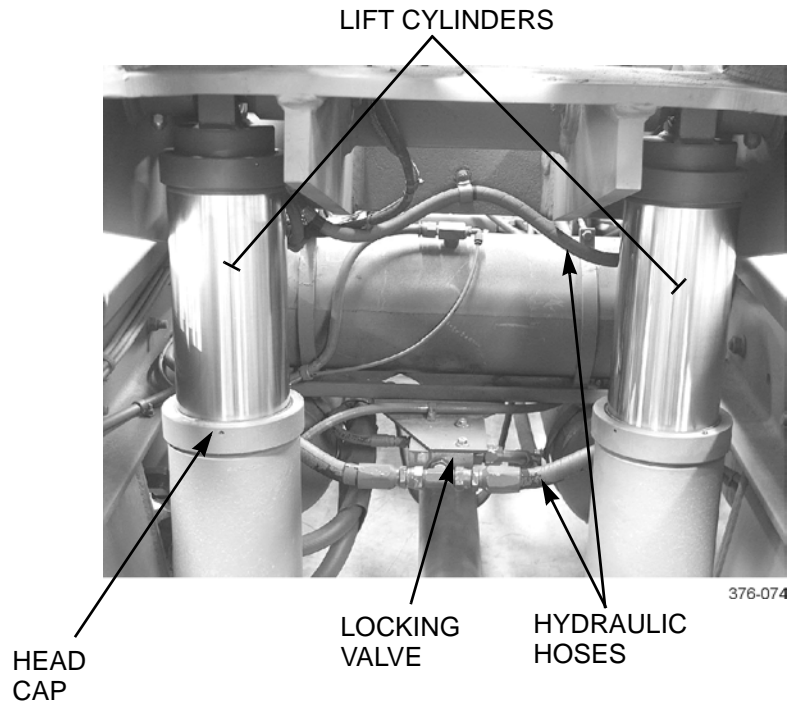

Table 1. Preventive Maintenance Checks and Services (PMCS) for M878A2 - Continued.

ITEM NO.	INTERVAL	LOCATION ITEM TO CHECK/ SERVICE	PROCEDURE	NOT FULLY MISSION CAPABLE IF:
50 (Con't)	Monthly	Fifth Wheel Assembly	c. Apply GAA grease (Item 10, WP 0019 00) to trailer contact surface of fifth wheel plate and to locking jaws and front of throat.	
			<p>d. Lubricate release arm spring and rod and cam pivot and travel path, on underside of fifth wheel plate, with OE/HDO 10 (Item 12, WP 0019 00).</p>	
				
51	Monthly	Pintle Hook	Check pintle hook for loose mounting, damaged locking mechanism, and presence of cotter pin.	

Table 1. Preventive Maintenance Checks and Services (PMCS) for M878A2 - Continued.

ITEM NO.	INTERVAL	LOCATION ITEM TO CHECK/ SERVICE	PROCEDURE	NOT FULLY MISSION CAPABLE IF:
52	Monthly	CAB INTERIOR Doors and Windows	Check operation and general condition of cab doors and windows.	
53	Monthly	OVERALL VEHICLE Undercarriage, Frame, Cab, and Drive Shaft	a. Check for obvious damage to cab (front pivot and rear) mounts, frame, and undercarriage. b. Check drive shaft and U-joints for loose or broken bolts, nuts, and grease fittings.	a. Any loose or broken cab mounts, frame side rails, crossmembers, broken welds or broken bolts are found. b. Mounting bolts and nuts or grease fittings are loose or missing.
54	Monthly	Air System	a. Check all air lines, fittings, and valves for looseness or damage. b. Ensure that dummy coupling vent hole at each front gladhand is not plugged.	a. Any air lines, fittings or valves are loose or damaged.

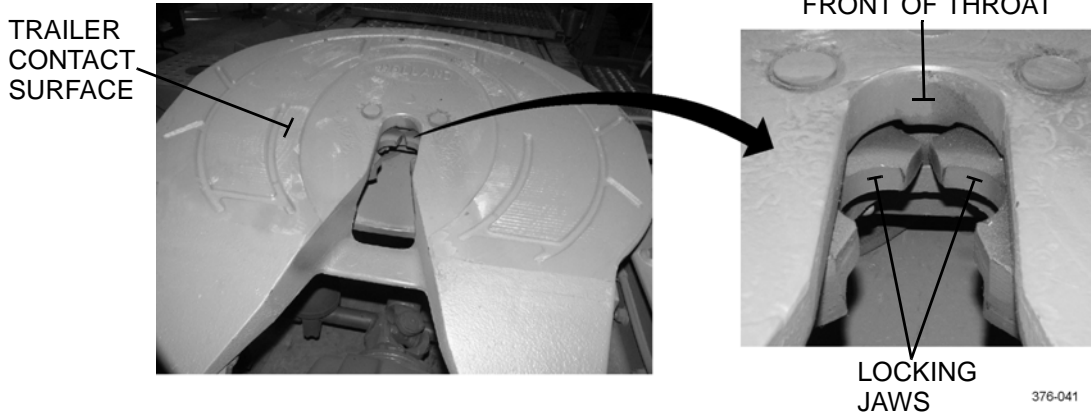
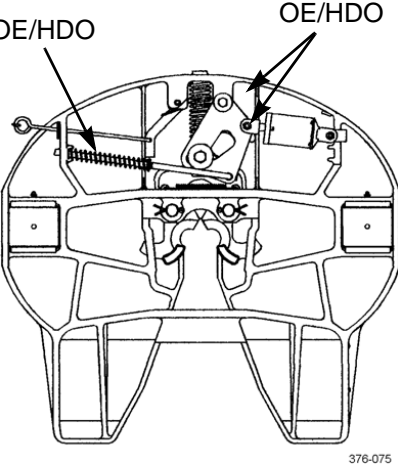
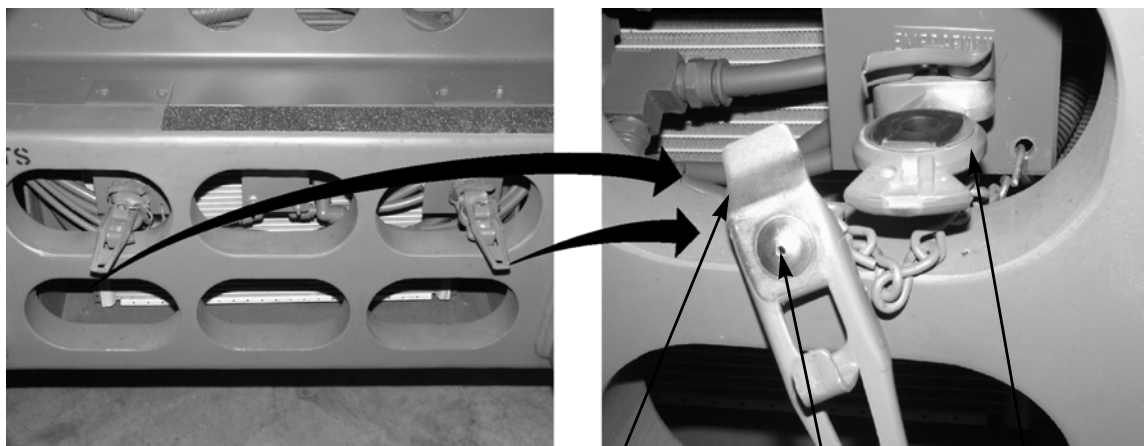

DUMMY COUPLING

VENT HOLE

FRONT GLADHAND

376-072

Table 1. Preventive Maintenance Checks and Services (PMCS) for M878A2 - Continued.

ITEM NO.	INTERVAL	LOCATION ITEM TO CHECK/ SERVICE	PROCEDURE	NOT FULLY MISSION CAPABLE IF:
55	Monthly	Hydraulic Hoses, Fittings, and Cylinders	Check hydraulic hoses, fittings, and cylinders for looseness, damage, and leaks.	Looseness, damage or Class III leaks are evident.
58	Monthly	Air Conditioner	Check air conditioner operation (WP 0005 00). Operate for at least five minutes, to help prevent drying and cracking of tubing seals and reduce refrigerant leaks in the system.	

Table 1. Preventive Maintenance Checks and Services (PMCS) for M878A2 - Continued.

ITEM NO.	INTERVAL	LOCATION ITEM TO CHECK/ SERVICE	PROCEDURE	NOT FULLY MISSION CAPABLE IF:
59	Monthly	Auxiliary Arctic Heater (If Equipped)	Operate arctic heater for at least 15 minutes (WP 0006 00). This will help prevent water pump and combustion engine from seizing.	

END OF WORK PACKAGE

REFUELING AND FUEL SYSTEM PRIMING

0013 00

THIS WORK PACKAGE COVERS

Refueling, Fuel System Priming

INITIAL SETUP

Support Equipment

- Extinguisher, fire (Item 4, Table 2, WP 0017 00)
- Gloves, fuel-resistant

Materials/Parts

- Fuel (Item 9, WP 0019 00)
- Rag, wiping (Item 15, WP 0019 00)

REFUELING



WARNING

- DO NOT smoke or permit any open flame in area of tractor while you are servicing diesel fuel system. Be sure hose nozzle is grounded against filler tube during refueling to prevent static electricity. Failure to follow this warning may result in injury to personnel or equipment damage.
- Wear fuel-resistant gloves when handling fuels and promptly wash exposed skin and change fuel-soaked clothing.
- If equipped with arctic heater, be sure to turn heater off during refueling.

NOTE

- Place portable fire extinguisher within reach prior to refueling.
- DO NOT overfill fuel tank. If fuel starts foaming from fuel tank, stop IMMEDIATELY to avoid fuel spillage.

REFUELING - CONTINUED

1. Shut down engine.
2. Wipe off dirt from on and around filler cap.
3. Turn filler cap counterclockwise to remove cap.
4. Fill tank with fuel to level stenciled on outside of tank.
5. Install filler cap by turning cap clockwise.



376-009

FUEL SYSTEM PRIMING**CAUTION**

DO NOT loosen fuel lines at fuel manifold when priming fuel system. Engine components may be damaged and/or loss of priming pressure may occur when fuel lines are loosened.

NOTE

If engine fails to start because yard tractor ran out of fuel, it may be necessary to prime fuel system.

1. Rotate fuel priming pump plunger counterclockwise to open pump.
2. Pull out and then push in pump plunger by hand until a strong pressure is felt.
3. Turn plunger all the way clockwise after use.

FUEL SYSTEM PRIMING - CONTINUED



376-021

FUEL PRIMING
PUMP PLUNGER
(LEFT SIDE OF TRUCK)

END OF WORK PACKAGE

THIS WORK PACKAGE COVERS

Removal, Installation

INITIAL SETUP

Tools and Special Tools

- Handle/leverage bar (Item 6, Table 2, WP 0017 00)
- Inflator-gage, pneumatic tire (WP 0018 00)
- Jack, hydraulic (Item 9, Table 2, WP 0017 00)

Tools and Special Tools - Continued

- Wrench, socket (Item 10, Table 2, WP 0017 00)

Materials/Parts

- Rag, wiping (Item 15, WP 0019 00)

NOTE

- Notify Unit Maintenance for spare tire and assistance.
- When changing tires, DO NOT substitute type or size tire.

REMOVAL

1. Block wheels.

NOTE

On both sides of vehicle, wheel nuts have right-hand metric threads.

2. Loosen two wheel nuts, and remove remaining eight wheel nuts.



376-073

REMOVAL - CONTINUED

3. Place jack in position:
 - a. For front tire replacement, place jack so that jack ram is under front axle, directly under spring.

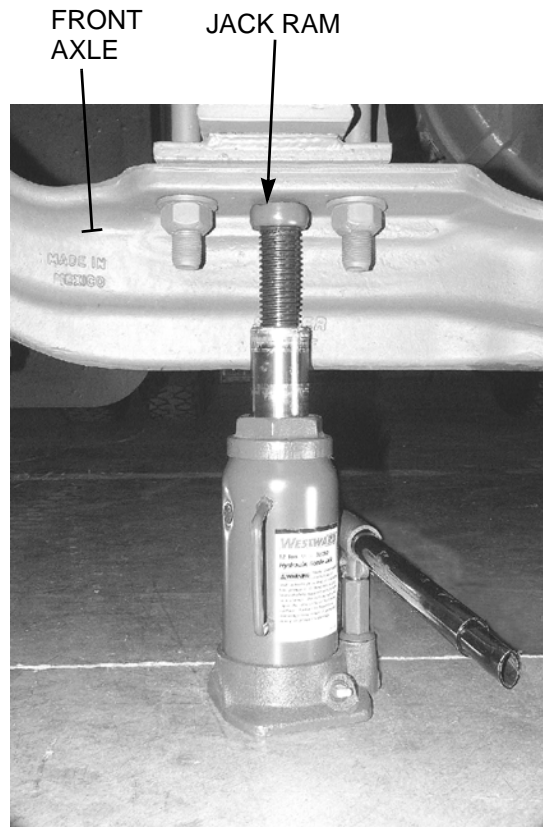

376-03E

REMOVAL - CONTINUED

- b. For rear tire replacement, place jack so that jack ram is under rear axle mounting plate.

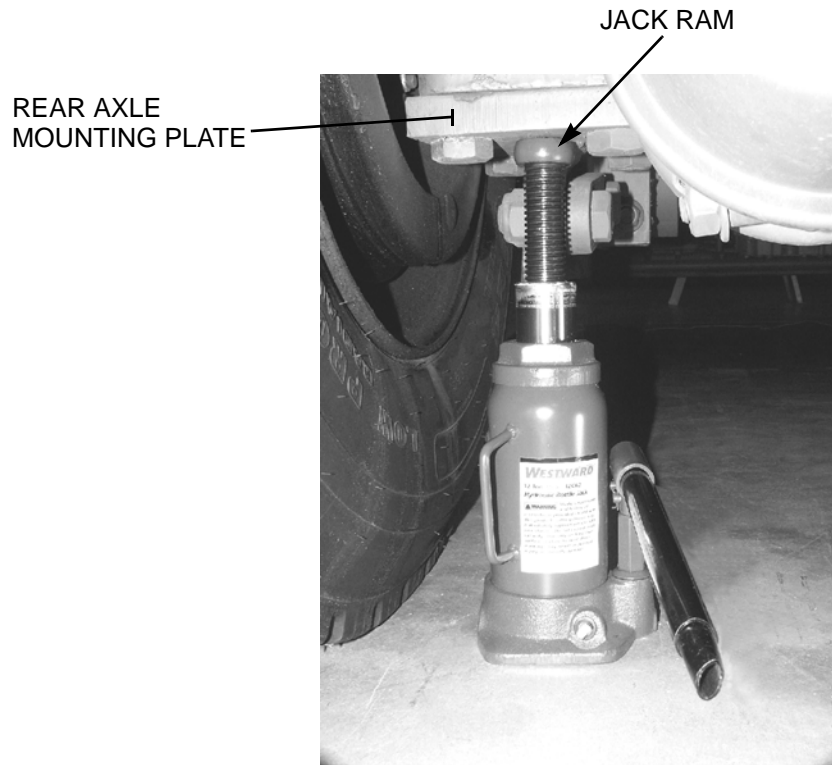

376-032

**WARNING**

Hydraulic jack is intended only for lifting tractor, not for supporting vehicle to perform maintenance. DO NOT get under tractor after it is raised unless it is properly supported with blocks or jackstands. Failure to observe this warning may result in death or injury to personnel.

4. Raise jack until tire(s) clears ground.

REMOVAL - CONTINUED

5. On front axle only, turn wheel until one hub pilot pad is in top-center position.
6. Remove two remaining wheel nuts.

**WARNING**

Use caution when lifting or handling wheel and tire assembly. It is heavy and could cause injury if improperly lifted or if it falls on you.

CAUTION

Wheel center hole and hub pilot have close tolerances. If wheel is not kept square to hub, it could bind during removal and damage stud threads or pilot pads. Keep wheel square to hub during removal.

7. Remove front wheel and tire assembly or outer rear wheel and tire assembly, using care not to allow assembly to drop on or drag across stud threads.
8. As required, remove inner rear wheel and tire assembly, using care not to allow assembly to drop on or drag across stud threads.



376-073

INSTALLATION**NOTE**

Due to speed limitation of vehicle and its load capability, tire manufacturer has authorized a tire inflation of 120 psi (827 kPa).

1. Check tire pressure before installing wheel and tire assembly. Inflate tire to 120 psi (827 kPa) if necessary (WP 0005 00).
2. Clean hub and wheel mounting surfaces on all disc faces of dual wheels of rear axle.

**WARNING**

Use caution when lifting or handling wheel and tire assembly. It is heavy and could cause injury if improperly lifted or if it falls on you.

CAUTION

Wheel center hole and hub pilot have close tolerances. If wheel is not kept square to hub, it could bind during installation and damage stud threads or pilot pads. Keep wheel square to hub during installation.

NOTE

Before installing wheels, ensure that rim is positioned on raised step of pilot pad. One of the hub pilot pads must be at top location.

3. On front axle, place one pilot pad in top-center position. Position front wheel and tire assembly or inner rear wheel and tire assembly on hub using care not to allow assembly to drop on or drag across stud threads.

NOTE

Ensure that valve stems on rear duals are positioned 180° opposite each other.

4. On rear axle, mount outer wheel and tire assembly against inner wheel and tire assembly, using care not to allow assembly to drop on or drag across stud threads.

CAUTION

On both sides of vehicle, wheel nuts have right-hand threads. DO NOT attempt to install a similar size SAE nut on a stud. Failure to follow this caution will result in damage to stud and nut.

5. Install and handtighten two wheel nuts on top and bottom studs.
6. Install and handtighten eight wheel nuts on remaining studs.
7. Lower and remove jack.

INSTALLATION - CONTINUED**WARNING**

Whenever wheel nuts require tightening or a wheel has been removed and replaced, wheel nuts must be tightened to the required torque. Failure to follow this warning may result in serious injury to personnel or damage to equipment.

NOTE

- After 100 miles (161 km), retighten wheel nuts. Tighten again at 500 miles (805 km) and again at 1000 miles (1610 km). Have Unit Maintenance torque wheel nuts to proper torque.
 - Tightening pattern is identical for all wheel and tire assemblies.
8. Tighten wheel nuts according to tightening pattern.

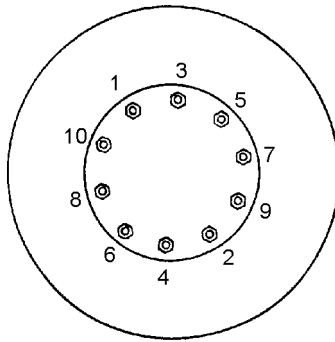

376-035

WHEEL NUT TIGHTENING PATTERN

9. Have Unit Maintenance apply 500 lb-ft (678 Nm) torque.
10. Remove wheel blocks.

END OF WORK PACKAGE

THIS WORK PACKAGE COVERS

Service

INITIAL SETUP

Equipment Condition

Engine shut down

Materials/Parts

Rag, wiping (Item 15, WP 0019 00)



WARNING



- If NBC exposure is suspected, personnel wearing protective equipment must handle all air cleaner media. Consult your NBC Officer or NBC NCO for appropriate handling or disposal procedures.
- NBC contaminated filters must be handled using adequate precautions (FM 21-40) and must be disposed of by trained personnel.

CAUTION

Service engine air cleaner with engine shut down. Engine damage could result if service is performed with engine running.

SERVICE

1. Release three clamps and remove cover from air cleaner housing.

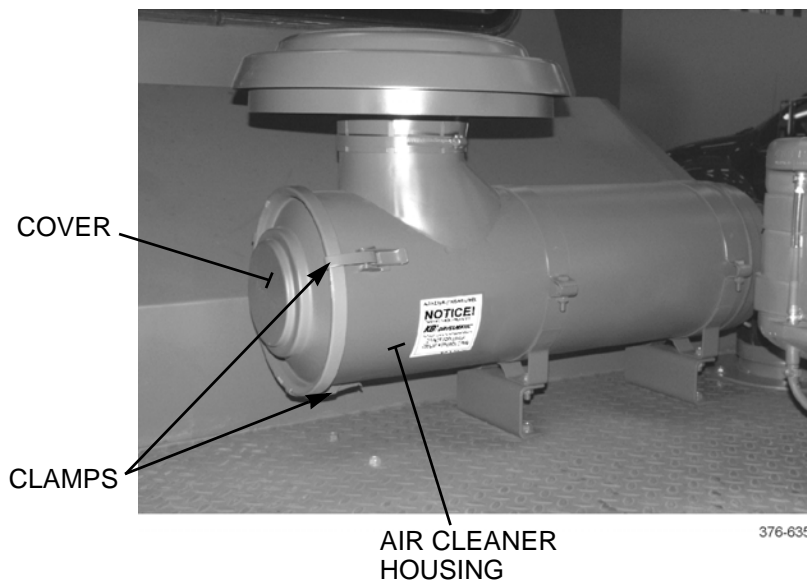

SERVICE - CONTINUED

2. Remove filter element from housing.
3. Wipe inside of housing with a clean rag.

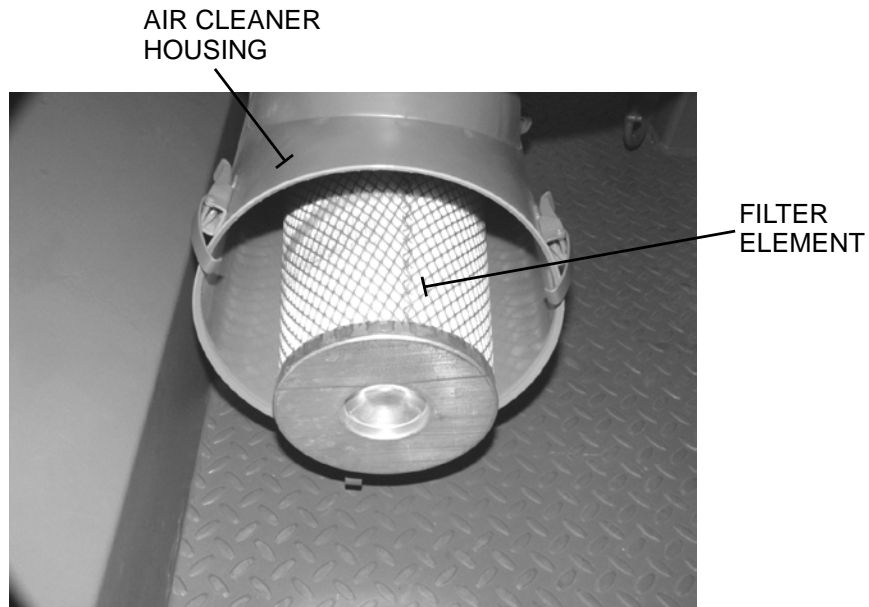

4. Lightly tap filter element to remove loose dirt and dust.
5. Inspect filter element for damaged pleats, wire mesh housing or seal. Notify Unit Maintenance to obtain replacement filter element if damage is found.

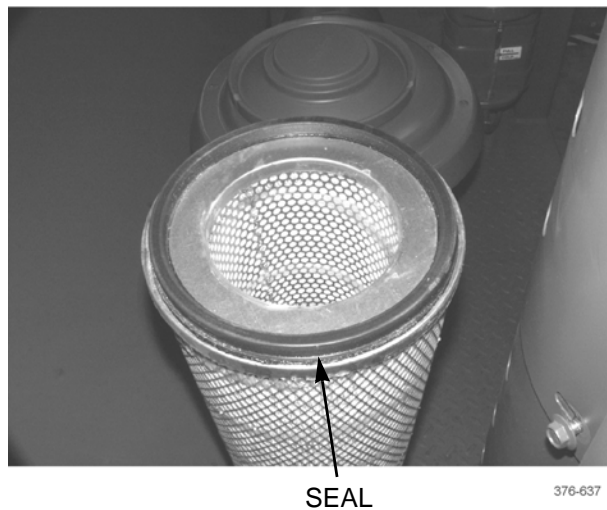

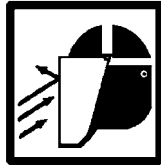
SERVICE - CONTINUED**WARNING**

Compressed air used for cleaning purposes should never exceed 30 psi (207 kPa). Wear protective clothing (goggles/shield, gloves, etc.) and use caution to avoid injury to personnel.

6. Use compressed air, directed along pleats from the inside out, to remove dirt and dust from filter element.
7. Inspect filter element after cleaning. Notify Unit Maintenance to obtain replacement filter element if damage is found.
8. Install filter element inside housing, with smaller closed end facing outward.
9. Install cover on housing and secure with three clamps

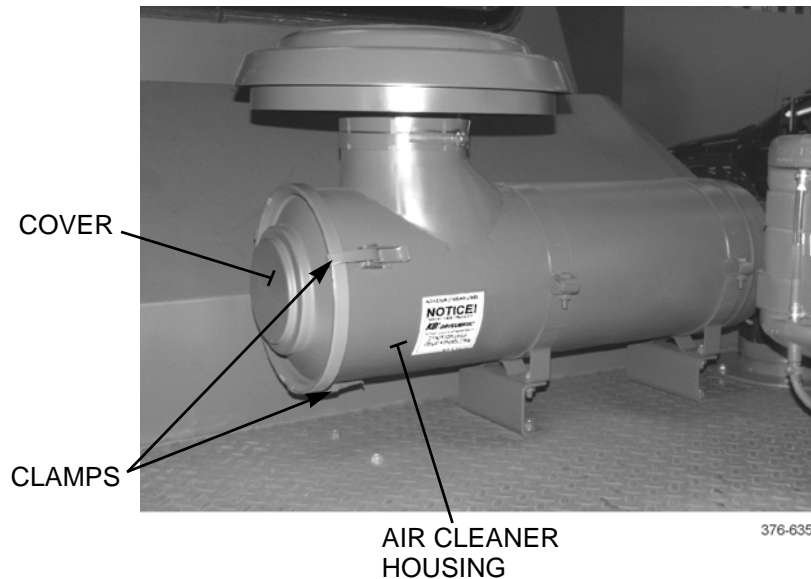

10. Reset air cleaner restriction indicator on instrument panel (WP 0004 00) by pressing yellow reset button at bottom of gauge.
11. Start engine (WP 0005 00).
12. Ensure yellow band on air cleaner restriction indicator is in green zone on gauge. If gauge shows yellow band in red zone, notify Unit Maintenance

END OF WORK PACKAGE

CHAPTER 5
SUPPORTING INFORMATION

REFERENCES

0016 00

SCOPE

This work package lists all forms, field manuals, technical manuals, and other publications referenced in this manual and which apply to the operation of the M878A2 Yard Tractor.

PUBLICATION INDEXES

The following indexes should be consulted frequently for latest changes or revisions and for new publications relating to material covered in this technical manual.

- Consolidated Army Publications and Forms Index DA Pam 25-30
- Consolidated Publication of Component Lists EM 0074
- Functional Users Manual for The Army Maintenance Management System (TAMMS) DA Pam 738-750

FORMS

Refer to DA Pam 738-750, *Functional Users Manual for The Army Maintenance Management System (TAMMS)*, for instructions on the use of maintenance forms.

- Equipment Inspection and Maintenance Worksheet DA Form 2404
- Equipment Log Assembly (Records) DA Form 2408
- Product Quality Deficiency Report SF Form 368
- Recommended Changes to Publications and Blank Forms DA Form 2028

FIELD MANUALS

- Basic Cold Weather Manual FM 31-70
- Cargo Specialists' Handbook FM 55-17
- Chemical and Biological Contamination Avoidance FM 3-3
- Defense Against Chemical Attack FM 21-40
- Desert Operations FM 90-3
- First Aid FM 4-25.11
- Manual for the Wheeled Vehicle Driver FM 21-305
- NBC Decontamination FM 3-5
- NBC Protection FM 3-4
- Northern Operations FM 31-71
- Nuclear Contamination Avoidance FM 3-3-1
- Operations and Maintenance of Ordnance Materiel in Cold Weather FM 9-207

TECHNICAL MANUALS

- Care, Maintenance, Repair, and Inspection of Pneumatic Tires and Inner Tubes TM 9-2610-200-14
- Destruction of Army Materiel to Prevent Enemy Use TM 750-244-6
- Operator's, Unit, Intermediate Direct Support, and Intermediate General Support
Maintenance Manual for Lead-Acid Storage Batteries TM 9-6140-200-14

TECHNICAL BULLETINS

- Warranty Bulletin for M878A2 TB 9-2320-312-14

REFERENCES - CONTINUED

0016 00

OTHER PUBLICATIONS

Abbreviations and Acronyms ASME Y14.38-1999
Army Medical Department Expendable/Durable Items CTA 8-100
Expendable/Durable Items (Except Medical, Class V, Repair Parts, and Heraldic Items) CTA 50-970
Prevention of Motor Vehicle Accidents AR 385-55
Transportability Criteria MIL-STD-1366D

END OF WORK PACKAGE

SCOPE

This work package lists COEI and BII for the M878A2 Yard Tractor, to help you inventory items required for safe and efficient operation.

GENERAL

The COEI and BII information is divided into the following lists:

1. **Table 1, Components of End Item List.** This listing is for informational purposes only and is not authority to requisition replacements. These items are part of the end item, but are removed and separately packaged for transportation or shipment. As part of the end item, these items must be with the end item whenever it is issued or transferred between property accounts. Illustrations are furnished to assist you in identifying the items.
2. **Table 2, Basic Issue Items List.** These are the minimum essential items required to place the tractor in operation, to operate it, and to perform emergency repairs. Although shipped separately packaged, BII must be with the tractor during operation and whenever it is transferred between property accounts. This manual is your authority to request/requisition replacement BII, based on TOE/MTOE authorization of end item. Illustrations are furnished to assist you in identifying the items.

EXPLANATION OF COLUMNS

Below is an explanation of columns found in the tabular listings:

1. **Column (1) - Illustration Number (Illus Number).** This column indicates the number of the illustration that shows the item.
2. **Column (2) - National Stock Number.** Indicates the National Stock Number (NSN) assigned to the item and will be used for requisitioning purposes.
3. **Column (3) - Description, CAGEC, and Part Number.** Indicates the Federal item name (in all capital letters) and, if required, a minimum description in parentheses to identify and locate the item. The entry for each item ends with the Commercial and Government Entity Code (CAGEC) in parentheses followed by the part number.
4. **Column (4) - Usable on Code.** Indicates a code if the item needed is not the same for different models of equipment. Usable on Code is not applicable to the M878A2.
5. **Column (5) - Unit of Measure (U/M).** Indicates how the item is issued for the National Stock Number shown in Column (2).
6. **Column (6) - Quantity Required (Qty Rqd).** Indicates the quantity of the item required.

Table 1. Components of End Item List.

*THERE ARE CURRENTLY NO COEI ASSIGNED
TO THE M878A2 YARD TRACTOR.*

Table 2. Basic Issue Items List.

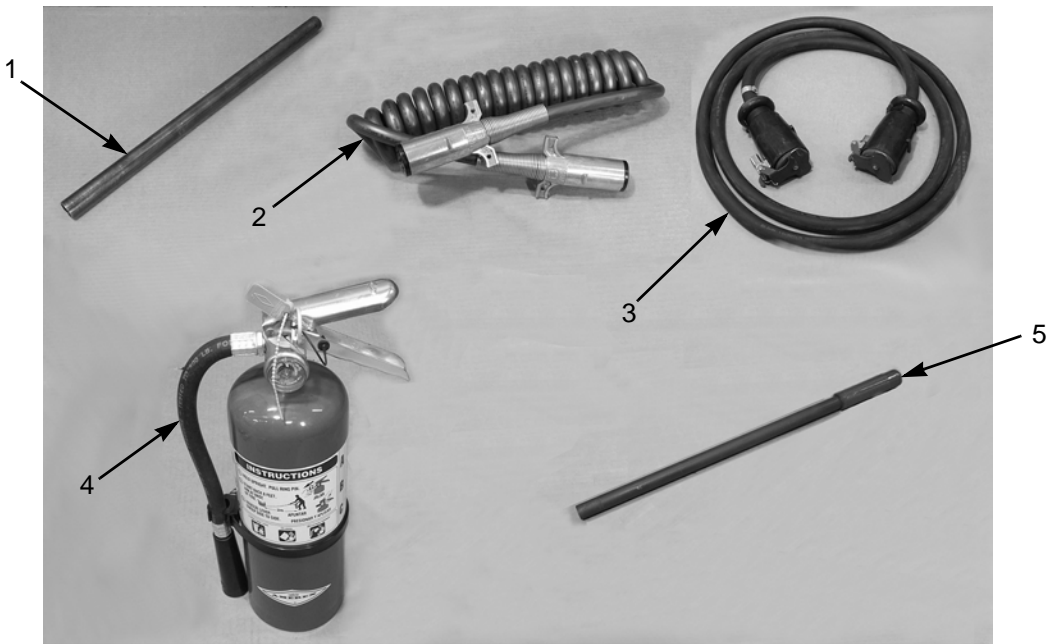

376-051

(1) ILLUS NUMBER	(2) NATIONAL STOCK NUMBER	(3) DESCRIPTION, CAGEC, AND PART NUMBER	(4) USABLE ON CODE	(5) U/M	(6) QTY RQD
1	5120-01-526-9895	EXTENSION, SOCKET WRENCH (03533) 319C-655		EA	1
2	6150-01-509-6384	CABLE ASSEMBLY, SPECIAL PURPOSE, ELECTRICAL: 12V (03533) 73-226		EA	1
3	6150-00-772-8814	CABLE ASSEMBLY, SPECIAL PURPOSE, ELECTRICAL: 24V (19207) 7728814		EA	1
4	4210-01-493-8159	EXTINGUISHER, FIRE (54905) B500		EA	1
5	5340-01-526-9896	HANDLE, MANUAL CONTROL: Cab Tilt Pump (03533) 142-250		EA	1

Table 2. Basic Issue Items List - Continued.

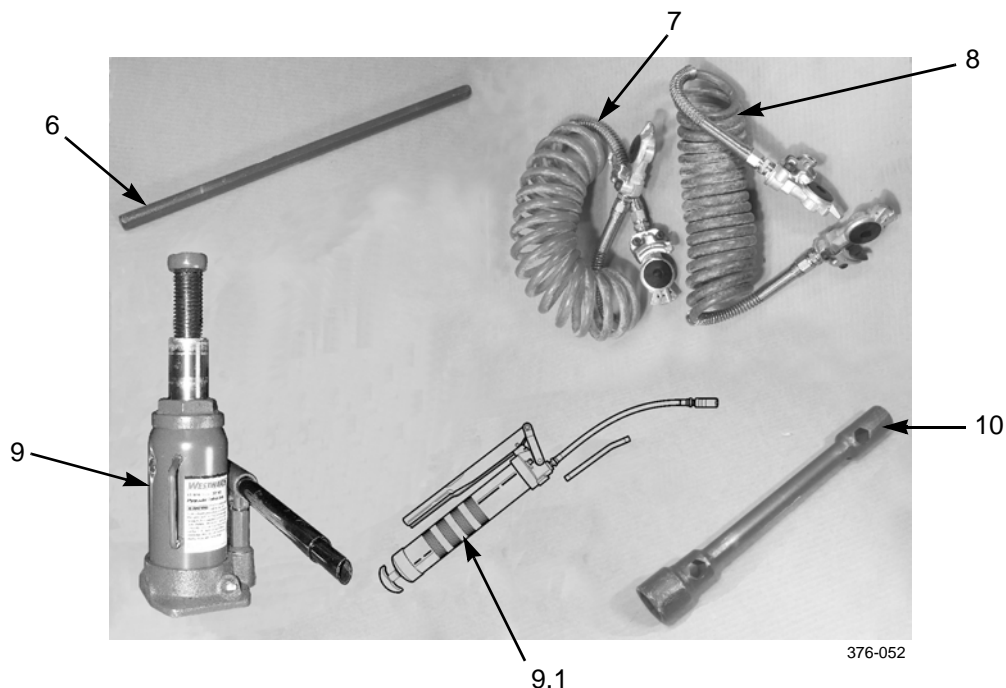

(1) ILLUS NUMBER	(2) NATIONAL STOCK NUMBER	(3) DESCRIPTION, CAGEC, AND PART NUMBER	(4) USABLE ON CODE	(5) U/M	(6) QTY RQD
6	5120-01-526-5106	BAR, SOCKET WRENCH HANDLE: (0VW60) E-5854		EA	1
7	4720-01-526-5146	HOSE, NONMETALLIC: Intervehicular, Emergency (Red) (0N972) 451035-R		EA	1
8	4720-01-526-5108	HOSE, NONMETALLIC: Intervehicular, Service (Blue) (03533) 451035-B		EA	1
9	5120-01-510-7486	JACK, HYDRAULIC, HAND: 12-Ton Capacity (03533) A171-2		EA	1
9.1	4930-00-253-2478	LUBRICATING GUN, Hand (1PL57) 1142		EA	1
10	5120-01-526-5102	WRENCH, SOCKET: Metric, 22mm X 33mm (0VW60) E-6038		EA	1

END OF WORK PACKAGE

ADDITIONAL AUTHORIZATION LIST (AAL)

0018 00**SCOPE**

This work package lists additional items that you are authorized for support of the M878A2 Yard Tractor.

GENERAL

This list identifies items that do not have to accompany the tractor and that do not have to be turned in with it. These items are authorized to you by CTA, MTOE TDA or JTA.

EXPLANATION OF COLUMNS

1. **Column (1) - National Stock Number.** Indicates the National Stock Number (NSN) assigned to the item and will be used for requisitioning purposes.
2. **Column (2) - Description, CAGEC, and Part Number.** Indicates the Federal item name (in all capital letters) followed by a minimum description when needed. The entry for each item ends with the Commercial and Government Entity Code (CAGEC) in parentheses followed by the part number.
3. **Column (3) - Usable on Code.** Indicates a code if the item needed is not the same for different models of equipment. Usable on Code is not applicable for the M878A2.
4. **Column (4) - Unit of Measure (U/M).** Indicates how the item is issued for the National Stock Number shown in Column (1).
5. **Column (5) - Qty Recm.** Indicates the quantity recommended.

Table 1. Additional Authorization List.

(1) NATIONAL STOCK NUMBER	(2) DESCRIPTION, CAGEC, AND PART NUMBER	(3) USABLE ON CODE	(4) U/M	(5) QTY RECM
2920-01-503-5540	COLD START, KIT (03533) 2000-4170		EA	1
2990-01-498-9108	HEATER, COOLANT, ENGINE (03533) 156B-58		EA	1
4910-01-417-2734	INFLATOR-GAGE, PNEUMATIC TIRE (19207) 11677140-10		EA	1
5340-00-158-3805	PADLOCK (58536) AA59487-2S		EA	4
2610-01-507-3633	TIRE, PNEUMATIC, VEHICULAR (04NP3) 138-803-230		EA	1
2530-01-496-4034	WHEEL SEGMENT, PNEUMATIC (4Y282) 2212-B69-10		EA	1

END OF WORK PACKAGE

SCOPE

This work package lists expendable and durable items you will need to operate and maintain the M878A2 Yard Tractor. This listing is for informational purposes only and is not authority to requisition the listed items. These items are authorized to you by CTA 50-970, *Expendable/Durable Items (Except Medical, Class V, Repair Parts, and Heraldic Items)*, or CTA 8-100, *Army Medical Department Expendable/Durable Items*.

EXPLANATION OF COLUMNS

1. **Column (1) - Item Number.** This number is assigned to the entry in the listing and is referenced in the narrative instructions to identify the item [e.g., Use antifreeze (Item 1, WP 0019 00)].
2. **Column (2) - Level.** This column identifies the lowest level of maintenance that requires the listed item.
C - Operator/Crew
3. **Column (3) - National Stock Number.** This is the National Stock Number assigned to the item which you can use to requisition it.
4. **Column (4) - Description, CAGEC, and Part Number.** This provides the other information you need to identify the item.
5. **Column (5) - Unit of Measure (U/M).** This column shows the physical measurement or count of an item, such as gallon, dozen, gross, etc.

Table 1. Expendable and Durable Items List.

(1) ITEM NUMBER	(2) LEVEL	(3) NATIONAL STOCK NUMBER	(4) DESCRIPTION, CAGEC, AND PART NUMBER	(5) U/M
1	C	6850-01-441-3218	ANTIFREEZE: Permanent Ethylene Glycol, Inhibited, Heavy-Duty (58536) A-A-52624-1-A 1 Gallon Can	GAL
		6850-00-181-7933	(81349) MILA46153 5 Gallon Container	GAL
		6850-01-441-3223	(58536) A-A-52624-1-A 55 Gallon Drum	GAL
(Deleted)				
3	C	6850-01-474-2320	CLEANING COMPOUND: Solvent, Type III (81349) MIL-PRF-680 5 Gallon Can	GAL
		6850-01-474-2321	55 Gallon Drum	GAL
4	C	6850-00-926-2275	CLEANING COMPOUND: Windshield (0FTT5) 0854000 16 Ounce Bottle	OZ
5	C	7930-00-282-9699	DETERGENT: General Purpose, Liquid (83421) 7930-00-282-9699 1 Gallon Can	GAL
6	C	9150-00-698-2382	FLUID: Hydraulic, Automatic Transmission (24617) Dexron III 1 Quart Can	QT
		9150-01-114-9968	55 Gallon Drum	GAL
7	C	9150-00-223-4134	FLUID: Hydraulic, Petroleum Base (81349) MIL-H-5606 1 Gallon Can	GAL
		9150-00-082-7524	10 Gallon Drum	GAL
8	C	9150-00-985-7231	FLUID: Hydraulic, Petroleum Base (81349) MIL-PRF-17672, Grade 32 1 Quart Can	QT
		9150-00-985-7232	5 Gallon Can	GAL
		9150-00-985-7233	55 Gallon Drum	GAL
9	C	9130-01-031-5816	FUEL, TURBINE: Aviation (81349) MILT83133 GR JP8	GAL

Table 1. Expendable and Durable Items List - Continued.

(1) ITEM NUMBER	(2) LEVEL	(3) NATIONAL STOCK NUMBER	(4) DESCRIPTION, CAGEC, AND PART NUMBER	(5) U/M
10	C	9150-01-197-7688	GREASE: Automotive and Artillery GAA (81349) M-10924-A 1-1/4 Ounce Tube	OZ
		9150-01-197-7693	(81349) M-10924-B 14 Ounce Cartridge	OZ
		9150-01-197-7690	(81349) M-10924-C 1-3/4 Pound Can	LB
		9150-01-197-7692	(81349) M-10924-E 35 Pound Can	LB
11	C	9150-00-402-4478	OIL: Lubricating, Arctic, OEA (81349) MIL-L-46167 1 Quart Can	QT
		9150-00-402-2372	(81349) MIL-PRF-46167 5 Gallon Drum	GAL
		9150-00-491-7197	(81349) MIL-PRF-46167 55 Gallon Drum	GAL
12	C	9150-00-189-6727	OIL: Lubricating, OE/HDO 10 (81349) MIL-PRF-2104	QT
		9150-00-186-6668	5 Gallon Can	GAL
		9150-00-191-2772	55 Gallon Drum	GAL
13	C	9150-00-247-0481	OIL: Lubricating, OE/HDO 10W/30 (81349) MIL-L-2104	QT
14	C	9150-01-152-4117	OIL: Lubricating, OE/HDO 15W/40 (81349) MIL-PRF-2104	QT
		9150-01-152-4118	5 Gallon Can	GAL
		9150-01-152-4119	55 Gallon Drum	GAL
15	C	7920-00-205-1711	RAG: Wiping (64067) 7920-00-205-1711 50 Pound Bale	LB

END OF WORK PACKAGE

INDEX

<u>Subject</u>	<u>WP Sequence No. - Page No.</u>
A	
Abbreviations, List of	0001 00-2
Additional Authorization List (AAL)	0018 00-1
Additional Controls and Indicators	0004 00-16
Air Cleaner, Engine, Service	0015 00-1
Air Conditioner, Operate	0005 00-10
Air Conditioning System, Theory of Operation	0003 00-5
Air System, Theory of Operation	0003 00-2
Auxiliary Arctic Heater System (If Equipped), Theory of Operation	0003 00-8
B	
Brake System, Theory of Operation	0003 00-2
Brakes, Cage and Uncage	0006 00-4
C	
Cab Floor-Mounted Controls	0004 00-9
Cab Tilt System Controls	0004 00-12
Cab Tilt System, Operate	0005 00-13
Cab Tilt System, Theory of Operation	0003 00-5
Cage Brakes	0006 00-4
Components of End Item (COEI) and Basic Issue Items (BII) Lists	0017 00-1
Cooling System, Theory of Operation	0003 00-2
Corrosion Prevention and Control (CPC)	0001 00-1
Couple to Trailer	0005 00-8
D	
Data Plates	0007 00-16
Decals	0007 00-2
Defroster, Operate	0005 00-11
Description and Data, Equipment	0002 00-1
Destruction of Army Materiel to Prevent Enemy Use	0001 00-1
Drive Train, Theory of Operation	0003 00-1
Driving	0005 00-6
Driving Tips	0005 00-4

INDEX - Continued

<u>Subject</u>	<u>WP Sequence No. - Page No.</u>
E	
Electrical System, Theory of Operation	0003 00-2
Engine	
Air Cleaner Service	0015 00-1
Shut Down	0005 00-6
Start	0005 00-2
Equipment Description and Data	0002 00-1
Equipment Improvement Recommendation (EIRs), Reporting	0001 00-1
Exhaust System, Theory of Operation	0003 00-2
Expendable and Durable items List	0019 00-1
F	
Fifth Wheel Controls	0004 00-14
Fifth Wheel Lift, Operate	0005 00-6
Fifth Wheel System, Theory of Operation	0003 00-3
Fire Extinguisher, Portable, Operate	0005 00-12
Fuel System	
Priming	0013 00-1
Theory of Operation	0003 00-1
H	
Heater, Operate	0005 00-10
I	
Inflate Tire	0005 00-20
Initial Adjustments, Daily Checks, and Self-Tests	0005 00-1
Instrument and Warning Light Cluster	0004 00-6
Instrument Panel	0004 00-1
Introduction, Theory of Operation	0003 00-1
L	
List	
Abbreviations	0001 00-2
Additional Authorization List (AAL)	0018 00-1
Basic Issue Items (BII)	0017 00-1
Components of End Item (COEI)	0017 00-1
Expendable and Durable Items	0019 00-1
Nomenclature Cross-Reference	0001 00-2
Location and Description of Major Components	0002 00-2

INDEX - Continued**Subject****WP Sequence No. - Page No.****L - Continued**

Lubrication Procedures, General 0011 00-3

M

Maintenance Forms, Records, and Reports 0001 00-1

Major Components, Location and Description of 0002 00-2

N

Nomenclature Cross-Reference List 0001 00-2

O**Operate**

Air Conditioner 0005 00-10

Cab Tilt System 0005 00-13

Defroster 0005 00-11

Fifth Wheel Lift 0005 00-6

Heater 0005 00-10

In Extreme Cold 0006 00-6

In Extreme Heat 0006 00-9

In Mud or Soft Surfaces 0006 00-10

In Sandy or Dusty Conditions 0006 00-10

On Snow or Ice 0006 00-11

Portable Fire Extinguisher 0005 00-12

Transmission 0005 00-3

Ventilator 0005 00-11

Operator's Controls and Indicators

Additional Controls and Indicators 0004 00-16

Cab Floor-Mounted Controls 0004 00-9

Cab Tilt System Controls 0004 00-12

Fifth Wheel Controls 0004 00-14

Instrument and Warning Light Cluster 0004 00-6

Instrument Panel 0004 00-1

Seat and Seat Belt Controls 0004 00-10

Steering Wheel and Column-Mounted Controls 0004 00-8

Transmission Range Selector Lever 0004 00-15

P

Preparation for Storage or Shipment 0001 00-1

Preventive Maintenance Checks and Services (PMCS) for M878A2 0012 00-1

Preventive Maintenance Checks and Services (PMCS) Introduction 0011 00-1

Priming Fuel System 0013 00-1

INDEX - Continued

<u>Subject</u>	<u>WP Sequence No. - Page No.</u>
R	
References	0016 00-1
Refueling	0013 00-1
Reporting Equipment Improvement Recommendations (EIRs)	0001 00-1
Roll-On/Roll-Off (RO/RO) Procedures	0005 00-21
S	
Seat and Seat Belt Controls	0004 00-10
Shipment, Preparation for	0001 00-1
Shut Down Engine	0005 00-6
Slave Start Tractor	0006 00-1
Start Engine	0005 00-2
Steering System, Theory of Operation	0003 00-3
Steering Wheel and Column-Mounted Controls	0004 00-8
Stencils	0007 00-19
Storage, Preparation for	0001 00-1
Stowage Guide	0007 00-1
T	
Theory of Operation	
Air Conditioning System	0003 00-5
Air System	0003 00-2
Auxiliary Arctic Heater System (If Equipped)	0003 00-8
Brake System	0003 00-2
Cab Tilt System	0003 00-5
Cooling System	0003 00-2
Drive Train	0003 00-1
Electrical System	0003 00-2
Exhaust System	0003 00-2
Fifth Wheel System	0003 00-3
Fuel System	0003 00-1
Introduction	0003 00-1
Steering System	0003 00-3
Tire, Inflate	0005 00-20
Towing Tractor	0006 00-3
Transmission Range Selector Lever, Operator's Controls and Indicators	0004 00-15
Transmission, Operate	0005 00-3

INDEX - Continued

Subject

WP Sequence No. - Page No.

T - Continued

Troubleshooting	
Instructions	0008 00-1
Procedures	0010 00-1
Symptom Index	0009 00-1

U

Uncage Brakes	0006 00-4
Uncouple from Trailer	0005 00-10

V

Ventilator, Operate	0005 00-11
---------------------------	------------

W

Warranty Information	0001 00-1
----------------------------	-----------

By Order of the Secretary of the Army:

PETER J. SCHOOMAKER
General, United States Army
Chief of Staff

Official:

JOEL B. HUDSON
Administrative Assistant to the
Secretary of the Army
0304104

DISTRIBUTION: To be distributed in accordance with the initial distribution requirements for IDN: 381128, requirements for TM 9-2320-312-10.

RECOMMENDED CHANGES TO PUBLICATIONS AND BLANK FORMS						Use Part II (reverse) for Repair Parts and Special Tool Lists (RPSTL) and Supply Catalogs/Supply Manuals (SC/SM).	DATE
For use of this form, see AR 25-30: the proponent agency is ODISC4.							
TO: (Forward to proponent of publication or form) (Include ZIP Code) AMSTALC-LMIT / TECH PUBS, TACOM-RI 1 Rock Island Arsenal Rock Island, IL 61299-7630						FROM: (Activity and location) (Include ZIP Code)	
PART I - ALL PUBLICATIONS (EXCEPT RPSTL AND SC/SM) AND BLANK FORMS							
PUBLICATION/FORM NUMBER TM 9-2320-312-10					DATE 17 December 2003	TITLE M878A2 Truck, Tractor, Yard Type	
ITEM NO.	PAGE NO.	PARA-GRAPH	LINE NO. *	FIGURE NO.	TABLE NO.	RECOMMENDED CHANGES AND REASON (Provide exact wording of recommended changes, if possible).	
<i>*Reference to line numbers within the paragraph or subparagraph.</i>							
TYPED NAME, GRADE OR TITLE				TELEPHONE EXCHANGE/AUTOVON, PLUS EXTENSION		SIGNATURE	

TO: <i>(Forward direct to addressee listed in publication)</i> AMSTALC-LMIT / TECH PUBS, TACOM-RI 1 Rock Island Arsenal Rock Island, IL 61299-7630	FROM: <i>(Activity and location) (Include ZIP Code)</i>	DATE
--	--	-------------

PART II – REPAIR PARTS AND SPECIAL TOOL LISTS AND SUPPLY CATALOGS/SUPPLY MANUALS

PUBLICATION NUMBER TM 9-2320-312-10	DATE 17 December 2003	TITLE M878A2 Truck, Tractor, Yard Type
--	--------------------------	---

PAGE NO.	COLM NO.	LINE NO.	NATIONAL STOCK NUMBER	REFERENCE NO.	FIGURE NO.	ITEM NO.	TOTAL NO. OF MAJOR ITEMS SUPPORTED	RECOMMENDED ACTION

PART III – REMARKS *(Any general remarks or recommendations, or suggestions for improvement of publications and blank forms. Additional blank sheets may be used if more space is needed.)*

TYPED NAME, GRADE OR TITLE	TELEPHONE EXCHANGE/AUTOVON, PLUS EXTENSION	SIGNATURE
----------------------------	--	-----------

RECOMMENDED CHANGES TO PUBLICATIONS AND BLANK FORMS						Use Part II (reverse) for Repair Parts and Special Tool Lists (RPSTL) and Supply Catalogs/Supply Manuals (SC/SM).	DATE
For use of this form, see AR 25-30; the proponent agency is ODISC4.							
TO: (Forward to proponent of publication or form) (Include ZIP Code) AMSTALC-LMIT / TECH PUBS, TACOM-RI 1 Rock Island Arsenal Rock Island, IL 61299-7630						FROM: (Activity and location) (Include ZIP Code)	
PART I - ALL PUBLICATIONS (EXCEPT RPSTL AND SC/SM) AND BLANK FORMS							
PUBLICATION/FORM NUMBER TM 9-2320-312-10						DATE 17 December 2003	TITLE M878A2 Truck, Tractor, Yard Type
ITEM NO.	PAGE NO.	PARA-GRAPH	LINE NO. *	FIGURE NO.	TABLE NO.	RECOMMENDED CHANGES AND REASON (Provide exact wording of recommended changes, if possible).	
<i>*Reference to line numbers within the paragraph or subparagraph.</i>							
TYPED NAME, GRADE OR TITLE				TELEPHONE EXCHANGE/AUTOVON, PLUS EXTENSION		SIGNATURE	

TO: <i>(Forward direct to addressee listed in publication)</i> AMSTALC-LMIT / TECH PUBS, TACOM-RI 1 Rock Island Arsenal Rock Island, IL 61299-7630	FROM: <i>(Activity and location) (Include ZIP Code)</i>	DATE
--	--	-------------

PART II – REPAIR PARTS AND SPECIAL TOOL LISTS AND SUPPLY CATALOGS/SUPPLY MANUALS

PUBLICATION NUMBER TM 9-2320-312-10	DATE 17 December 2003	TITLE M878A2 Truck, Tractor, Yard Type
---	---------------------------------	--

PAGE NO.	COLM NO.	LINE NO.	NATIONAL STOCK NUMBER	REFERENCE NO.	FIGURE NO.	ITEM NO.	TOTAL NO. OF MAJOR ITEMS SUPPORTED	RECOMMENDED ACTION

PART III – REMARKS *(Any general remarks or recommendations, or suggestions for improvement of publications and blank forms. Additional blank sheets may be used if more space is needed.)*

TYPED NAME, GRADE OR TITLE	TELEPHONE EXCHANGE/AUTOVON, PLUS EXTENSION	SIGNATURE
----------------------------	--	-----------

RECOMMENDED CHANGES TO PUBLICATIONS AND BLANK FORMS For use of this form, see AR 25-30: the proponent agency is ODISC4.	Use Part II (reverse) for Repair Parts and Special Tool Lists (RPSTL) and Supply Catalogs/Supply Manuals (SC/SM).	DATE
---	---	------

TO: (Forward to proponent of publication or form) (Include ZIP Code) AMSTALC-LMIT / TECH PUBS, TACOM-RI 1 Rock Island Arsenal Rock Island, IL 61299-7630	FROM: (Activity and location) (Include ZIP Code)
--	---

PART I - ALL PUBLICATIONS (EXCEPT RPSTL AND SC/SM) AND BLANK FORMS

PUBLICATION/FORM NUMBER TM 9-2320-312-10	DATE 17 December 2003	TITLE M878A2 Truck, Tractor, Yard Type
---	--------------------------	---

ITEM NO.	PAGE NO.	PARA-GRAPH	LINE NO. *	FIGURE NO.	TABLE NO.	RECOMMENDED CHANGES AND REASON <i>(Provide exact wording of recommended changes, if possible).</i>
----------	----------	------------	------------	------------	-----------	---

--	--	--	--	--	--	--

**Reference to line numbers within the paragraph or subparagraph.*

TYPED NAME, GRADE OR TITLE	TELEPHONE EXCHANGE/AUTOVON, PLUS EXTENSION	SIGNATURE
----------------------------	--	-----------

TO: <i>(Forward direct to addressee listed in publication)</i> AMSTALC-LMIT / TECH PUBS, TACOM-RI 1 Rock Island Arsenal Rock Island, IL 61299-7630	FROM: <i>(Activity and location) (Include ZIP Code)</i>	DATE
--	--	-------------

PART II – REPAIR PARTS AND SPECIAL TOOL LISTS AND SUPPLY CATALOGS/SUPPLY MANUALS

PUBLICATION NUMBER TM 9-2320-312-10	DATE 17 December 2003	TITLE M878A2 Truck, Tractor, Yard Type
---	---------------------------------	--

PAGE NO.	COLM NO.	LINE NO.	NATIONAL STOCK NUMBER	REFERENCE NO.	FIGURE NO.	ITEM NO.	TOTAL NO. OF MAJOR ITEMS SUPPORTED	RECOMMENDED ACTION

PART III – REMARKS *(Any general remarks or recommendations, or suggestions for improvement of publications and blank forms. Additional blank sheets may be used if more space is needed.)*

TYPED NAME, GRADE OR TITLE	TELEPHONE EXCHANGE/AUTOVON, PLUS EXTENSION	SIGNATURE
----------------------------	--	-----------

THE METRIC SYSTEM AND EQUIVALENTS

<p>Linear Measure</p> <p>1 Centimeter = 10 Millimeters = 0.01 Meters = 0.3937 Inches 1 Meter = 100 Centimeters = 1000 Millimeters = 39.37 Inches 1 Kilometer = 1000 Meters = 0.621 Miles</p> <p>Weights</p> <p>1 Gram = 0.001 Kilograms = 1000 Milligrams = 0.035 Ounces 1 Kilogram = 1000 Grams = 2.2 Pounds 1 Metric Ton = 1000 Kilograms = 1 Megagram = 1.1 Short Tons</p> <p>Liquid Measure</p> <p>1 Milliliter = 0.001 Liters = 0.0338 Fluid Ounces 1 Liter = 1000 Milliliters = 33.82 Fluid Ounces</p>	<p>Square Measure</p> <p>1 Sq Centimeter = 100 Sq Millimeters = 0.155 Sq Inches 1 Sq Meter = 10,000 Sq Centimeters = 10.76 Sq Feet 1 Sq Kilometer = 1,000,000 Sq Meters = 0.386 Sq Miles</p> <p>Cubic Measure</p> <p>1 Cu Centimeter = 1,000 Cu Millimeters = 0.06 Cu Inches 1 Cu Meter = 1,000,000 Cu Centimeters = 35.31 Cu Feet</p> <p>Temperature</p> <p>$5/9 (^{\circ}\text{F} - 32) = ^{\circ}\text{C}$ 212° Fahrenheit is equivalent to 100° Celsius 90° Fahrenheit is equivalent to 32.2° Celsius 32° Fahrenheit is equivalent to 0° Celsius $9/5 \text{ C}^{\circ} + 32 = \text{F}^{\circ}$</p>
--	--

APPROXIMATE CONVERSION FACTORS

To Change	To	Multiply By
Inches	Centimeters	2.540
Feet	Meters	0.305
Yards	Meters	0.914
Miles	Kilometers	1.609
Sq Inches	Sq Centimeters	6.451
Sq Feet	Sq Meters	0.093
Sq Yards	Sq Meters	0.836
Sq Miles	Sq Kilometers	2.590
Acres	Sq Hectometers	0.405
Cubic Feet	Cubic Meters	0.028
Cubic Yards	Cubic Meters	0.765
Fluid Ounces	Milliliters	29.573
Pints	Liters	0.473
Quarts	Liters	0.946
Gallons	Liters	3.785
Ounces	Grams	28.349
Pounds	Kilograms	0.454
Short Tons	Metric Tons	0.907
Pound-Feet	Newton-Meters	1.356
Pounds per Sq Inch	Kilopascals	6.895
Miles per Gallon	Kilometers per Liter	0.425
Miles per Hour	Kilometers per Hour	1.609

To Change	To	Multiply By
Centimeters	Inches	0.394
Meters	Feet	3.280
Meters	Yards	1.094
Kilometers	Miles	0.621
Sq Centimeters	Sq Inches	0.155
Sq Meters	Sq Feet	10.764
Sq Meters	Sq Yards	1.196
Sq Kilometers	Sq Miles	0.386
Sq Hectometers	Acres	2.471
Cubic Meters	Cubic Feet	35.315
Cubic Meters	Cubic Yards	1.308
Milliliters	Fluid Ounces	0.034
Liters	Pints	2.113
Liters	Quarts	1.057
Liters	Gallons	0.264
Grams	Ounces	0.035
Kilograms	Pounds	2.205
Metric Tons	Short Tons	1.102
Newton-Meters	Pound-Feet	0.738
Kilopascals	Pounds per Sq Inch	0.145
Kilometers per Liter	Miles per Gallon	2.354
Kilometers per Hour	Miles per Hour	0.621

